

E60 Central Information Display CID

Installation location

The Central Information Display is set in the middle of the dashboard. The installed position is at the ideal height relative to the instrument cluster. This arrangement means that drivers can keep the traffic in peripheral view even when their attention is directed toward the CID.

Construction

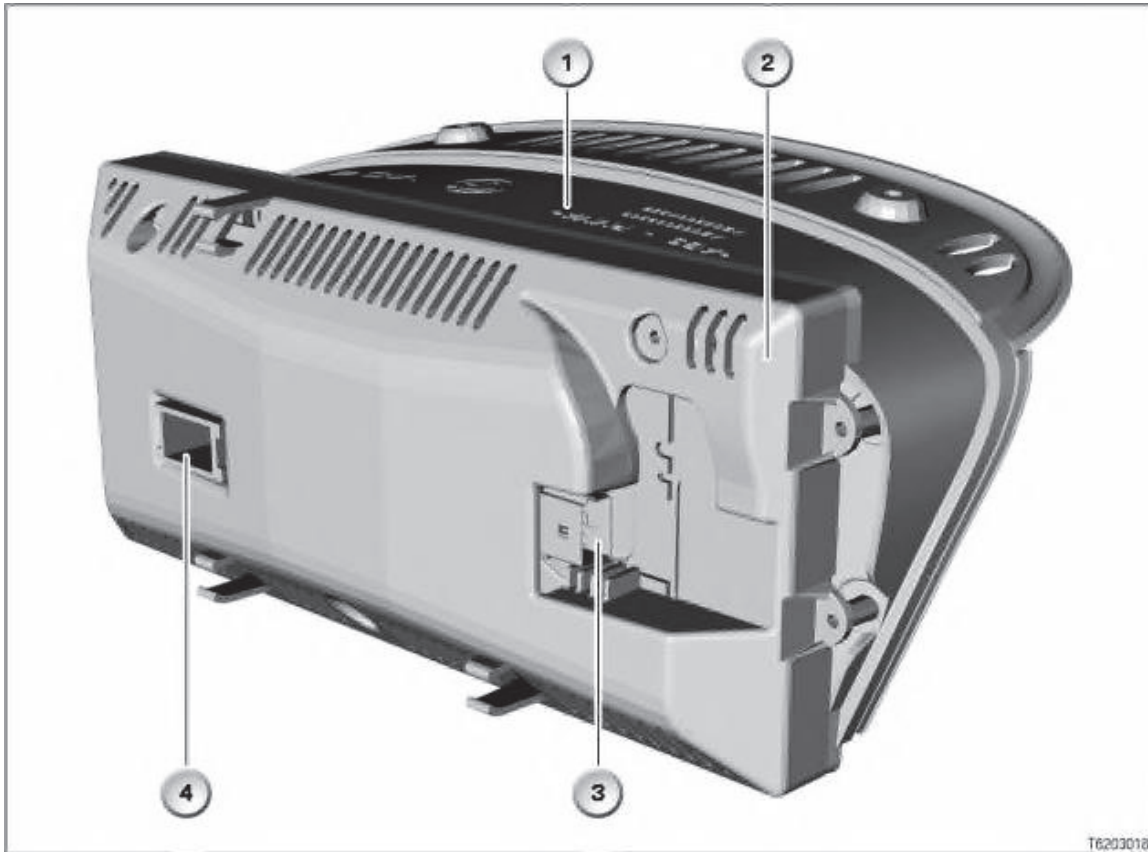

Index	Explanation	Index	Explanation
1	Front housing with glass cover	2	Rear housing with integrated electronics and liquid-crystal display
3	Connector for the LVDS data line	4	Connector for the onboard power supply

The Central Information Display consists of

- front housing with glass cover
- liquid-crystal display
- rear housing with integrated electronics

The CID has a phototransistor for brightness control of the LCD (dependent on ambient luminosity). The LCD is heated.

The Central Information Display is connected to by an LVDS data line (Low Voltage Differential Signaling) to the Multi-audio system controller M-ASK or to the Car Communication Computer CCC, as applicable. The LVDS data line technology can reliably transmit graphical data over lengthy distances. Special connectors were developed for the LVDS data line.

The M-ASK or the CCC generates the data for graphical output on the Central Information Display.

Note: Availability of the CCC

The CCC will not be available until a later juncture.
 The M-ASK and the CCC are described in a separate BMW Service Technology publication.

Pin assignment X13822, 12-pin (black)

Pin	Type	Explanation
1	V	Power supply with terminal 30g (switched)
2	---	---
3	M	Terminal 31, earth
4	---	---
5	E/A	K-CAN High
6	E/A	K-CAN Low
7	---	---
8	---	---
9	---	---
10	---	---
11	---	---
12	---	---
		E/A = Input and output M = Ground V = Supply For current specifications regarding pin assignment, please refer to BMW diagnosis system

Pin assignment X13823, 10-pin (black)

Pin	Type	Explanation
1	E	LVDS channel 2 (positive)
2	E	LVDS channel 2 (negative)
3	---	---
4	E	LVDS channel 1 (positive)
5	E	LVDS channel 1 (negative)
6	E	LVDS clock (positive)
7	E	LVDS clock (negative)
8	---	---
9	E	LVDS channel 0 (positive)
10	E	LVDS channel 0 (negative)
		E = Input For current specifications regarding pin assignment, please refer to BMW diagnosis system

How it works

As in the E65, the CID is a display with what is known as a "transflective" surface.

Transflective is a word formed by combining the words "transmissive" and "reflective". The surface reflects daylight shining on it: this ambient light makes other displays unreadable. The reflected daylight is used to increase the luminosity of the display. The display becomes brighter.

When ambient light levels are low and in the dark, the readability of the display is ensured by the transmissive background lighting.

The display is also heated. This ensures that it reaches its optimum operating temperature quickly at low ambient temperatures and improves readability.

The CID has an integral phototransistor for controlling the brightness of the display. In order to control brightness correctly, the CID evaluates the following signals:

- Dimmer signal from the light module (dimmer setting) via the K-CAN
- Signal from the central photocell in the instrument cluster via the K-CAN

A new feature of the E60 is that the display brightness (offset of brightness) can be adjusted.

Precondition: The control setting for the phototransistor is between 1 % and 50 %. When the control setting of the phototransistor is above approximately 50 %, the phototransistor alone controls the brightness of the display.

In order to adjust the brightness of the CID, you have to open the "Settings" menu, select "Display settings" and then select the "Control Display" option.

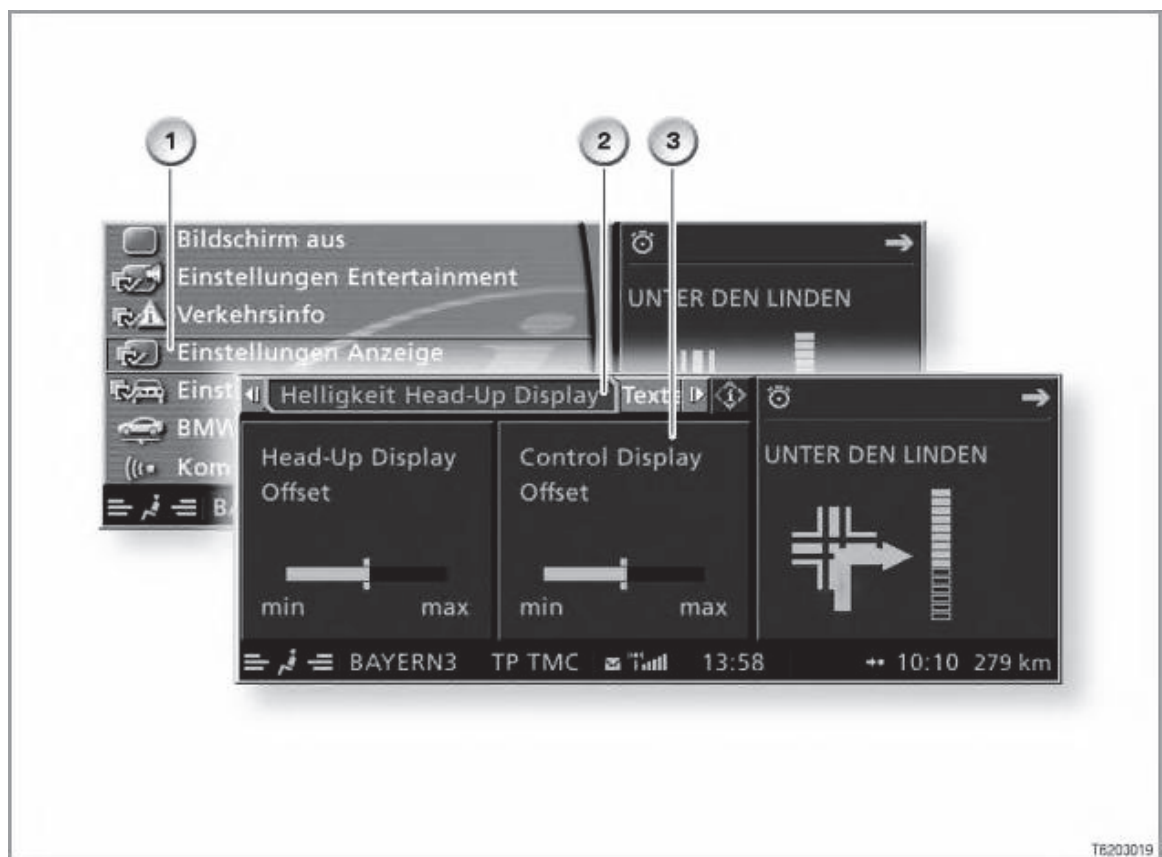

Index	Explanation	Index	Explanation
1	Display settings	2	Brightness of the Head-Up Display (as of 09/2003)
3	Brightness of the Control Display (= Central Information Display)	Offset	Deviation of brightness from middle position

Note: The value for display brightness is one of the personalised settings stored in the remote control.

The preset for brightness offset is stored in the memory chip of the remote control.

The setting (brightness offset) is transmitted by the remote control currently in use to the data memory of the CID.