

11194 BMW 535i AND 535xi AWD SERIES SPORT WAGON

11/30/2012

GROSS LOAD CAPACITY WHEN USED AS A WEIGHT CARRYING HITCH: 2,000 LBS. TRAILER WEIGHT & 200 LBS. TONGUE WEIGHT.

*****DO NOT EXCEED VEHICLE MANUFACTURER'S RECOMMENDED TOWING CAPACITY.*****

WARNING: ALL NON-TRAILER LOADS APPLIED TO THIS PRODUCT MUST BE SUPPORTED BY AUXILIARY STABILIZING STRAPS.

**** FAILURE TO PROPERLY SUPPORT NON-TRAILER LOADS WILL VOID PRODUCT WARRANTY****

HAVING INSTALLATION QUESTIONS? CALL TECHNICAL SUPPORT AT 1-800-798-0813

Parts List			
ITEM	QTY	PART NUMBER	DESCRIPTION
1	6	M10 - 1.5 x 35mm	HEX TAP BOLT
2	6	3/8"	CONICAL TOOTHED WASHER
3	4	3/8"	WASHER
4	6	3/8-16 x 1 1/4 LG.	CARRIAGE BOLT
5	6	HFN3816	HEX FLANGE NUT
6	2	7/16-14 x 1	CARRIAGE BOLT
7	2	7/16-14	HEX FLANGE NUT

RUBBER ISOLATOR REMOVAL DIAGRAM

This technique can be used if and Exhaust Hanger Removal Pliers is not available.

Using a 5/8" open end wrench, slide the wrench up to the rubber isolator, cradling the hanger rod as shown. Next place the flat edge of a pry bar between the wrench and the hanger stop or hanger rod. Then simply rotate the pry bar toward the wrench to remove the rubber isolator.

Note: Using a spray lubricant or soapy water on the hanger rod and the rubber isolator helps removal.

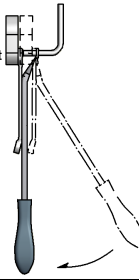

TOOLS REQUIRED

SOCKET WRENCH
TORQUE WRENCH
8, 10, 16 AND 17mm SOCKET
5/8 in, 9/16 in SOCKET
8 in RATCHET EXTENSION
UNIVERSAL JOINT
FLATHEAD SCREWDRIVER

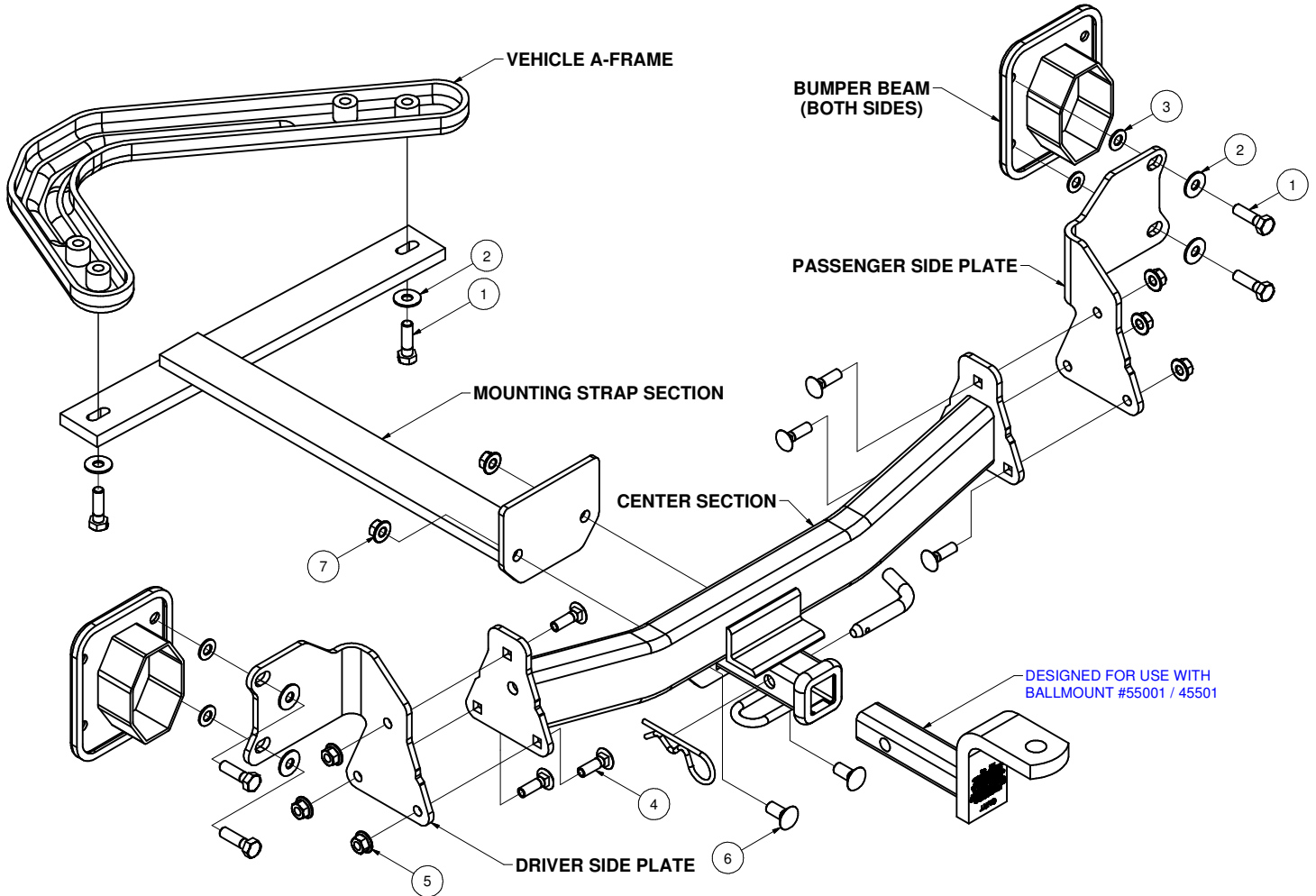

DESIGNED FOR USE WITH BALLMOUNT #55001 / 45501

HITCH WEIGHT: 36.5 LBS.

INSTALL TIME

PROFESSIONAL: 60 MINUTES
NOVICE (DIY): 120 MINUTES

INSTALL NOTES:

- NO DRILLING REQUIRED
- LOWER EXHAUST

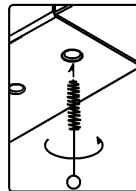

WELDNUT CLEANING

To remove debris from weldnuts in frame, spray lubricant or compressed air into hole. For heavy debris, use a small wire brush. (Be careful not to damage threads).

FRONT
↑
REAR

PERIODICALLY CHECK THIS RECEIVER HITCH TO ENSURE THAT ALL FASTENERS ARE TIGHT AND THAT ALL STRUCTURAL COMPONENTS ARE SOUND.

Curt Manufacturing Inc., warrants this product to be free of defects in material and/or workmanship at the time of retail purchase by the original purchaser. If the product is found to be defective, Curt Manufacturing Inc., may repair or replace the product, at their option, when the product is returned, prepaid, with proof of purchase. Alteration to, misuse of, or improper installation of this product voids the warranty. Curt Manufacturing Inc.'s liability is limited to repair or replacement of products found to be defective, and specifically excludes liability for incidental or consequential loss or damage.

11194 BMW 535i AND 535xi AWD SERIES SPORT WAGON

11/30/2012

GROSS LOAD CAPACITY WHEN USED AS A WEIGHT CARRYING HITCH: 2,000 LBS. TRAILER WEIGHT & 200 LBS. TONGUE WEIGHT.

*****DO NOT EXCEED VEHICLE MANUFACTURER'S RECOMMENDED TOWING CAPACITY.*****

WARNING: ALL NON-TRAILER LOADS APPLIED TO THIS PRODUCT MUST BE SUPPORTED BY AUXILIARY STABILIZING STRAPS.

**** FAILURE TO PROPERLY SUPPORT NON-TRAILER LOADS WILL VOID PRODUCT WARRANTY****

HAVING INSTALLATION QUESTIONS? CALL TECHNICAL SUPPORT AT 1-800-798-0813

INSTALLATION STEPS

1. Remove bolt that connects rear air dam to the rear passenger side underbody panel. Remove bolt using 8mm socket.
2. Unhook locking tabs at rear of air dam with a flat head screwdriver.
3. Bend air dam down to access (3) nuts. Use a ratchet extension, universal joint, and 10mm socket to remove nuts.
4. Return air dam, bolt from Step 1 and (3) nuts from Step 3 to vehicle owner.
5. Remove rear passenger side underbody panel by removing (3) bolts with 8mm socket. Remove (4) bolts using 10mm socket. This underbody panel and (7) bolts will be reinstalled in Step 16.
6. Lower exhaust for ease of installation by removing (3) rubber isolators. (See RUBBER ISOLATOR REMOVAL DIAGRAM)
7. Remove (2) bolts on inside of driver side bumper beam and (2) bolts on inside of passenger side bumper beam.
8. Remove (2) rear bolts on vehicle A-FRAME.
9. Return bolts from Step 7 and 8 to vehicle owner.
10. Tape (4) 3/8" washers over slots (between bumper beam and plate) on both DRIVERS SIDE PLATE and PASSENGER SIDE PLATE to ease installation.
11. Raise DRIVER SIDE PLATE into position and loosely install with (2) M10 -1.5 bolts and (2) 3/8" conical toothed washers, as shown. Repeat with PASSENGER SIDE PLATE .
12. Raise CENTER SECTION into position between side plates and loosely install (6) 3/8 in. carriage bolts and hex flange nuts, as shown.
13. Raise MOUNTING STRAP SECTION into position and loosely install (2) 7/16 in. carriage bolts and hex flange nuts, as shown.
14. Secure MOUNTING STRAP SECTION to vehicle A-FRAME with (2) M10 -1.5 bolts and (2) 3/8" conical toothed washers, as shown.
15. Torque all 3/8 in. hardware to 45 lb-ft, M10-1.50 hardware to 45 lb-ft, 7/16 in. hardware to 70 lb-ft.
16. Reinstall rear passenger side underbody panel with hardware removed in Step 5.
17. Raise exhaust back into position.

PERIODICALLY CHECK THIS RECEIVER HITCH TO ENSURE THAT ALL FASTENERS ARE TIGHT AND THAT ALL STRUCTURAL COMPONENTS ARE SOUND.

Curt Manufacturing Inc., warrants this product to be free of defects in material and/or workmanship at the time of retail purchase by the original purchaser. If the product is found to be defective, Curt Manufacturing Inc., may repair or replace the product, at their option, when the product is returned, prepaid, with proof of purchase. Alteration to, misuse of, or improper installation of this product voids the warranty. Curt Manufacturing Inc.'s liability is limited to repair or replacement of products found to be defective, and specifically excludes liability for incidental or consequential loss or damage.