

Step 1: Fully slide open the front roof.

Step 2: locate the mechanism parts. We are looking for the Drive Cable Plate, part 9 in the picture. (mechanism parts 4, 5, 6, 7, 8 and 9 activate the rear roof.)

Overview of glass lid mechanism:

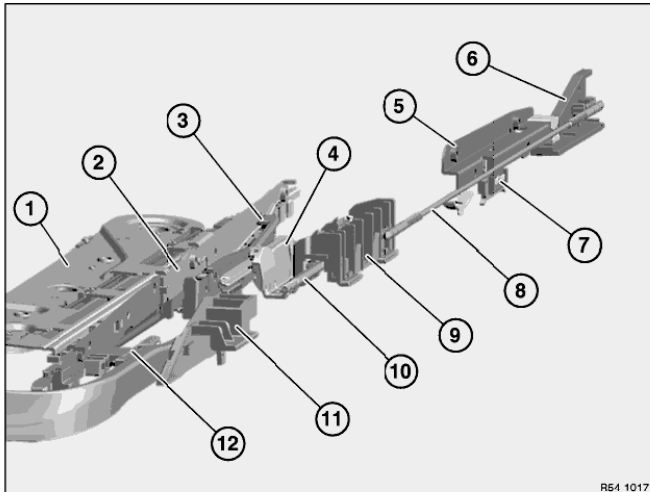

RE4 1017

- | | | | |
|---|----------------------------------|----|------------------------------------------------|
| 1 | Floating roofline mechanism | 7 | Spring retainer |
| 2 | Mechanism, front glass lid | 8 | Drive cable, rear glass lid (connecting link) |
| 3 | Drive wedge | 9 | Drive cable plate |
| 4 | Drive plate | 10 | Drive cable, front glass lid (connecting link) |
| 5 | Mechanism, rear glass lid | 11 | Control carriage, wind deflector |
| 6 | Control carriage, rear glass lid | 12 | Slide element |

Step 3: Remove the guide (part 2 in below picture) and its spring.

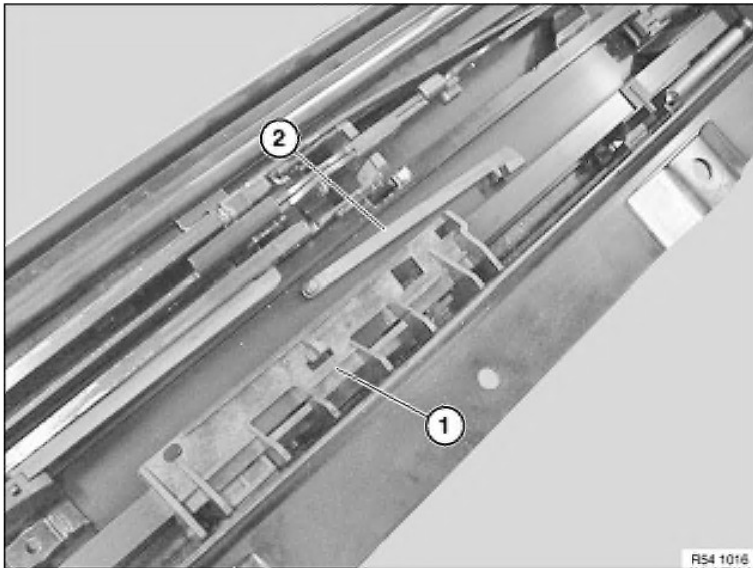

Step 4: Locate the front triangle shaped front of the drive cable plate.

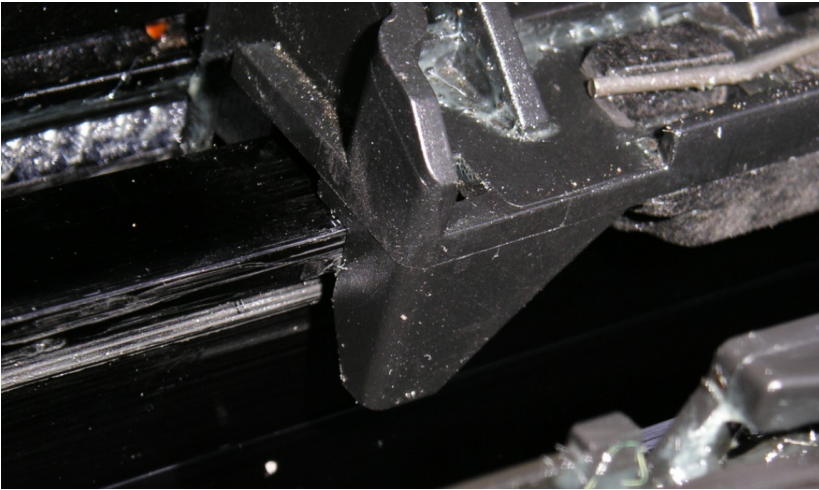

Step 5: Take a Dremel tool (or look-a-like) and cut away the triangle shaped front corner of the drive cable plate.



Step 6: repeat step 3, 4 and 5 for the left side mechanism.

Step 7: Initialize your sunroof:

Put your fob in the slot and turn the car ON (ie don't start it - but push the start button with your foot OFF the break/clutch)

Now, push and HOLD the sunroof button up (vent position). After about 15-20 seconds, the sunroof will vent. CONTINUE HOLDING THE BUTTON UP. After about 15 to 20 seconds (keep holding) , the sunroof will close, the open completely, then close completely.

Once the sunroof has closed completely, the process is over.

It's important that you do not let go of the button during the procedure, otherwise you have to start all over again. Warnings might come up on i-drive or the on-board-computer. That is normal during this initialization.

That's it.