

In my case No software update or coding needed from the BMW dealer for the car: US Spec '08 5 series with CCC Professional Navigation/Factory Ipod(SA 6FL)/No CD Changer /No PDC

BMW ACM Unit:



Side View Camera Power Unit with Switch : Eclipse(Made in Japan)



Side View Camera: Eclipse (Made in Japan)



■ Lateral direction

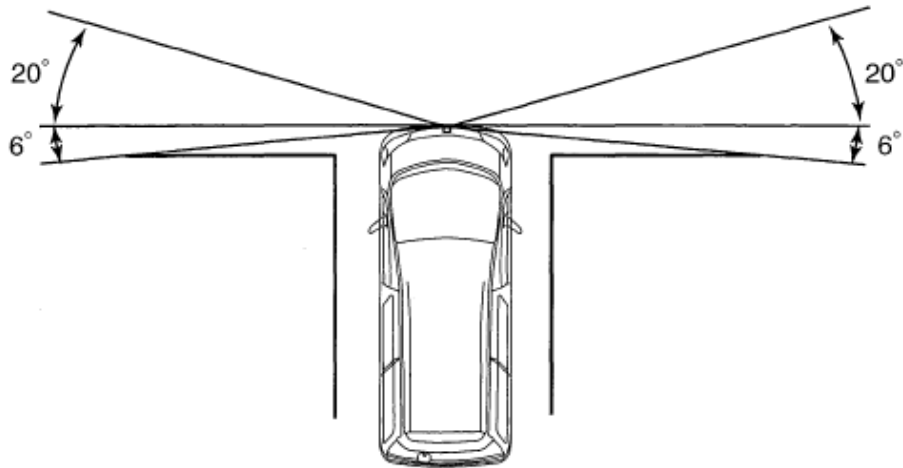

■ Vertical direction

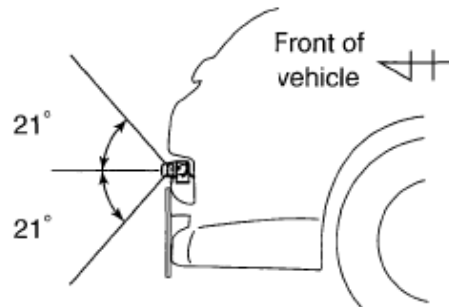

There is a mask in the center of the screen. The area to the right of the mask shows the right side of the vehicle, and the area to the left of the mask shows the left side of the vehicle.

The area around the mask may appear slightly dark depending on the road conditions, but this occurs when the objects on the left and right are optically overlapping on the screen, and is not a sign of a malfunction.

The screen display shown below is an example; the display range will vary depending on factors such as the mounting position, the state of the vehicle and the road conditions.

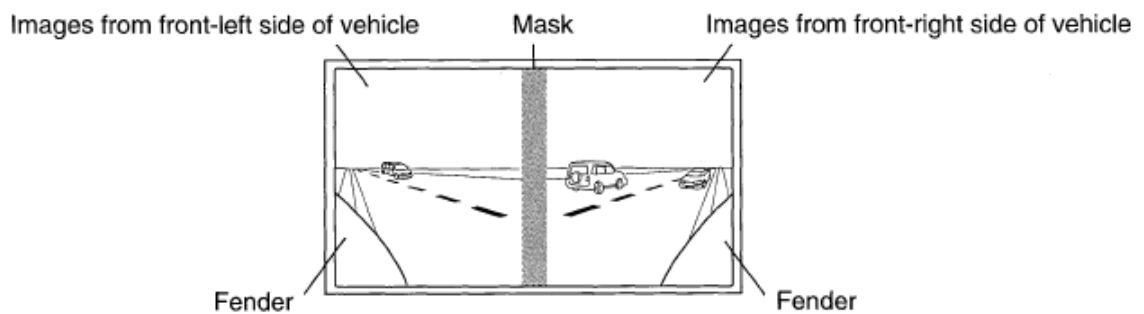

Backup Camera: Panasonic Wide-angle mirror image Color 250 000 pixels CCD Camera (Made in Japan) , Brightness range Approx. 1.5 lux – 100 000 lux works well in low light and very bright conditions



Camera field of view

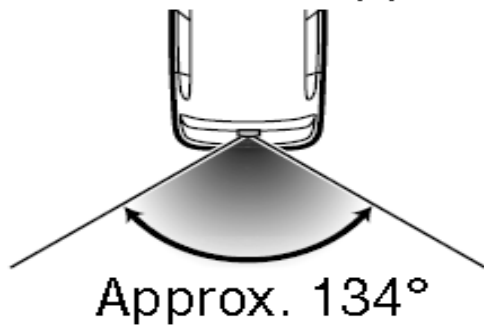
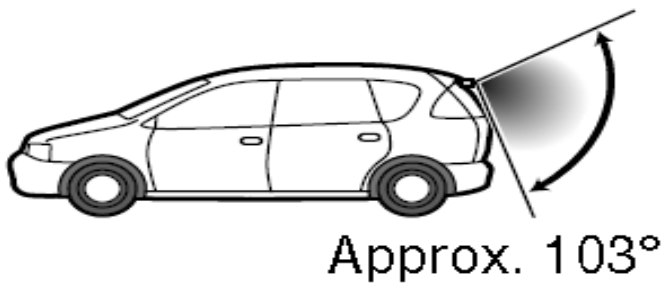

BMW ACM available options after installation:



ACM Service Menu

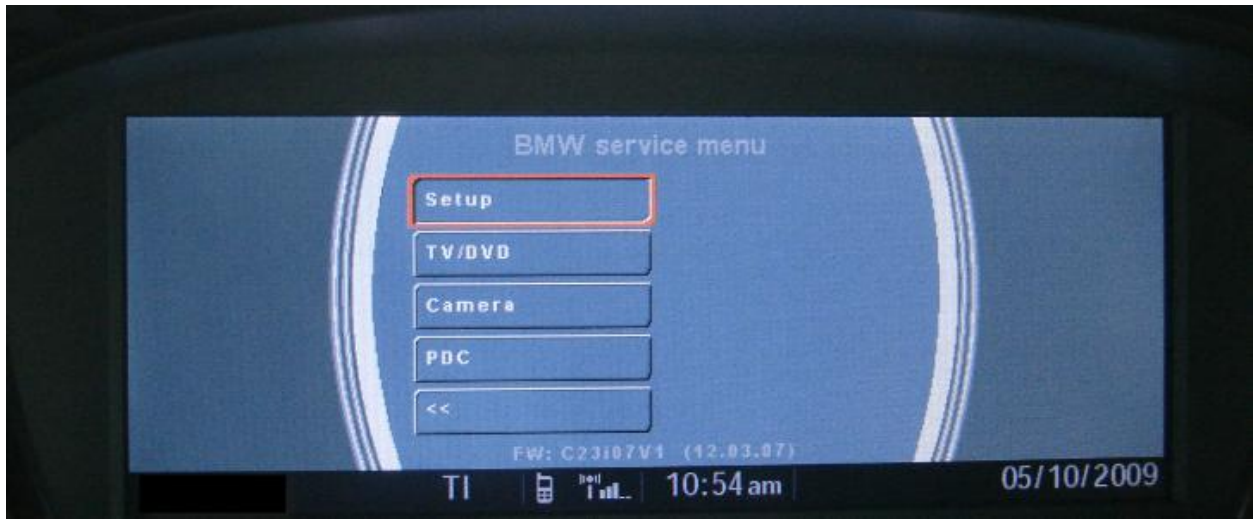

TV option: Turned off

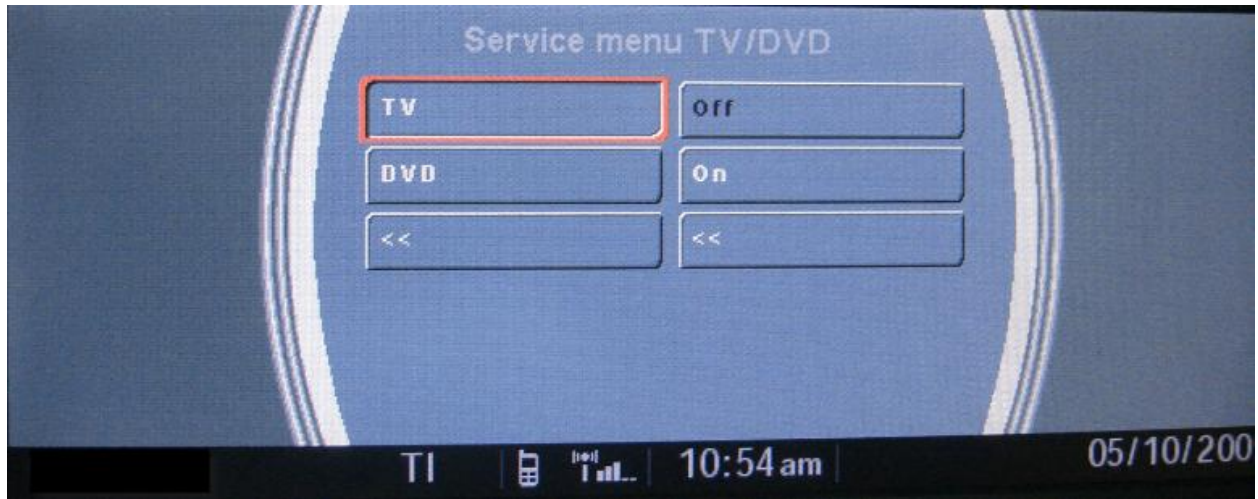

DVD option: Turned Off

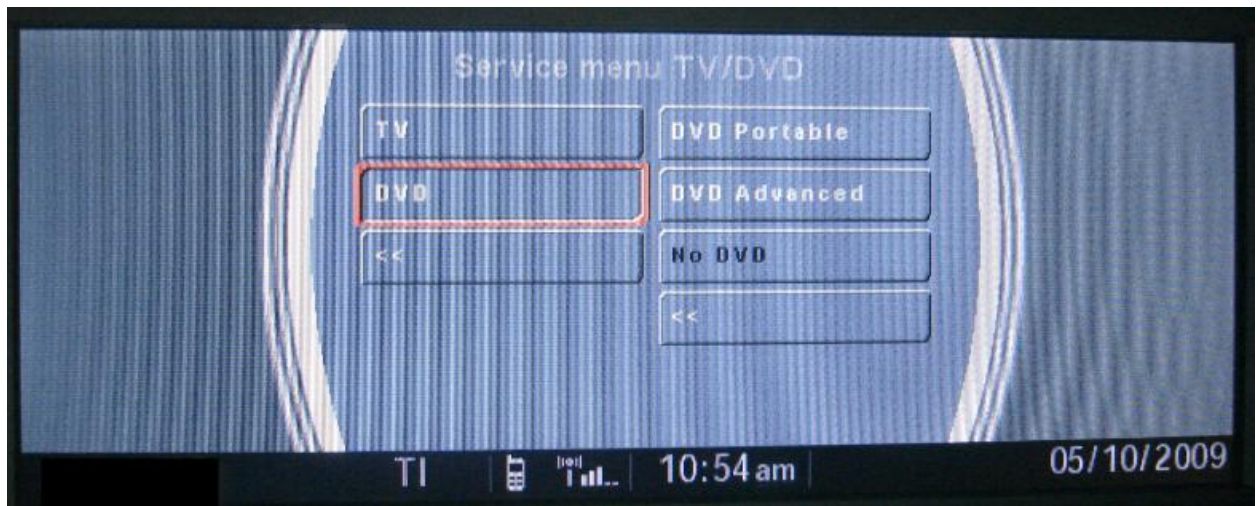

Camera Option: Side View Camera/Rear Camera Turned On



PDC Option: Turned off

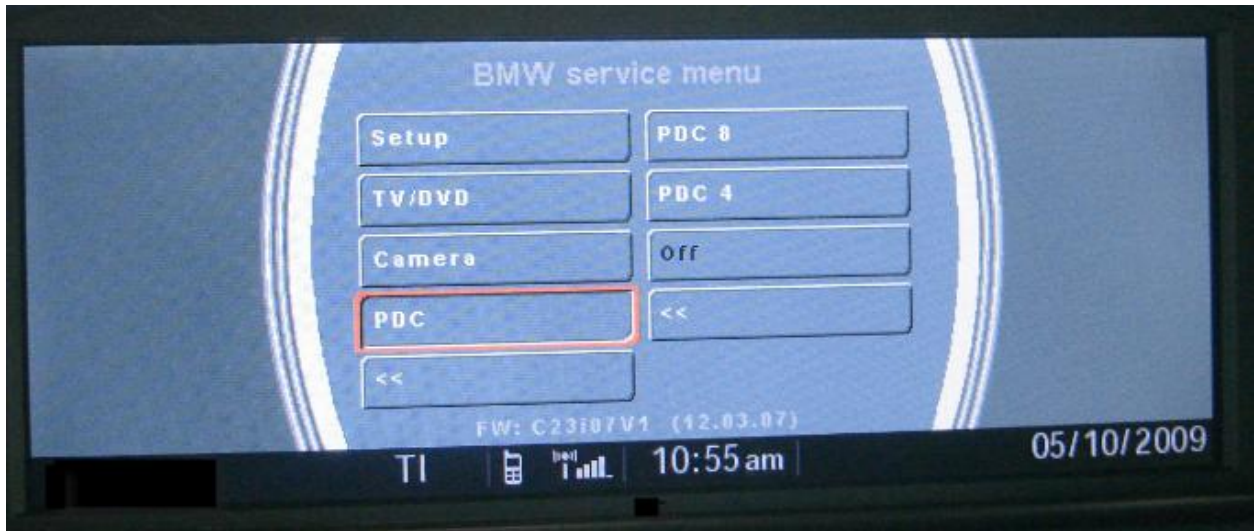

BMW ACM available options after changing setup:



Onboard Info: Battery Voltage, Available Gas in US Gallons, Engine temperature



Location of Side View Camera:



Location of Rear Camera: Very small footprint, the picture is not doing justice.



Rear Camera View: Wide angle Horizontal: 134°, Vertical: 103°, you can even see the sky though the camera is mounted on the license plate, picture taken during cloudy conditions. Picture is very clear when there is sun.

More than 10 feet away from curb, wide angle view you can see the sky and roof of the building the camera is fitted low just above the license plate , excellent view



Less than 1 foot close to curb



Car parked more than 14 feet away, wide angle view to the left and right you can see the sky and roof of the building, excellent view



Less than 1 foot away from the car behind

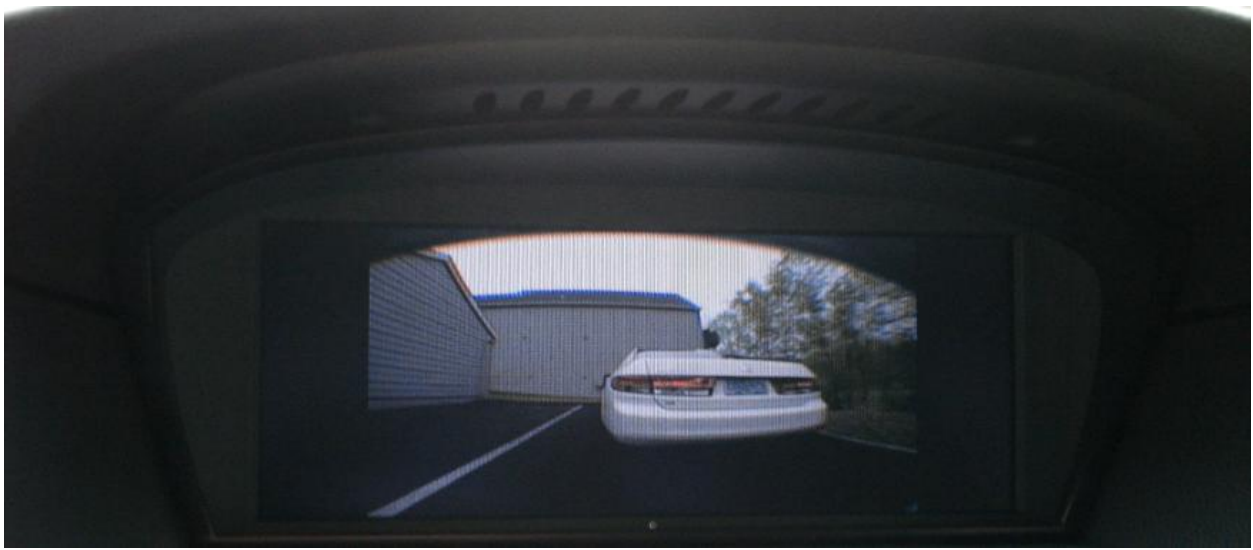

Side View Camera shows cars to the left and right and shows **how close you are parked to the curb**, Side View camera option is on by default in the ACM but has to be operated by a switch since this is after market Eclipse camera, excellent picture quality for this camera also



The above option is useful when you are trying to enter an intersection with view blocked on both left and right side of the car but the front of the car protruding onto the road.

