

65 83 010 Removing and installing/replacing Car Communication Computer

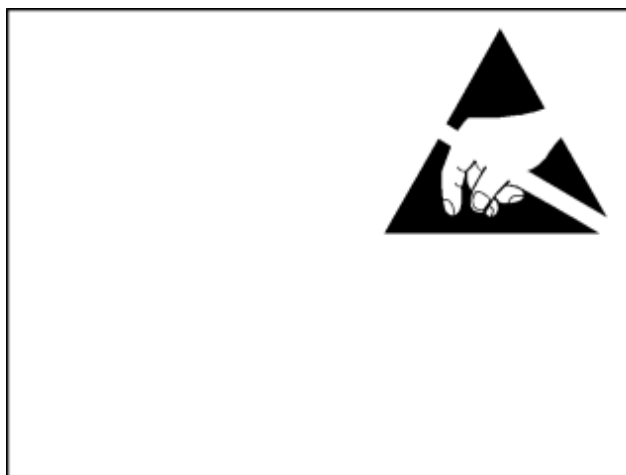

Important!

Read and comply with notes on [protection against electrostatic damage \(ESD protection\)](#).



Necessary preliminary tasks:

- Remove [luggage compartment trim on side panel on right](#)
- Disconnect [battery negative lead](#)
- Remove [middle trim for instrument panel](#)

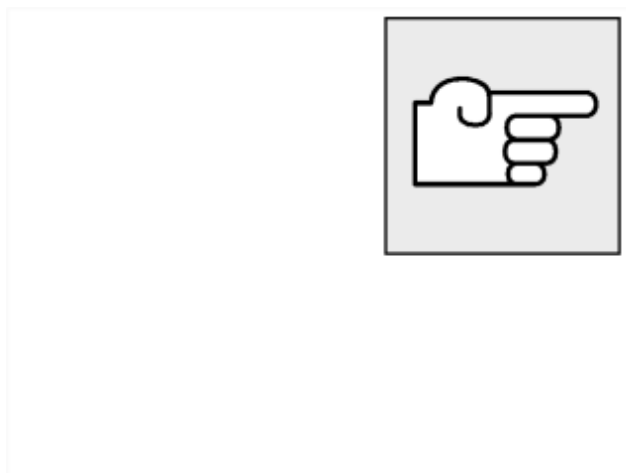

Note:

Comply with notes and instructions on [handling optical waveguides](#).

Release screws (1).

Important!

Do not scratch center console trim, cover if necessary.

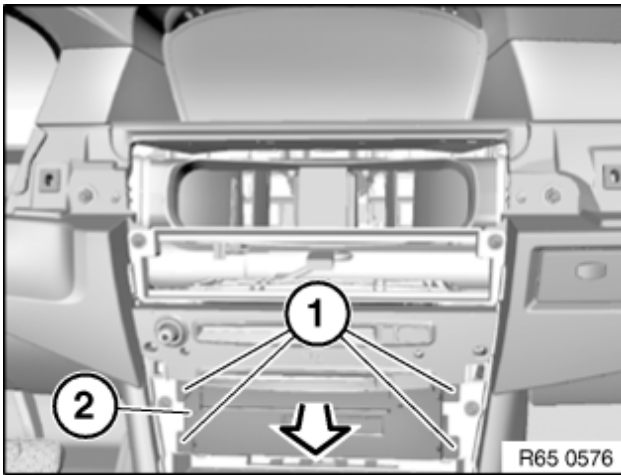

Pull back Car Communication Computer (2) slightly.

Unlock associated plug connections and disconnect.

Remove Car Communication Computer (2).

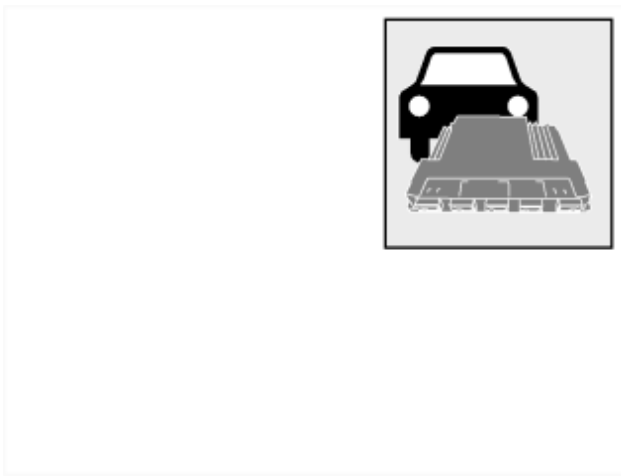

Replacement:

Carry out [programming/coding](#).