



# Parts and Accessories. Installation Instructions.

## Auxiliary Connector Retrofit for External Audio Sources

**BMW 3 Series (E46),  
BMW 5 Series (E39) from 09/02,  
BMW X5 (E53) from 10/02,  
BMW X3 (E83),  
BMW Z4 (E85)**

**These installation instructions are only valid for cars with SA 602/609/662/661+650 from 09/02**

**Retrofit kit No.:**           65 12 0 153 501  
                                  65 12 0 153 502  
                                  65 12 0 153 503

### Installation time

The installation time is 1.5 hours, but this may vary depending on the condition of the car and the equipment in it.

### Important information

These installation instructions are primarily designed for use within the BMW dealership organisation and by authorised BMW service companies.

In any event the target group for these installation instructions is specialist personnel trained on BMW cars with the appropriate specialist knowledge.

All work must be completed using the latest BMW repair manuals, circuit diagrams, servicing manuals and work instructions in a rational order using the prescribed tools (special tools) and observing current health and safety regulations.

Ensure that the cables/lines are not kinked or damaged as you install them in the car. The costs incurred as a result of this will not be reimbursed by BMW AG.

Additional cables/lines that you install must be secured with cable ties.

If the specified PIN chambers are occupied, bridges, double crimps or twin-lead terminals must be used.

All the figures show LHD cars, proceed accordingly on RHD cars.

Pictograms:



denotes instructions that draw your attention to special features.

◀ denotes the end of the instruction or caution text.

See the EBA CD or After Sales Assistance Portal for explanations of the pictograms.

Do not archive the hard copy of these installation instructions since daily updates are made by Aftersales Assistance Portal.

Subject to technical modifications.

### **List of special equipment**

The following special equipment must be taken into consideration when installing the retrofit kit. The various sections contain corresponding information.

- SA 602**            On-board monitor
- SA 609**            Navigation system
- SA 661+650**    BMW Business radio with CD drive
- SA 662**            BMW Business CD radio

### **Special tools required**

E46 installation wedge (00 9 321)

E39 radio puller (65 1 100)

Special E46 radio tool (65 1 110) for SA 602 only

## Contents

Section	Page
1. Parts list .....	4
2. Preparations.....	5
3. Connection diagram.....	6
4. To install and connect the AUX connector wiring harness in E46 cars .....	7
5. To install and connect the AUX connector wiring harness in E39 cars .....	9
6. To install and connect the AUX connector wiring harness in E53 cars .....	10
7. To install and connect the AUX connector wiring harness in E83 cars .....	11
8. To install and connect the AUX connector wiring harness in E85 cars .....	12
9. Concluding work and coding .....	13
10. Circuit diagram .....	14

## 1. Parts list

### E46 with SA 661+650 only

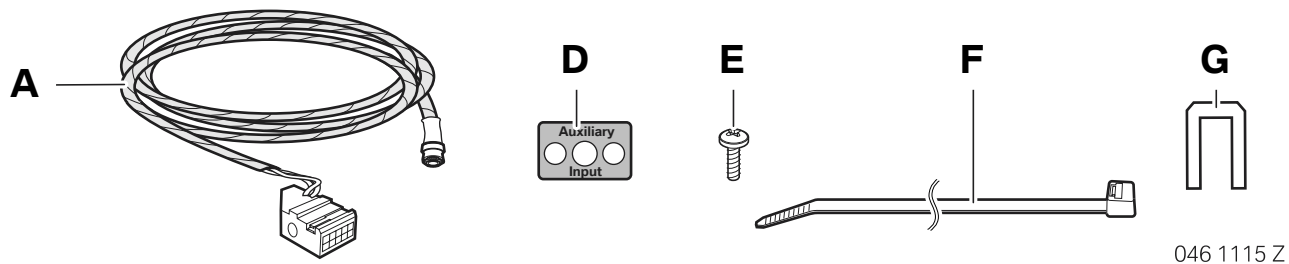

### E39/E53 with SA 661+650 and E83/E85 with SA 662 only

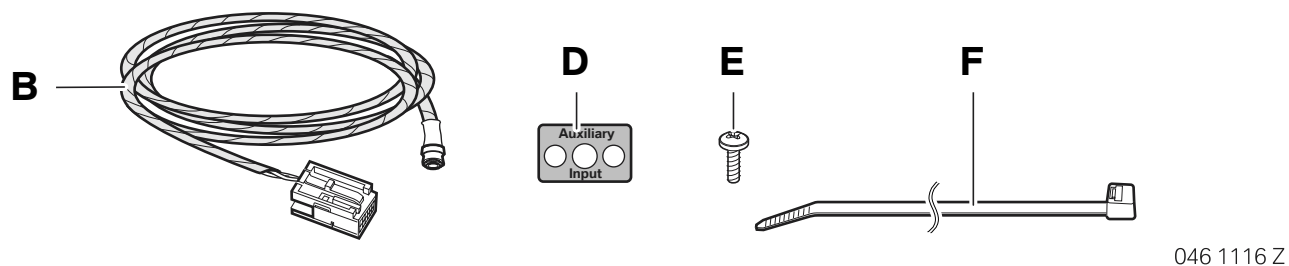

### E39/E46/E53 with SA 602/609 only

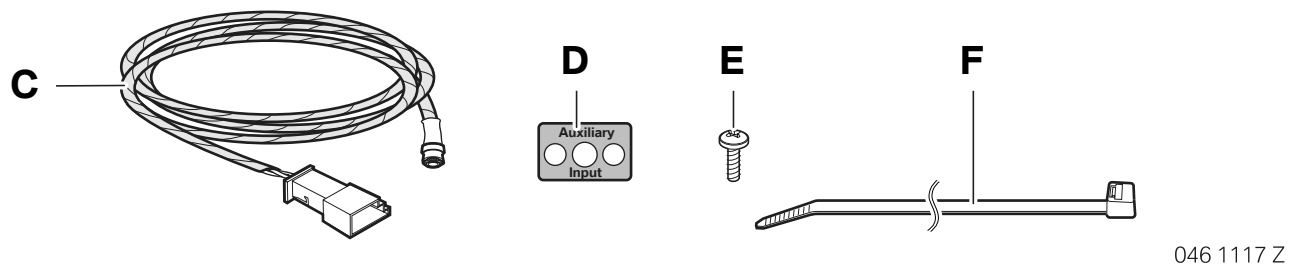

## Legend

- A E46 AUX connector wiring harness with SA 661+650
- B E39/E53 AUX connector wiring harness with SA 661+650 and E83/E85 with SA 662 only
- C E46/E39/E53 AUX connector wiring harness with SA 602/609
- D Mounting plate
- E Philips screw (2x)
- F Cable tie (5x)
- G Locking bar (E46 with SA 661+650 only)

## 2. Preparations

	TIS No.
Conduct a brief test	---
Disconnect the negative pole of the battery	12 00 ...
<b>The following components must be removed first of all:</b>	
Glove box on the right	51 16 360
Radio receiver (cars with SA 662, SA 661+650 only)	65 11 030
Multi Information Display (E39/E53 cars with SA 661+650 only)	65 81 010
On-board monitor (cars with SA 602/609 only)	65 52 013

### 3. Connection diagram

#### E46 with SA 661+650 only

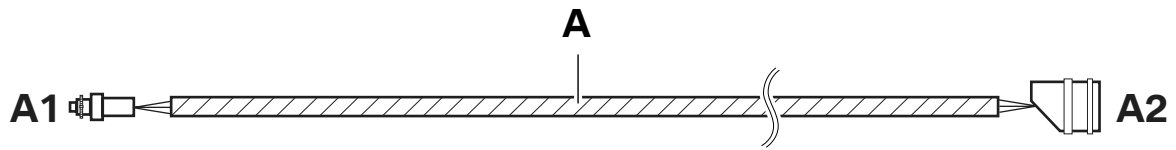

046 1118 Z

Item	Description	Signal	Cable colour / Cross-section	Connection location in the car	Abbreviation / Slot
A	AUX connector wiring harness	---	---	<b>E46 with SA 661+650 only</b>	---
A1	Pawl socket 3.5 mm	---	---	In glove compartment	---
A2	Green 10-pin socket casing	---	---	On radio plug <b>X18126</b>	X18805

#### E39/E53 with SA 661+650 and E83/E85 with SA 662 only

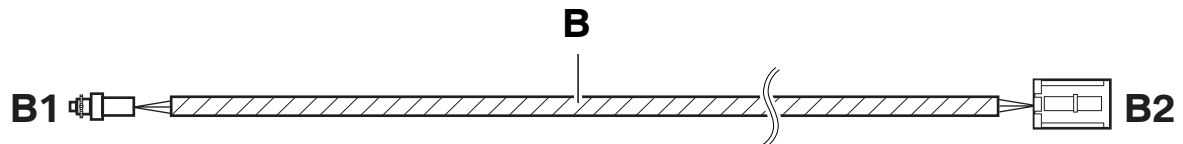

046 1119 Z

Item	Description	Signal	Cable colour / Cross-section	Connection location in the car	Abbreviation / Slot
B	AUX connector wiring harness	---	---	---	---
B1	Pawl socket 3.5 mm	---	---	In glove compartment	---
B2	Black 12-pin socket casing	---	---	<b>E39/E53 with SA 661+650 only</b> and <b>E85 with SA 662</b> On radio plug <b>X18126</b>	X13598
B2	Black 12-pin socket casing	---	---	<b>E83 with SA 662 only</b> On radio plug <b>X13646</b>	X13649

#### E39/E46/E53 with SA 602/609 only

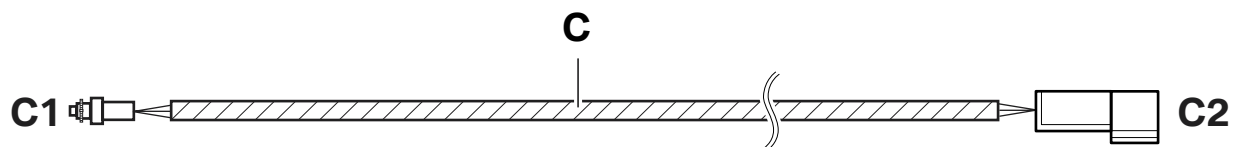

046 1120 Z

Item	Description	Signal	Cable colour / Cross-section	Connection location in the car	Abbreviation / Slot
C	AUX connector wiring harness	---	---	<b>E39/E46/E53 with SA 602/609 only</b>	---
C1	Pawl socket 3.5 mm	---	---	In glove compartment	---
C2	Black 3-pin plug casing	---	---	On plug <b>X14118</b>	X14118

#### 4. To install and connect the AUX connector wiring harness in E46 cars

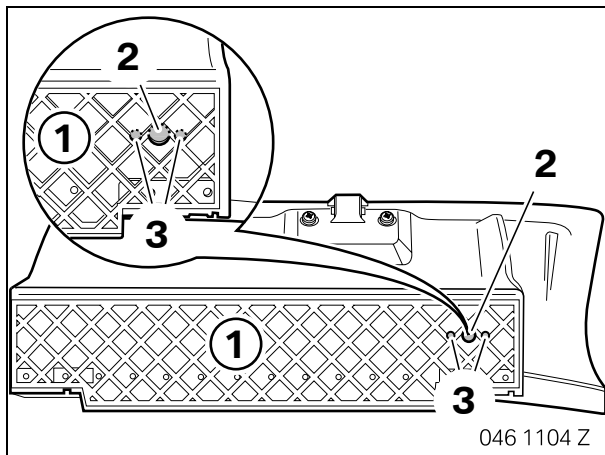

 All holes must be drilled precisely as shown in the illustration. ◀

Drill a hole (2) in the rear of the glove compartment (1) with an 8 mm twist drill bit.

Drill the holes (3) using a 3 mm twist drill bit.

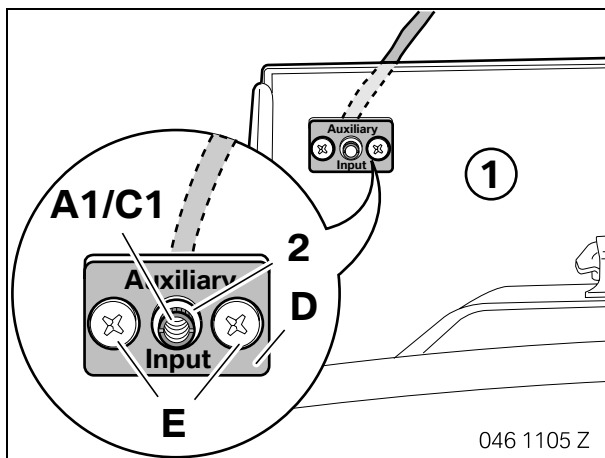

Insert branch **A1/C1** in the glove compartment (1) and secure it to mounting plate **D** with a knurled nut (2).

Secure mounting plate **D** to the glove compartment (1) using Philips screws **E**.

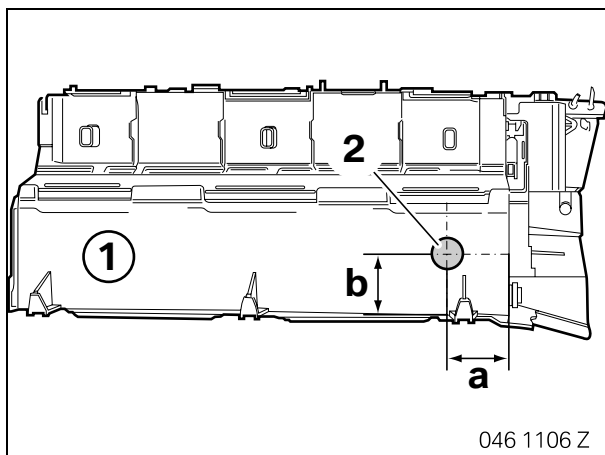

Drill a hole (2) in the trim (1) with a 3 mm twist drill bit through which you can thread the AUX connector wiring harness.

Dimension **a** 40 mm

Dimension **b** 45 mm

Enlarge the hole (2) to a diameter of 20 mm.

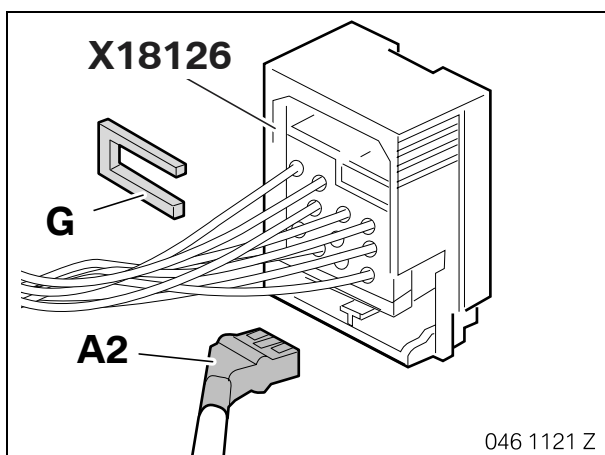

**Cars with SA 661+650 only**

Connect branch **A2** to plug **X18126** and secure it with the locking bar **G**.

4. To install and connect the AUX connector wiring harness in E46 cars

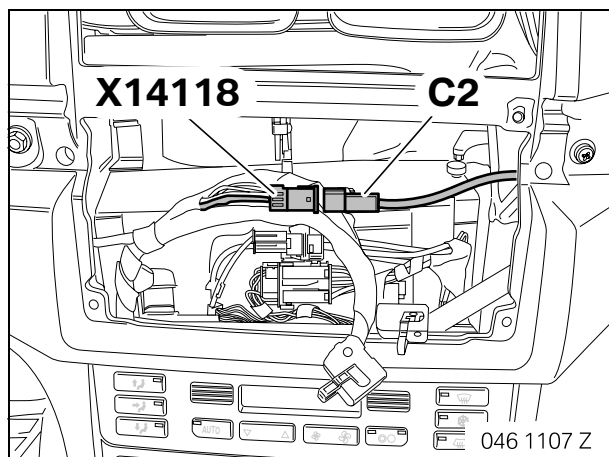

**Cars with SA 602/609 only**

Connect branch **C2** to tied back plug **X14118**.



## 5. To install and connect the AUX connector wiring harness in E39 cars

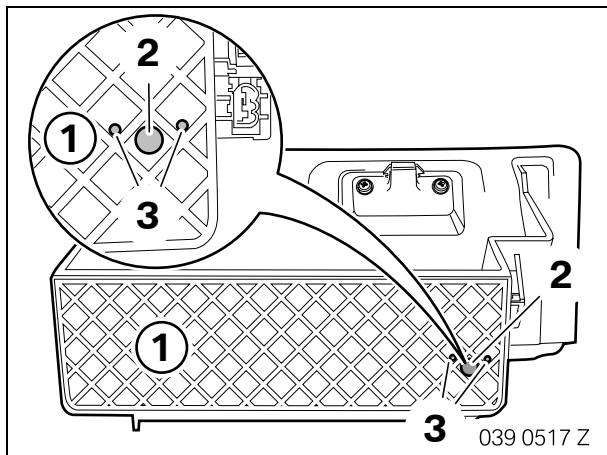

☐ All holes must be drilled precisely as shown in the illustration. ◀

Drill a hole (2) in the rear of the glove compartment (1) with an 8 mm twist drill bit.

Drill the holes (3) using a 3 mm twist drill bit.

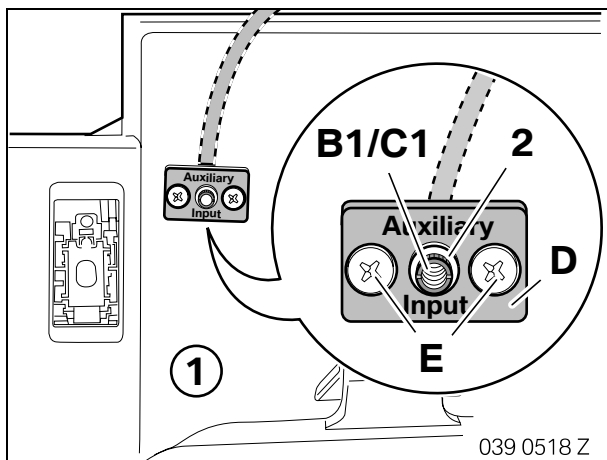

Insert branch **B1/C1** in the glove compartment (1) and secure it to mounting plate **D** with a knurled nut (2).

Secure mounting plate **D** to the glove compartment (1) using Philips screws **E**.

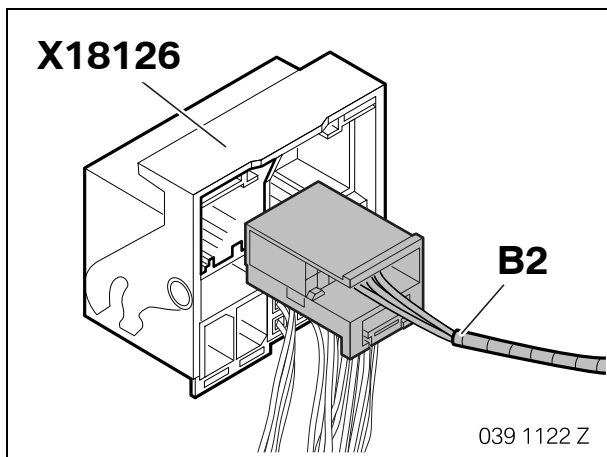

### Cars with SA 661+650 only

Connect branch **B2** to plug **X18126**.

☐ If plug **X13321** is already in the car, the cables from branch **B2** must be disconnected and connected to the same pins in the plug in the car **X13321**. ◀

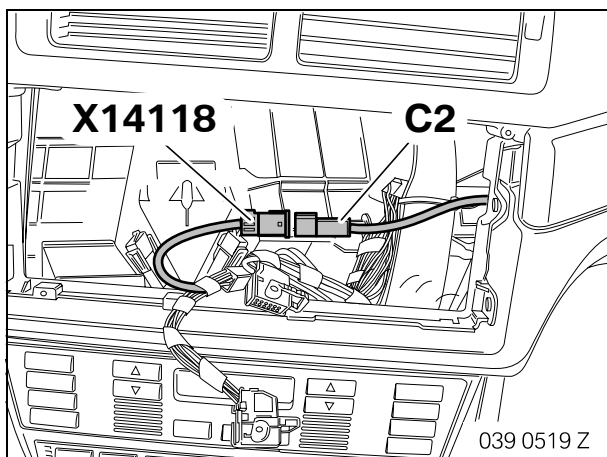

### Cars with SA 602/609 only

Connect branch **C2** to tied back plug **X14118**.

## 6. To install and connect the AUX connector wiring harness in E53 cars

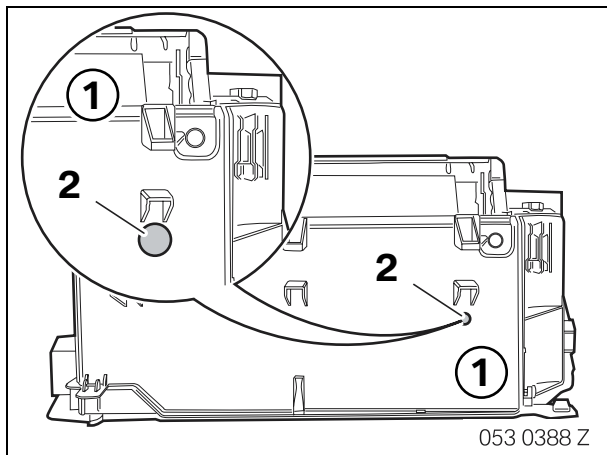

▶ All holes must be drilled precisely as shown in the illustration. ◀

Drill a hole (2) in the trim (1) through the rear of the glove compartment with an 8 mm twist drill bit.

Open the glove compartment and enlarge the hole (2) to a diameter of 20 mm.

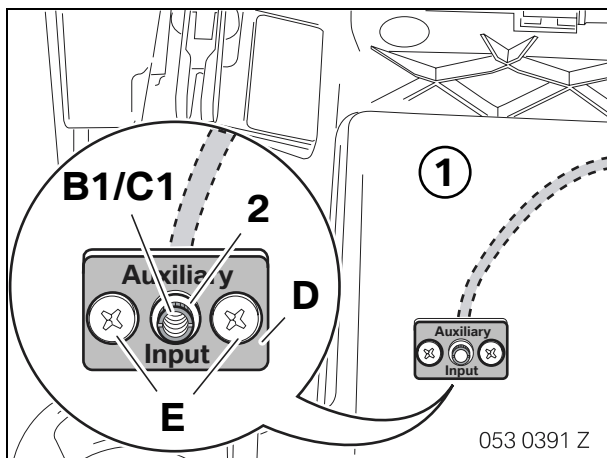

Insert branch **B1/C1** in the glove compartment (1) and secure it to mounting plate **D** with a knurled nut (2).

Mark the mounting holes and drill them with a 3 mm twist drill bit.

Secure mounting plate **D** to the glove compartment (1) using Philips screws **E**.

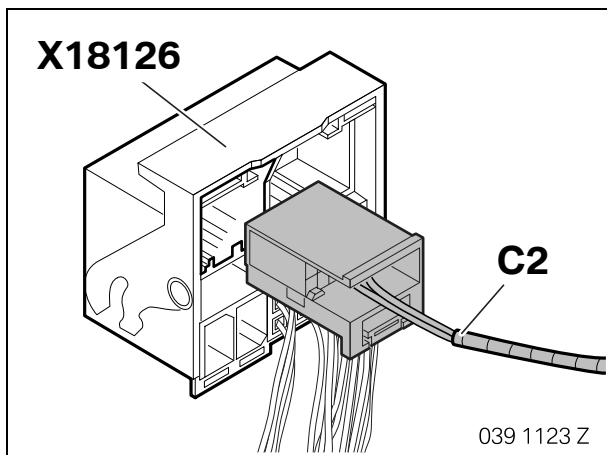

**Cars with SA 661+650 only**

Connect branch **C2** to plug **X18126**.

▶ If plug **X13321** is already in the car, the cables from branch **C2** must be disconnected and connected to the same pins in the plug in the car **X13321**. ◀

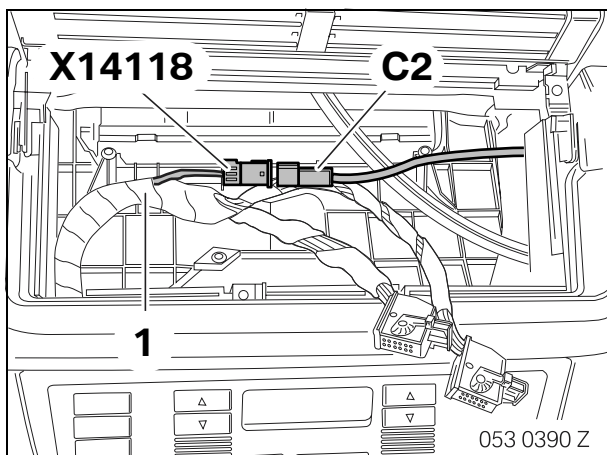

**Cars with SA 602/609 only**

Connect branch **C2** to tied back plug **X14118**.

## 7. To install and connect the AUX connector wiring harness in E83 cars

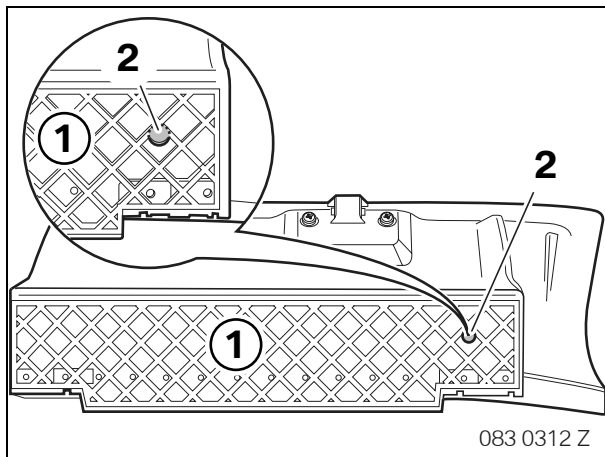

☐ All holes must be drilled precisely as shown in the illustration. ◀

Drill a hole (2) in the rear of the glove compartment (1) with an 8 mm twist drill bit.

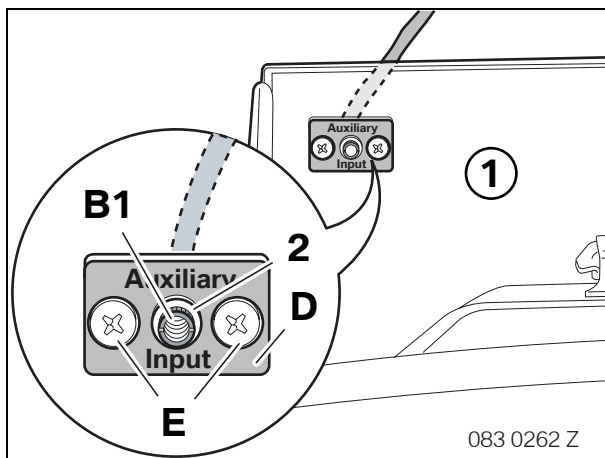

Insert branch **B1** in the glove compartment (1) and secure it to mounting plate **D** with a knurled nut (2).

Mark the mounting holes and drill them with a 3 mm twist drill bit.

Secure mounting plate **D** to the glove compartment (1) using Philips screws **E**.

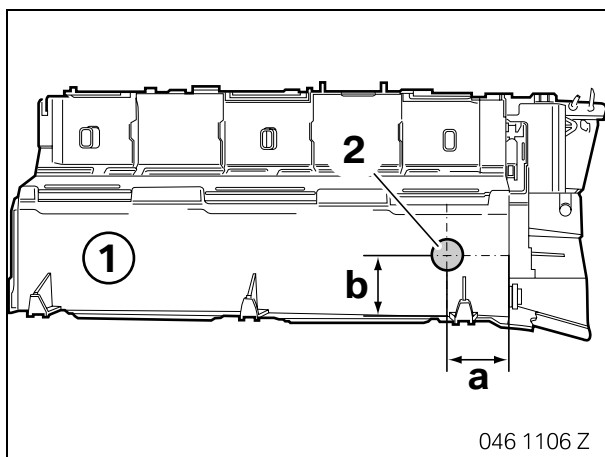

Drill a hole (2) in the trim (1) with a 3 mm twist drill bit through which you can thread the AUX connector wiring harness.

Dimension **a**: 40 mm

Dimension **b**: 45 mm

Enlarge the hole (2) to a diameter of 20 mm.

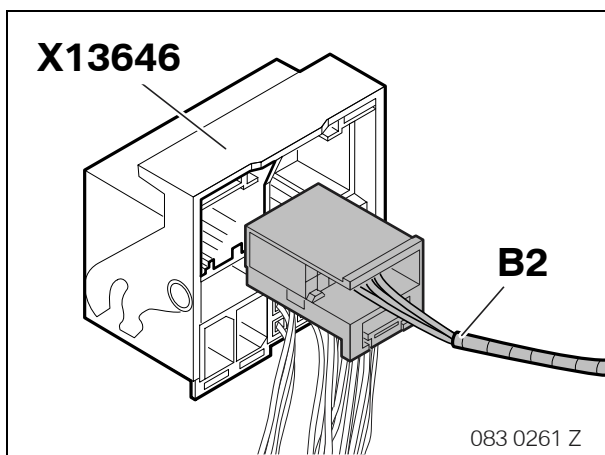

Connect branch **B2** to plug **X13646**.

☐ If plug **X13649** is already in the car, the cables from branch **B2** must be disconnected and connected to the same pins in the plug in the car **X13649**. ◀

## 8. To install and connect the AUX connector wiring harness in E85 cars

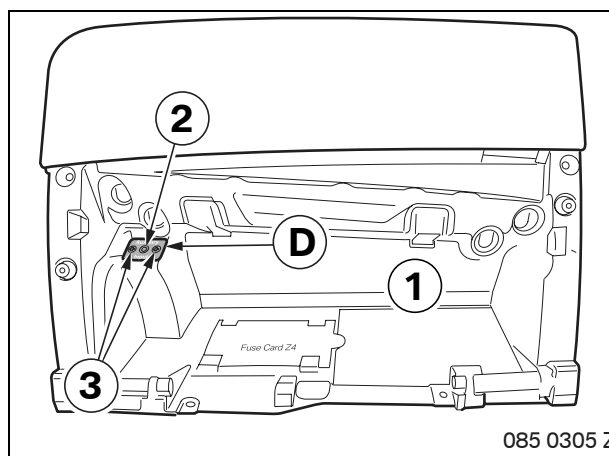

▶ All holes must be drilled precisely as shown in the illustration. ◀

Put on mounting plate **D** in the glove compartment (1) and transfer the hole pattern.

Drill a hole (2) in the glove compartment (1) with an 8 mm twist drill bit.

Drill the holes (3) using a 3 mm twist drill bit.

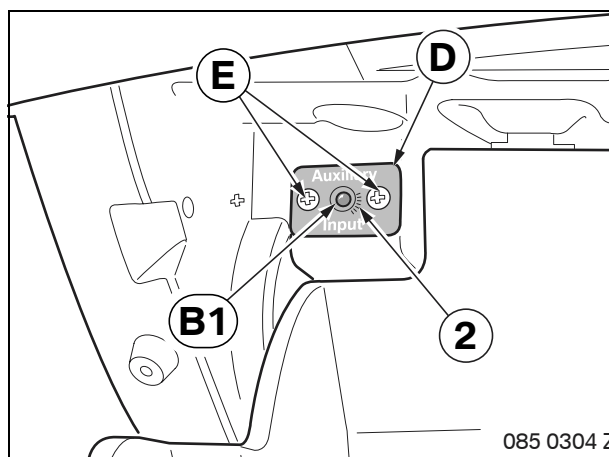

Insert branch **B1** in the glove compartment (1) and secure it to mounting plate **D** with a knurled nut (2).

Secure mounting plate **D** to the glove compartment (1) using Philips screws **E**.

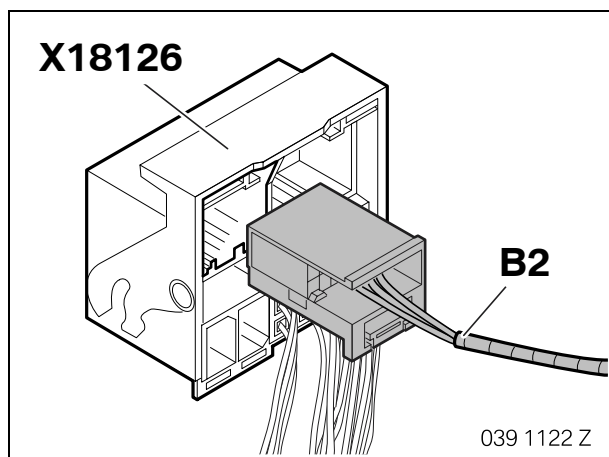

Connect branch **B2** to plug **X18126**.

▶ If plug **X13321** is already in the car, the cables from branch **B2** must be disconnected and connected to the same pins in the plug in the car **X13321**. ◀

## 9. Concluding work and coding

 This retrofit system does not require coding. ◀

- Connect battery
- Conduct a brief test with DIS/GT1
- Conduct a function test:
- Connect the external audio source to the pawl socket in the glove compartment
- Press the "MODE" key several times until "AUX" appears on the display
- Start playing the external audio source

 The volume and tone can be controlled using the radio.

The audio signals from the external audio source are interrupted whenever there is a traffic announcement. ◀

- Re-assemble the car

## 10. Circuit diagram

### E46 with SA 661+650 only

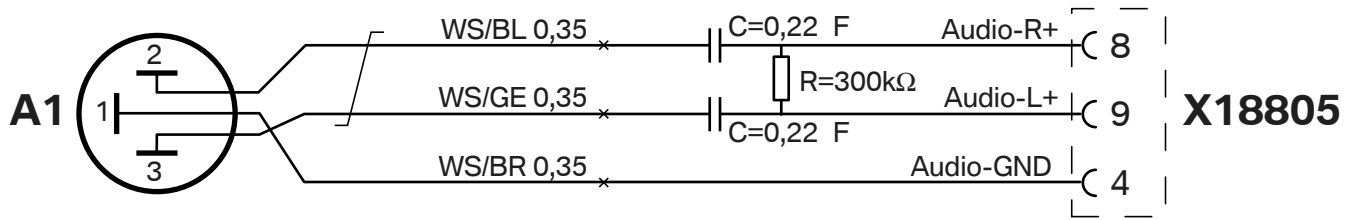

046 1124 Z

### E39/E53 with SA 661+650 and E83/E85 with SA 662 only

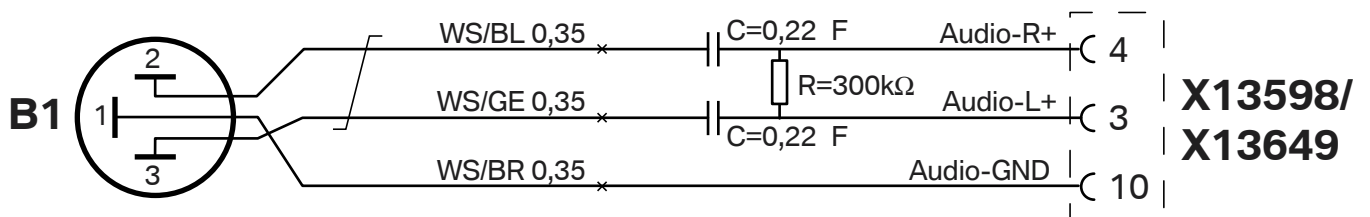

046 1125 Z

### E39/E46/E53 with SA 602/609 only

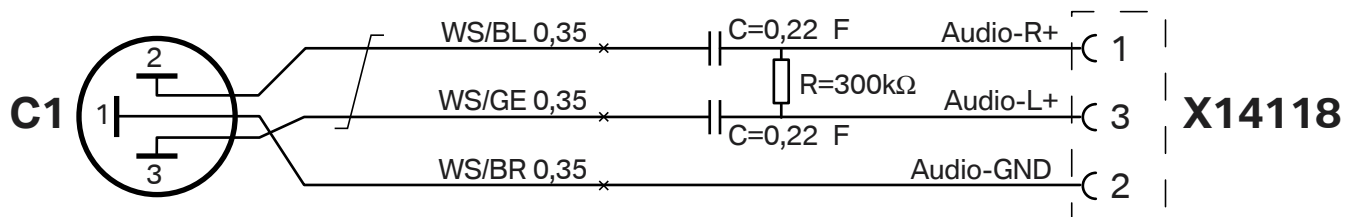

046 1126 Z

### Legend

A1	Pawl plug 3.5 mm
X18805	Green 10-pin socket casing
B1	Pawl plug 3.5 mm
X13598	Black 12-pin socket casing
X13649	Black 12-pin socket casing
C1	Pawl plug 3.5 mm
X14118	Black 3-pin plug casing

### Cable colours

BL	blue
BR	brown
GE	yellow
GR	grey
SW	black
WS	white