**Special tools required:**

- 25 1 120

*Necessary preliminary tasks:*

- Remove underbody protection.
- Detach exhaust system from catalytic converter.
- Remove exhaust bracket from transmission and exhaust.
- Lower exhaust system at front.

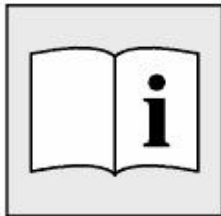
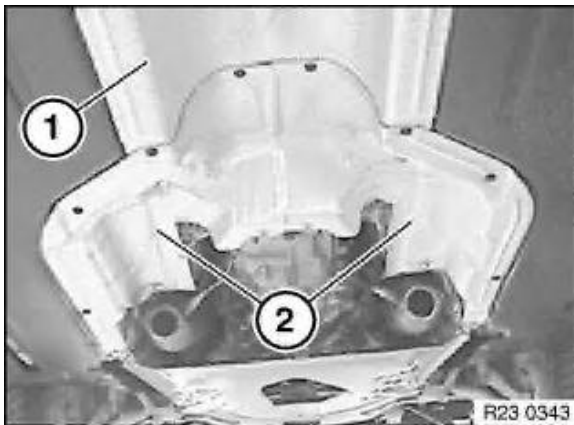

Remove heat shields (1) and (2).



Detach knob with a firm tug.

Note:

Do not turn knob when detaching as this will shear off the turning lock in the knob.

Installation:

Fit knob on shift lever, align and press on until it snaps noticeably into place.

Note:

Illustration shows E46.

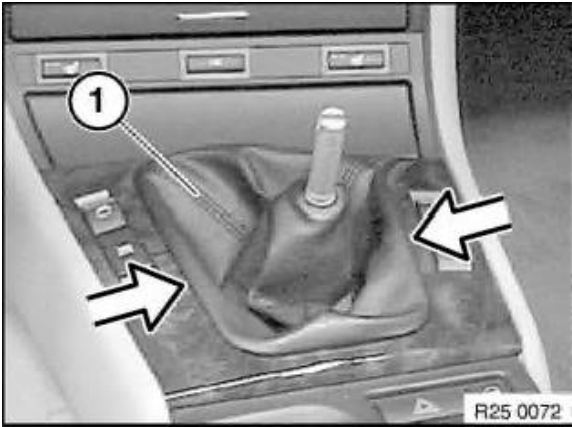

Press installation frame of rubber gaiter (1) together a little and remove rubber gaiter (1) from center console.

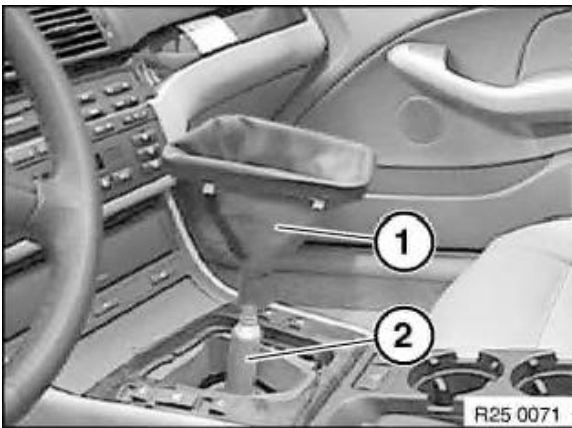

Installation:

Feed gaiter (1) downwards and fit on shift lever (2).

Pull rubber gaiter (1) over selector lever and insert in center console.

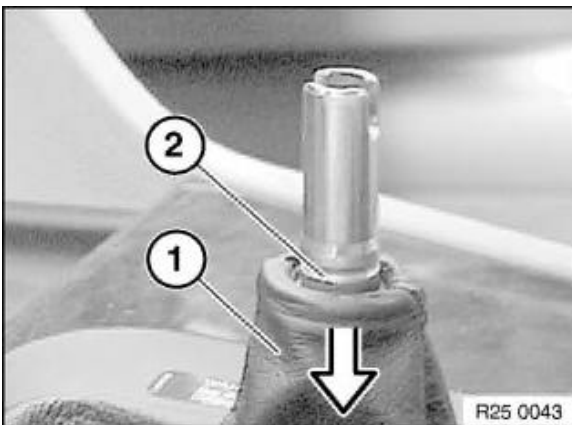

Installation:

Push rubber gaiter (1) down until groove (2) is fully exposed.

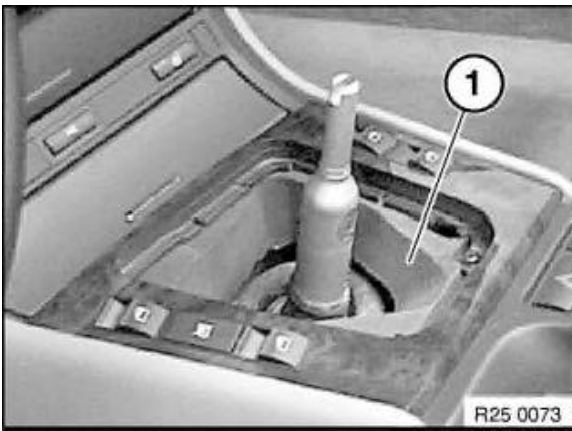

Remove soundproofing (1).

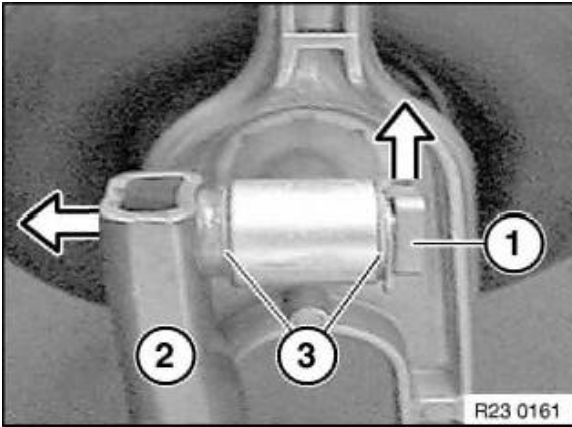

Lift off retainer (1).
Remove shims (3).
Remove selector rod (2).

Installation:

Grease shift rod pin.
Grease, refer to BMW Service Operating Fluids.
Make sure shims (3) are in correct position.

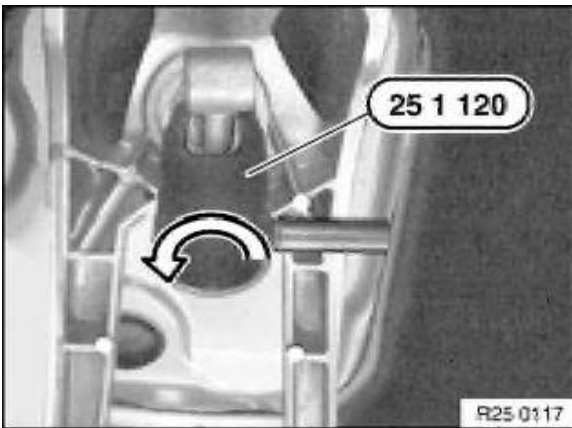

Insert special tool 25 1 120 in mounting and turn 90° counterclockwise.
Press mount upwards out of shift arm.

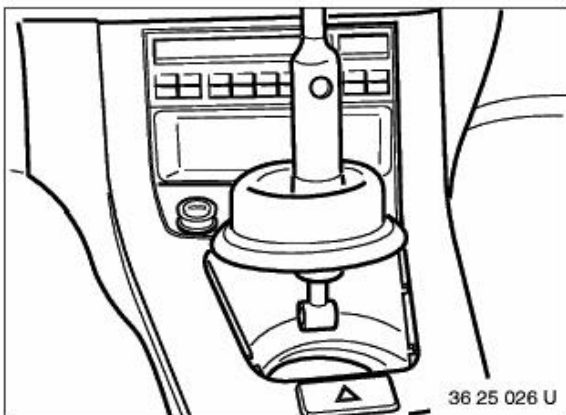

Remove rubber gaiter from body cutout and lift out with selector lever.

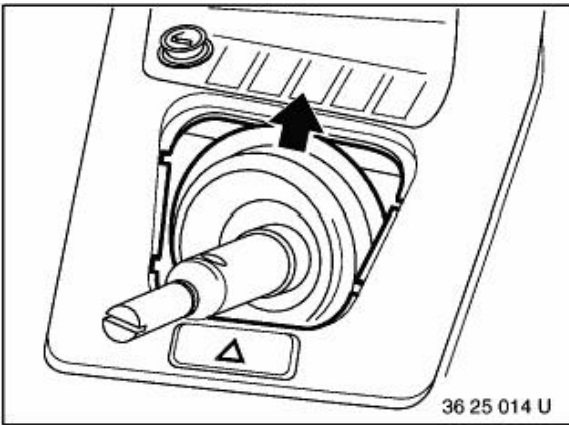

Installation:

Insert rubber gaiter with arrow in direction of travel towards front.

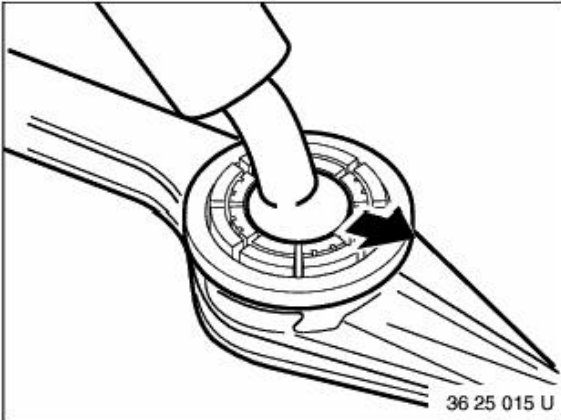

Installation:

Grease selector lever ball.

Grease, refer to BMW Service Operating Fluids.

Install selector lever in selector arm.

Align mount:

- Arrows on mount in longitudinal axis of vehicle.
- Retaining lugs of mount, transverse to direction of travel.

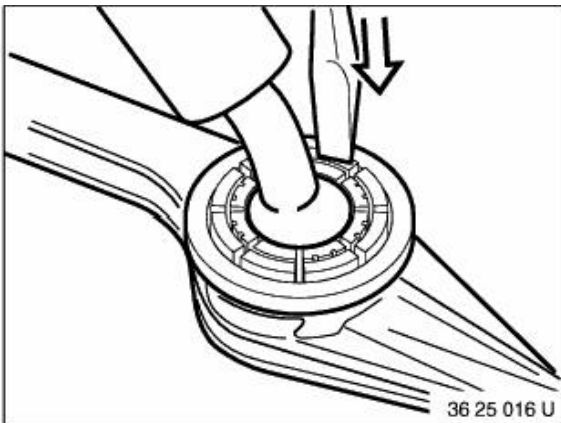

Installation:

Press mount in area of retaining lugs into selector arm until it audibly snaps into place.

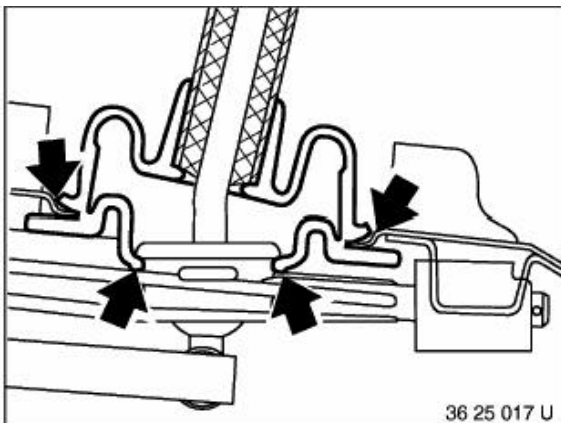

Installation:

Pull inner rubber gaiter over bowl on selector arm and press outer rubber gaiter into body cutout.

25 1 120 Pin wrench

Minimum set: Mechanical tools



Note: For removing gear lever (releasing gear lever bearing).

Series: E31, E36, E60, E61, E83, E85, E87, E90, E91, E92

Storage location: B19

SI number: 1 17 05 (212)

Order number: 25 1 120
Pin wrench

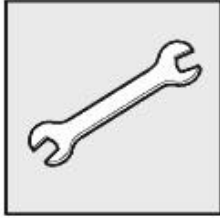
**Special tools required:**

- 31 2 220

**Warning!**

Scalding hazard!

Only perform this work after engine has cooled down.

Danger of injury!

Removal of the exhaust system must be carried out with the assistance of a second person.

Weight of exhaust system is approx. 40 kg.

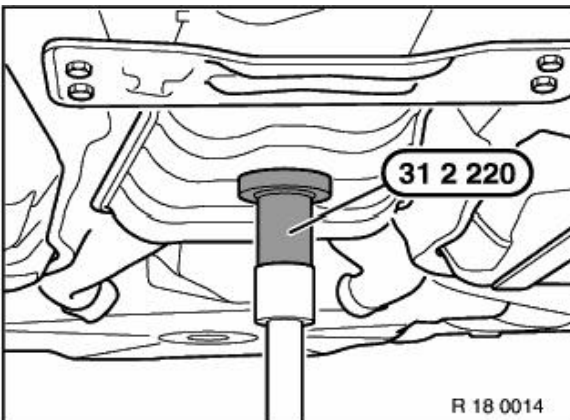

Support exhaust system with special tool 31 2 220 .

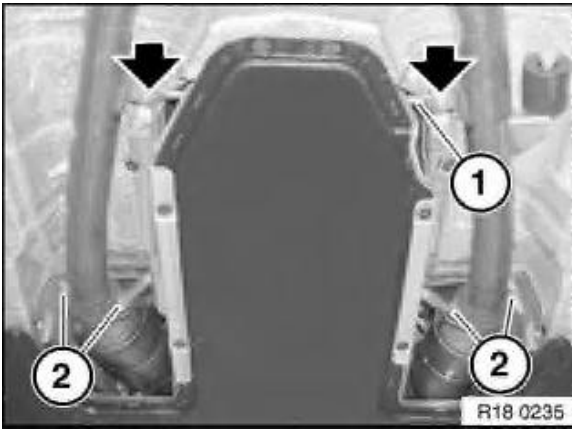

Unscrew nuts (1).
Unscrew nuts (2).

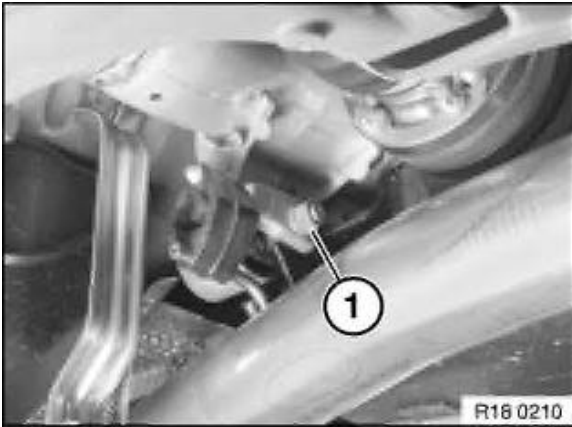

Unscrew nut (1).

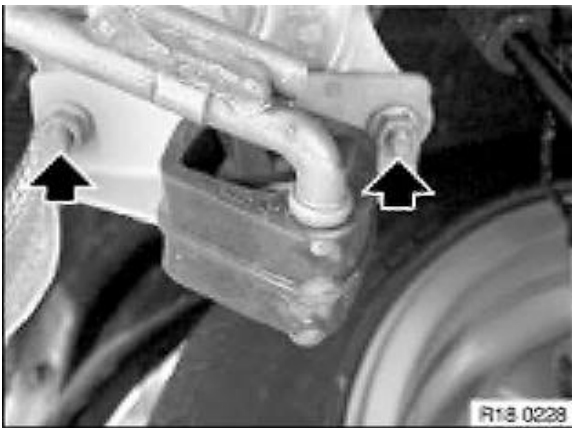

Unscrew nuts.

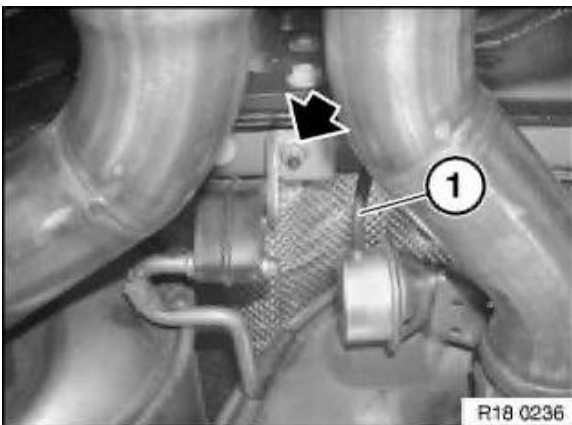

Detach hose (1) of vacuum unit.
Unfasten nut.

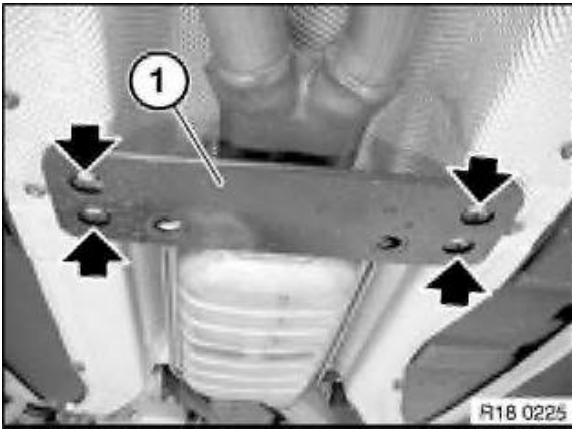

Unfasten screws.

Remove reinforcement plate (1).

Lower exhaust system carefully.

1.0 Greasing and assembling gearshift components

Use the lubricants listed below for all work on external gearshift components of manual and automatic transmissions (ball sockets, bearing bushes, shift linkages etc.), as described in the relevant Repair Instructions:

Greasing:

Tradename

Klüber Poly lub GLY 801

Manufacturer/Supplier

Klüber

Assembling:

Tradename

Gleitmittel-Circolight

BMW Part Number

83 19 9 407 771