

Original BMW Accessory. Installation Instructions.



Professional Navigation system retrofit (SA 609) BMW 5 Series (E60, E61)

Retrofit kit No.	65 90 0 397 300	Professional Navigation retrofit kit
	65 90 0 413 216	Professional Navigation retrofit kit
	65 83 6 976 392	Retrofit kit activation code CCC voice

Installation time

The installation time for cars without SA 606 is **approx. 6 hours**. In cars with SA 606 the installation time is **approx. 4 hours**, but this may vary depending on the condition of the car and the equipment in it.

In general the car must be upgraded to the latest I stage status by flashing before starting the work. Depending on the production age of the car and the work already carried out on the car, the programming times will vary, which means that we cannot quote a specific time at this point. The installation time does not include any time for programming/encoding, as this depends on the age of the car and the equipment in it.

Important information

These installation instructions are primarily designed for use within the BMW dealership organisation and by authorised BMW service companies.

In any event, the target group for these installation instructions is specialist personnel trained on BMW cars with the appropriate specialist knowledge.

All work must be completed using the latest BMW repair manuals, circuit diagrams, servicing manuals and work instructions, in a rational order, using the prescribed tools (special tools) and observing current health and safety regulations.

If you experience installation or function problems, limit troubleshooting to approx. 0.5 hours for mechanical or 1.0 hour for electrical work.

In order to reduce costs and avoid any additional expense, send a query immediately to the Technical Parts Support via the Aftersales Assistance Portal (ASAP).

Specify the following information:

- Chassis number
- Part number of the retrofit kit
- A precise description of the problem
- Work steps already carried out

Do not archive the hard copy of these installation instructions since daily updates are made by ASAP!

Installation information

Ensure that the cables and/or lines are not kinked or damaged as you install them in the car. The costs thereby incurred will not be reimbursed by BMW AG.

Additional cables/lines that you install must be secured with cable ties.

If the specified PIN chambers are occupied, bridges, double crimps or twin-lead terminals must be used.

All pictures show LHD cars; proceed accordingly on RHD cars.

Ordering instructions

An activation code (FSC) with part number 65 83 6 976 392 will be required for the use of the SA 620 in connection with the Professional navigation system (CCC/SA609).

This activation code must be copied into the car with the aid of the action plan, via the dealer's programming system. If the code is not transferred to the car, the SA 620 can no longer be used.

Ordering and delivery of the FSC

- The activation codes are "coded outsourced parts", i.e. FSCs are always generated for a specific vehicle and must therefore be ordered from BMW as FSI parts (Production – Line Section – Invest) quoting the chassis number.
- The FSCs are delivered in the BMW After Sales Portal (ASAP) under Parts and Accessories (Sweeping Technologies). The dealership organisations can download the FSC from the Internet to their PC. This code (3 files) must then be stored on media such as a CD before it can be copied via the programming system into the car.

Pictograms



Denotes instructions that draw your attention to dangers.



Denotes instructions that draw your attention to special features.

- ◀ Denotes the end of the instruction or other text.

Do not archive the hard copy of these installation instructions since daily updates are made by Aftersales Portal.

Special tools required

00 9 310

Table of contents

Section	Page
1. Parts list	4
2. Preparatory work	6
3. Connection diagram	7
4. Installation and cabling diagram	8
5. Installation work for the GPS aerial and aerial cable (cars without SA 606 only)	9
6. Installation work for Car Communication Computer (CCC)	11
7. Concluding work and coding	17
8. Circuit diagram	18

1. Parts list

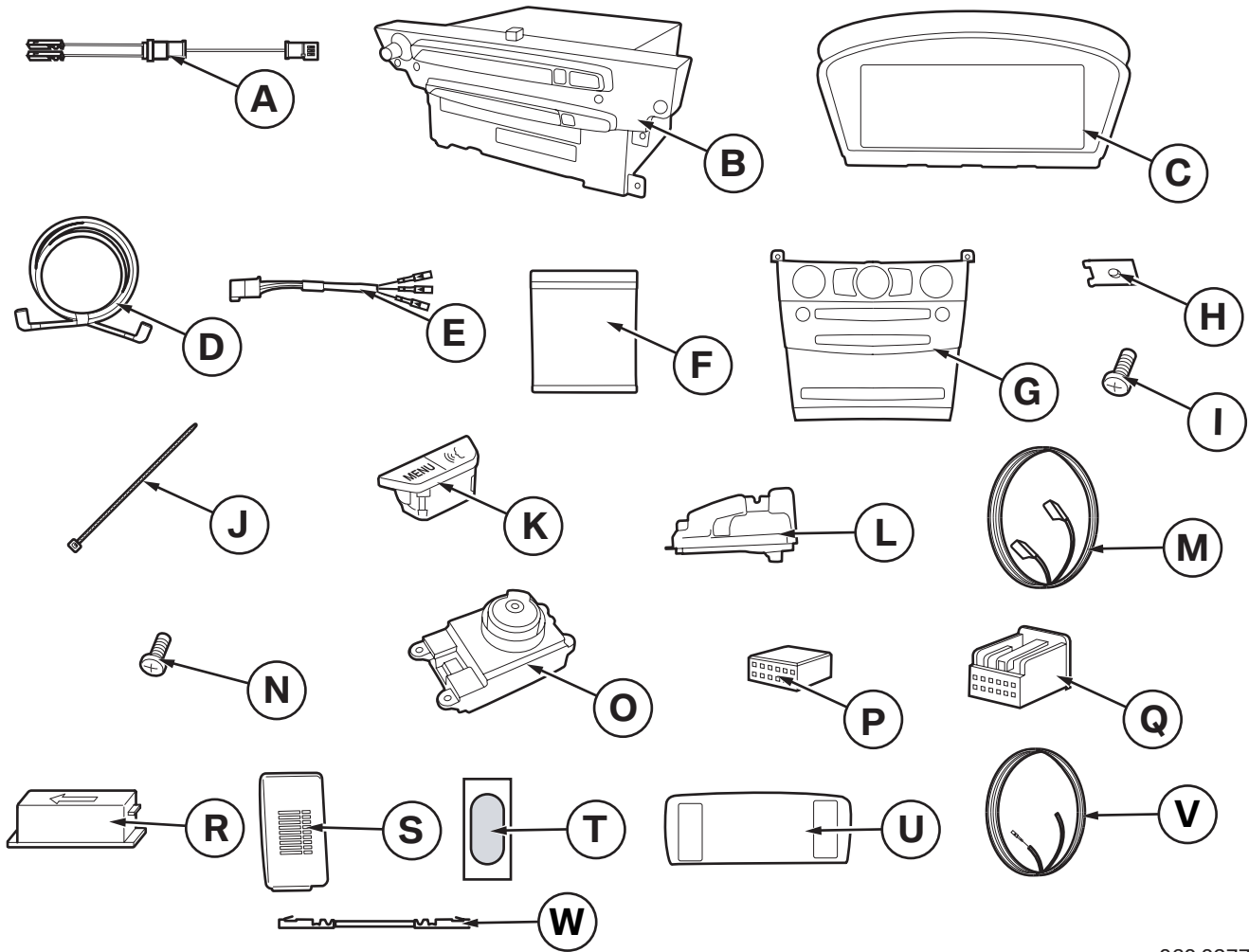

060 0277 V

Legend

- A Voice control wiring harness
- B Car Communication Computer (CCC)
- C 8.8" on-board monitor
- D LVDS cable
- E CCC fan wiring harness
- F Protective strip
- G Central instrument panel trim (not included in the parts kit)
- H Speed nut (2x)
- I Fillister head self-tapping screw 4.2 x 16 (3x)
- J Cable tie (15x)
- K Menu/voice input button
- L GPS aerial (included in navigation system retrofit parts kit)
- M GPS aerial cable (included in navigation system retrofit parts kit)
- N Self-tapping screw (included in navigation system retrofit parts kit)
- O Controller high
- P Socket casing (3x)
- Q Cover cap (3x)

1. Parts list

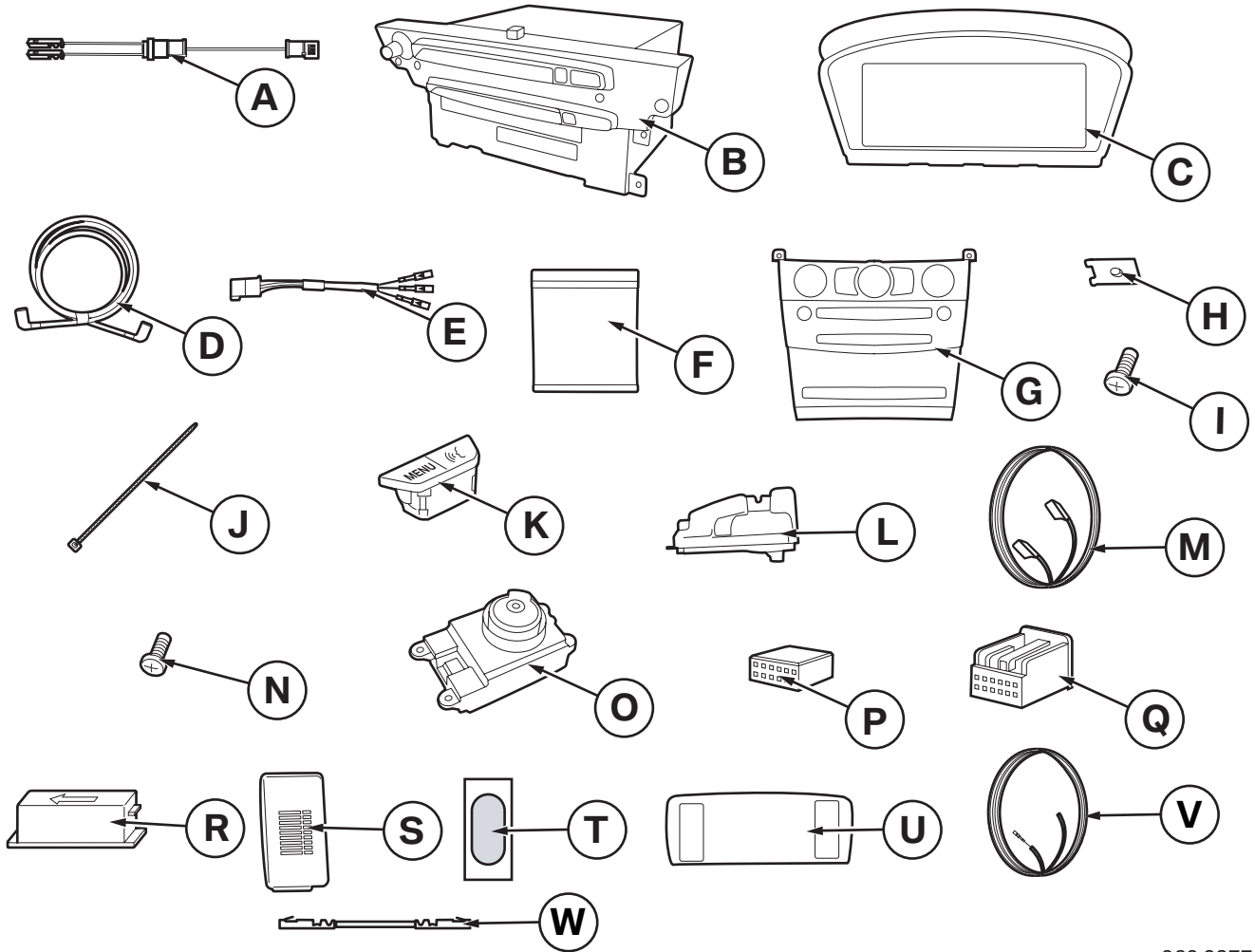

060 0277 V

- R Hands-free microphone
- S Hands-free microphone trim
- T Microphone trim (cars without SA 638 or SA 644 only)
- U Headlining trim
(cars without SA 638 or SA 644 only, not supplied in the retrofit kit)
- V Navigation system cable
- W Connection cable (or cars built after 09/2005 only)

2. Preparatory work

	TIS no.
Conduct a brief test	---
Disconnect negative pole of battery	12 00 ...
The following components must be removed first of all	
Rear seat (cars without SA 606 only)	52 24 005
Backrest side part (cars without SA 606 only)	52 26 008
Oddments box on the driver's side	51 16 ...
Side footwell trim on A pillar	51 43 070
Trim for door pillar at the bottom	51 43 150
Trim for roof pillar, rear (cars without SA 606 only)	51 43 251
Trim for roof pillar, rear (front) (cars without SA 606 only)	51 43 255
Audio system controller	65 12 200
Lower rear headlining (cars without SA 606 only)	---
Trim for C pillar (E61) (cars without SA 606 only)	51 43 255
Trim for D pillar (E61) (cars without SA 606 only)	51 45 259
Décor trim on right of instrument panel	51 45 380
Central instrument panel cover	51 45 310
On-board monitor	65 82 050
Pedal trim	51 45 185
Button unit	61 31 193
Button for controller	61 31 192
Front controller	61 31 195
Remove the oddments box	51 16 200
Lower the A pillar trim on the left	---
Front headlining trim	---

3. Connection diagram

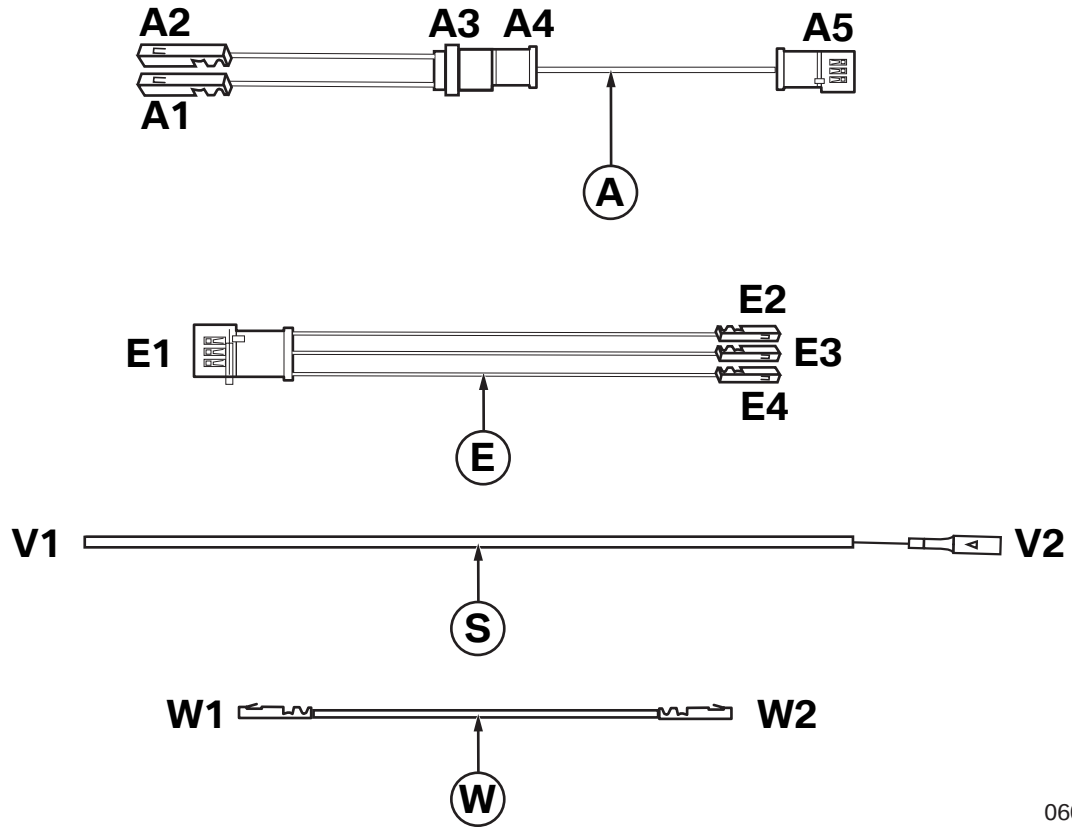

060 0278 V

Item	Designation	Signal	Cable colour / Cross-section	Connection location in the car	Abbreviation / Slot
A	Voice control wiring harness	---	---	---	---
A1	Socket contact	MIC (+)	WS/GN 0.35 mm ²	To radio plug X13814	X13814 PIN 1
A2	Socket contact	MIC (-)	WS/RT 0.35 mm ²	To radio plug X13814	X13814 PIN 6
A3	White 3-pin plug casing	---	---	To branch A4	X13293
A4	3-pin socket casing, WS	---	---	To branch A3	X3759
A5	3-pin socket casing, SW	---	---	To hands-free microphone R	X2759
E	CCC fan wiring harness	---	---	---	---
E1	3-pin socket casing, SW	---	---	To CCC fan	X14055
E2	Socket contact	Fan (+)	RT/SW 0.35 mm ²	To radio plug X13813	X13813 PIN 1
E3	Socket contact	Fan (-)	BR 0.35 mm ²	To radio plug X13813	X13813 PIN 5
E4	Socket contact	Diagnosti c	WS 0.35 mm ²	To radio plug X13813	X13813 PIN 11
V	Navigation system wiring harness	---	---	---	---
V1	Cable open	---	BRRT 0.35 mm ²	To CAS control module	X10318 PIN 31
V2	Socket contact	DFAHL	BRRT 0.35 mm ²	To radio plug X13814	X13814 PIN 12
W	Connection cable	---	---	Cars after 09/2005 only	---
W1	Socket contact	PTT	WSGE 0.35 mm ²	To iDrive A167 , 8-pin SW plug	X10387 PIN 6
W2	Socket contact	PTT	WSGE 0.35 mm ²	To Menu/Voice input button K , black 4-pin plug	X14099 PIN 2

4. Installation and cabling diagram

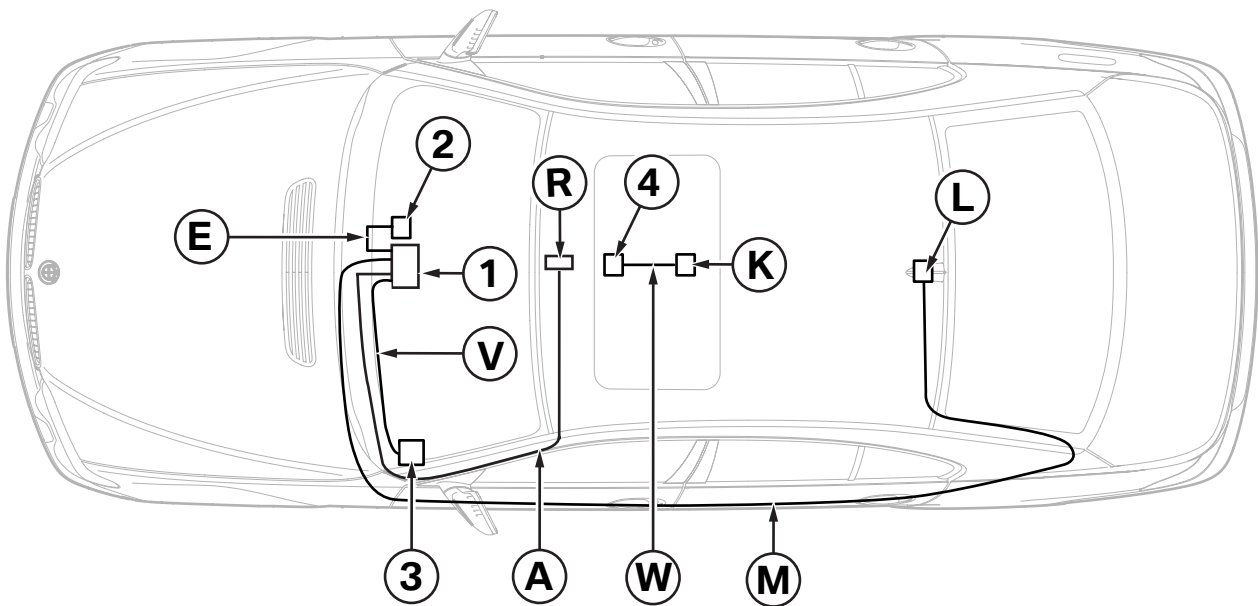

060 0279 V

Legend

- A Voice control wiring harness
- E CCC fan wiring harness
- L GPS aerial
- K Menu/voice input button
- M GPS aerial cable (for cars without SA 606 only)
- R Hands-free microphone
- V Navigation system wiring harness
- W Connection cable (for cars built after 09/2005 only)

- 1 CCC
- 2 CCC fan
- 3 CAS
- 4 iDrive

5. Installation work for the GPS aerial and aerial cable (cars without SA 606 only)

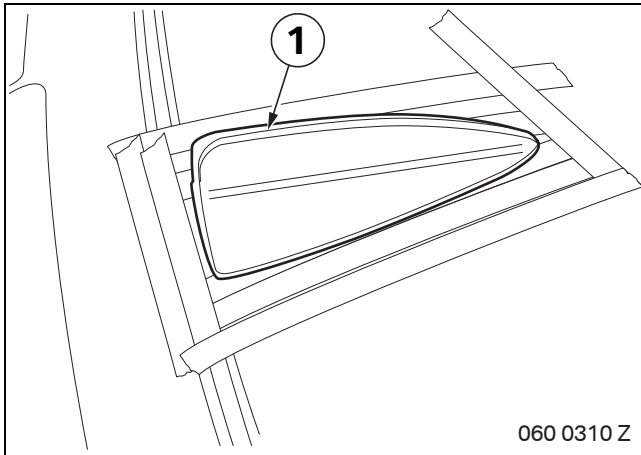

- ▶ Mask the area around the roof aerial to prevent damaging the paintwork. ◀

Carefully cut the empty casing (1) for the roof aerial off the roof with the special tool.

Clean the surfaces in the bonding areas on the empty casing (1) and roof.

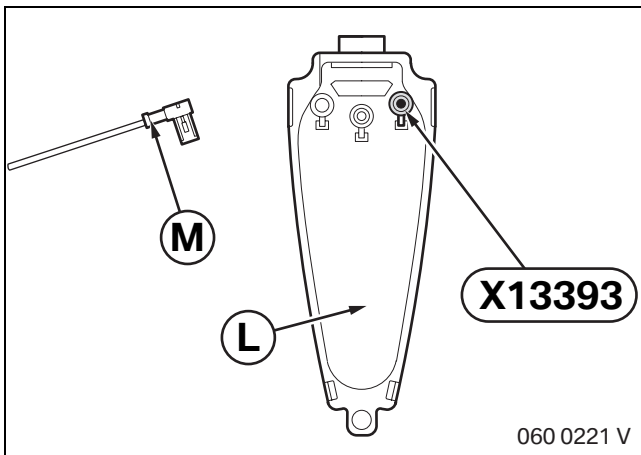

- ▶ If the car has a car phone the existing aerial must be replaced by the GPS aerial.

The aerial cable from the car phone must then be connected to the GPS aerial L. ◀

Connect the GPS aerial cable M to connector X13393 on the GPS aerial L.

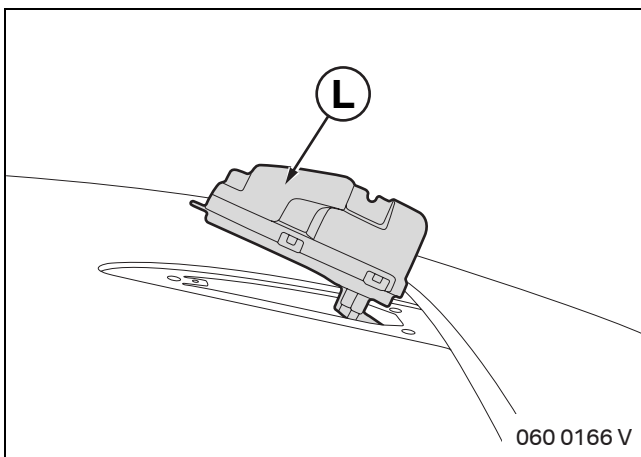

Insert the aerial L at the rear and secure it at the front with screw N supplied in the parts kit.

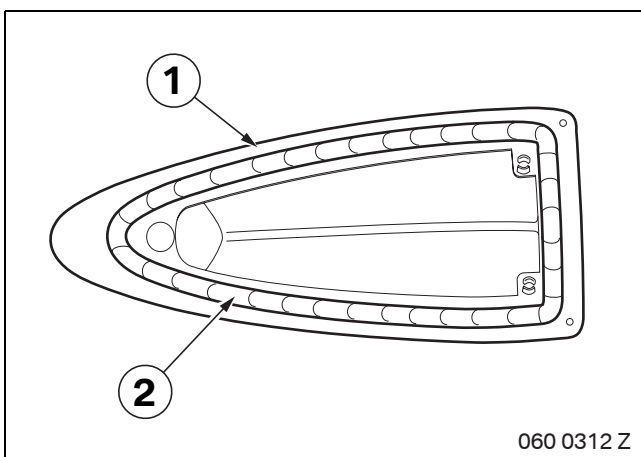

- ▶ The bonding surfaces must be clean and free of grease. The temperature of the adhesive must be at least 20 °C. The hardening time of the adhesive is at least 4 hours. ◀

Apply a bead of adhesive (2) around 8 mm wide and 8 mm high to the empty casing (1).

Carefully place the empty casing (1) in its original position, press lightly and secure it with adhesive tape.

5. Installation work for the GPS aerial and aerial cable (cars without SA 606 only)

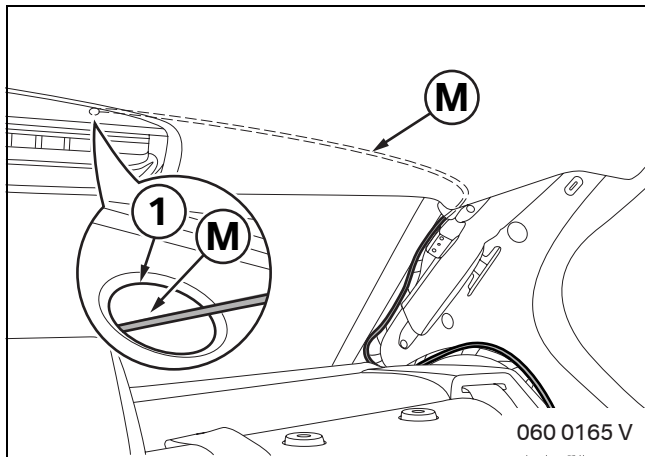

For E60 only:

Thread the aerial cable **M** through the opening (1).

Route the aerial cable **M** behind the headlining to the C pillar. Route the aerial cable **M** further along the existing standard wiring harness to the driver's footwell and from there to the centre console.

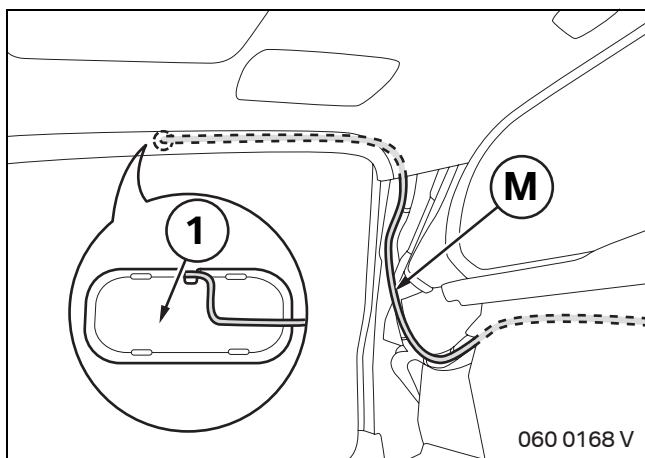

For E61 only:

Thread the aerial cable **M** through the opening (1).

Route the aerial cable **M** behind the headlining to the D pillar. Route the aerial cable **M** further along the existing standard wiring harness to the driver's footwell and from there to the centre console.

Cut the cover cap (1) if necessary.

6. Installation work for the Car Communication Computer (CCC)

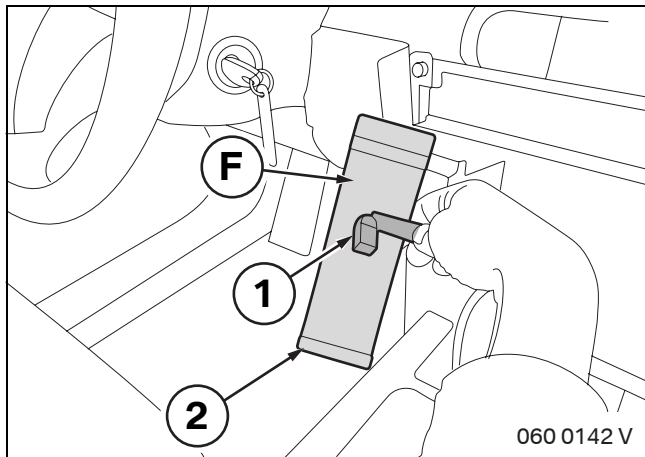

Cut the protective strip **F** at right angles to the adhesive strips in the middle.

Wrap the plug (1) on the existing LVDS cable with a protective strip **F** and secure it with adhesive strips (2).

Proceed in the same way with the plug on the LVDS cable on the audio system controller.

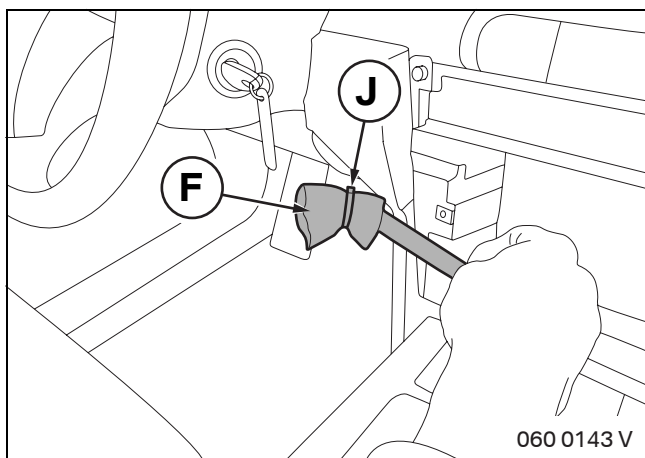

Also secure protective strip **F** using cable tie **J**.

Proceed in the same way with the plug on the LVDS cable on the audio system controller.

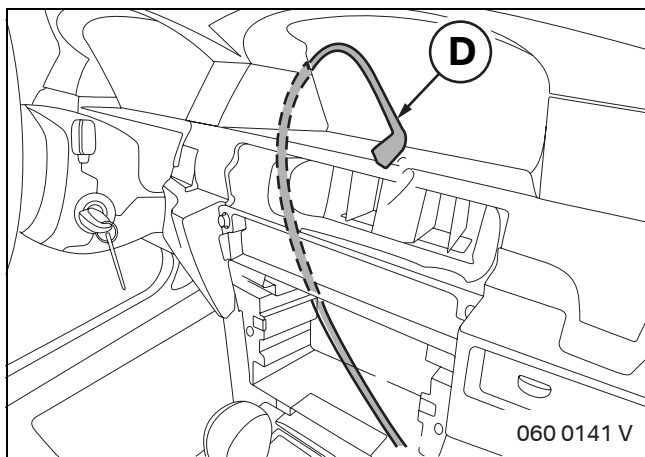

! Connect the violet plug later to the 8.8" on-board monitor **C** and connect the blue plug to CCC **B**. ◀

Route the LVDS cable **D** on the left behind the ventilation duct downwards to the centre console module holder.

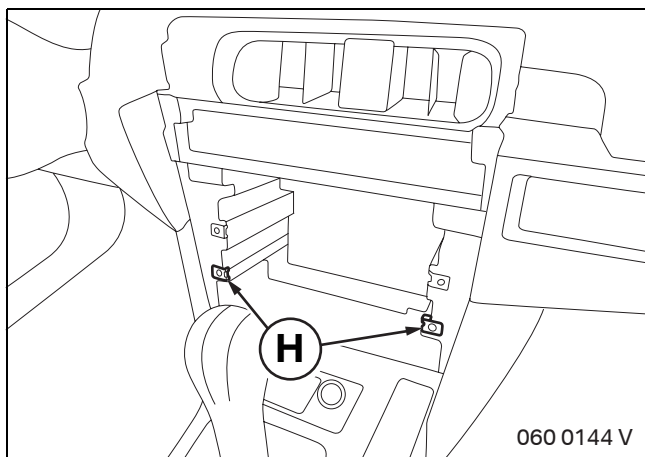

Attach speed nuts **H** to the centre console module holder.

6. Installation work for the Car Communication Computer (CCC)

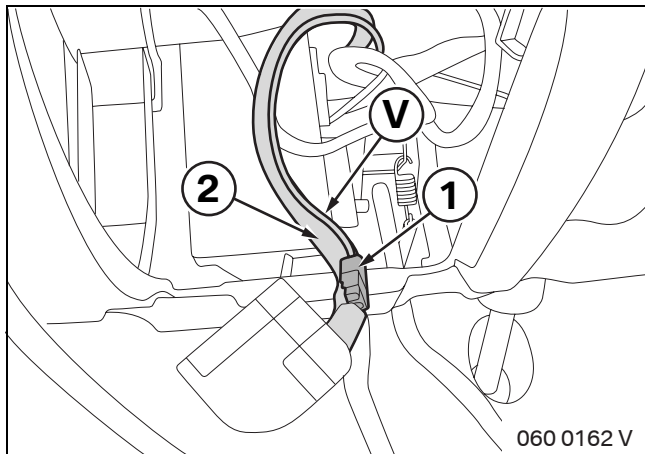

For cars built before 09/2004 only:

Disconnect plug **X10318** from the CAS control module. Connect the navigation system cable **V** to PIN 31, BR/RT cable, using a miniature connector (1).

Route the navigation system cable **V** along the existing wiring harness (2) to the steering column.

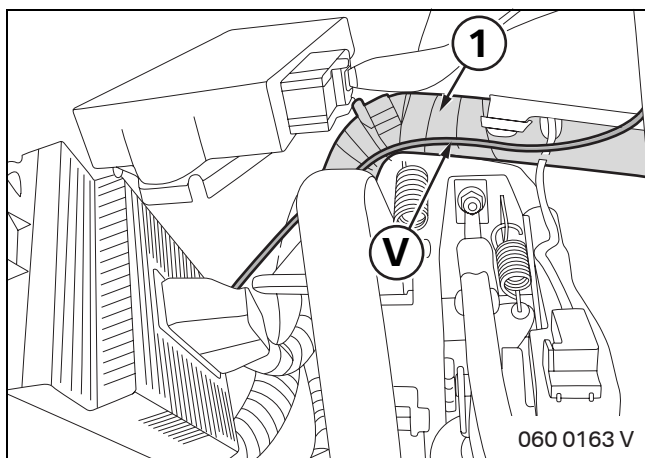

Route the navigation system cable **V** along the existing wiring harness (1) to the centre console.

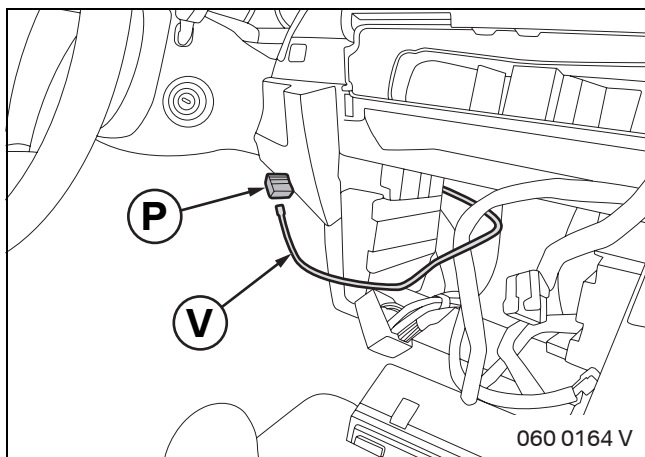

▶ If the socket casing **X13814** is already on the radio plug, connect the navigation system cable **V** to PIN 12. ◀

Connect the navigation system cable **V** to socket casing **P** PIN 12. Insert the socket casing **P** into the cover cap **Q**.

6. Installation work for the Car Communication Computer (CCC)

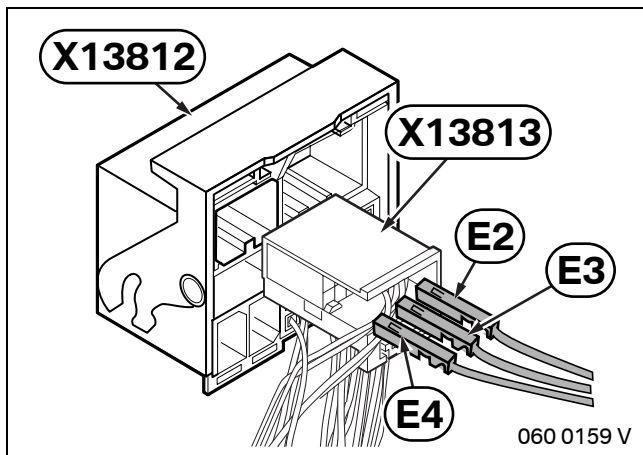

For all cars:

Disconnect plug **X13813** from plug **X13812**.

Connect the CCC fan wiring harness **E** to plug **X13813** as follows:

RTSW cable to PIN 1

BR cable to PIN 5

WS cable to PIN 11.

 If the car does not contain plug **X13813**, use socket casing **P**. ◀

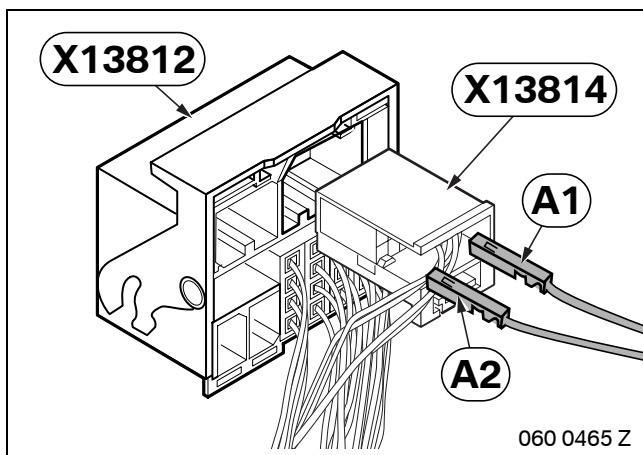

Disconnect plug **X13814** from plug **X13812**.

Connect branches **A1–A2** to plug **X13814** as follows:

- **A1**, white/green cable, to PIN 1

- **A2**, white/red cable, to PIN 6

Connect plug **X13814** to plug **X13812**

 If the car does not contain plug **X13814**, use socket casing **P**. ◀

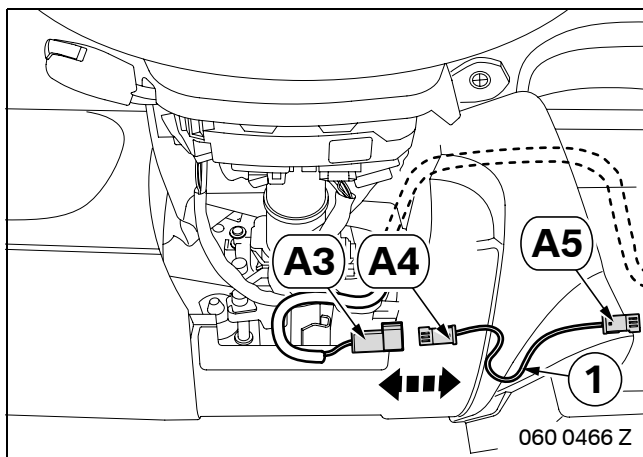

Route branches **A3–A5** to the steering column.

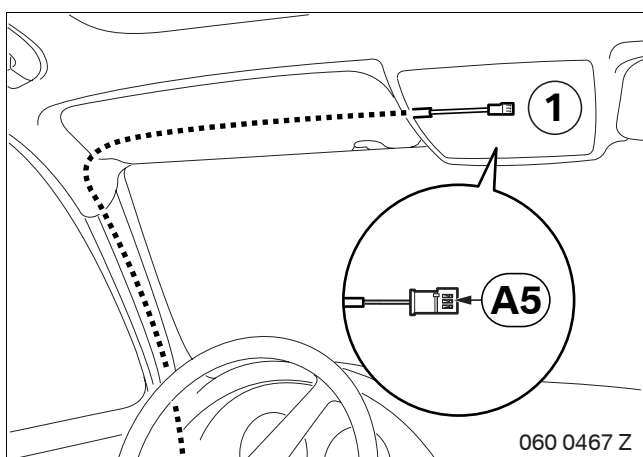

Route branch **A5** to the left A pillar over the lowered headlining to the opening of the roof trim (1).

6. Installation work for the Car Communication Computer (CCC)

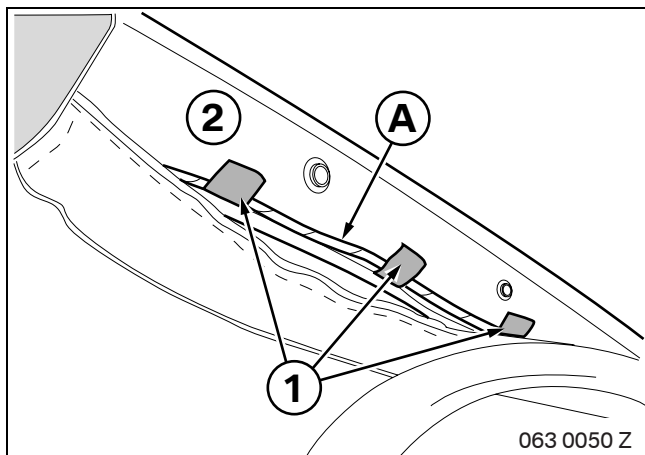

Secure wiring harness **A** to the left A pillar (**2**) using textile adhesive tape.

▶ Ensure that wiring harness **A** is routed and secured behind the head airbag. ◀

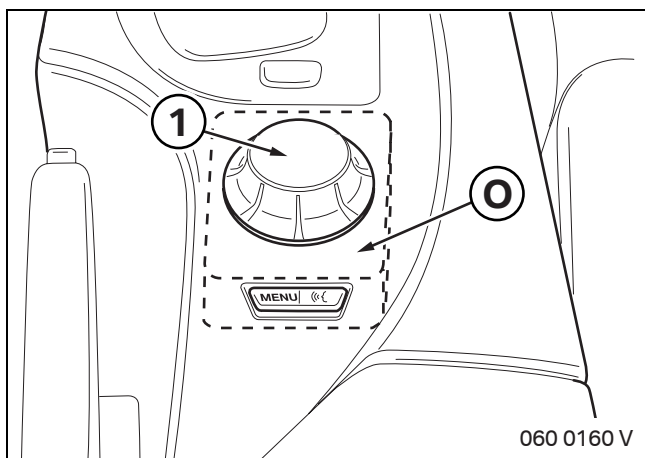

Install controller **O** from the parts kit as described in TIS No. 61 31 195.

Fit the knob for the controller (**1**) again as described in TIS No. 61 31 192.

Install the oddments box as described in TIS No. 51 16 200.

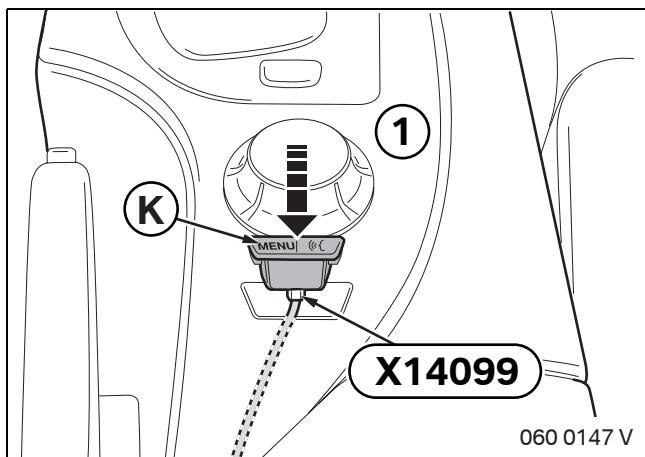

For cars built before 09/2005 only:

Connect plug **X14099** to Menu/Voice input button **K**. Clip the Menu/Voice input button **K** into the centre console (**1**).

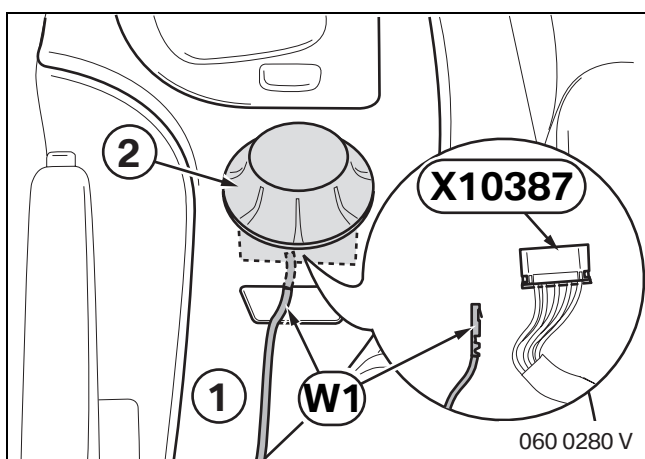

For cars built after 09/2005 only:

▶ Remove trim for storage compartment (**1**) as per TIS No. 51 16 211. ◀

Disconnect plug **X10387** (8-pin SW) from the iDrive (**2**).

Connect branch **W1**, WS/GE cable, to PIN 6

6. Installation work for the Car Communication Computer (CCC)

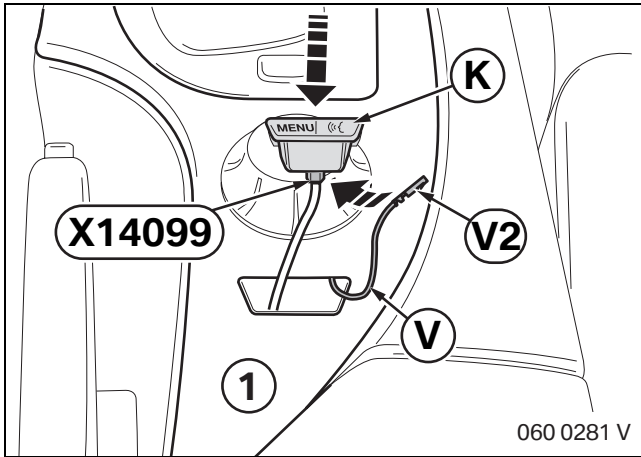

Connect branch **W2**, WS/GE cable, to PIN 2 of plug **X14099** (4-pin SW).

Connect plug **X14099** to Menu/Voice input button **K**.

Tie back the excess length of connection cable **W**.

Clip the Menu/Voice input button **K** into the trim for the storage compartment (1).

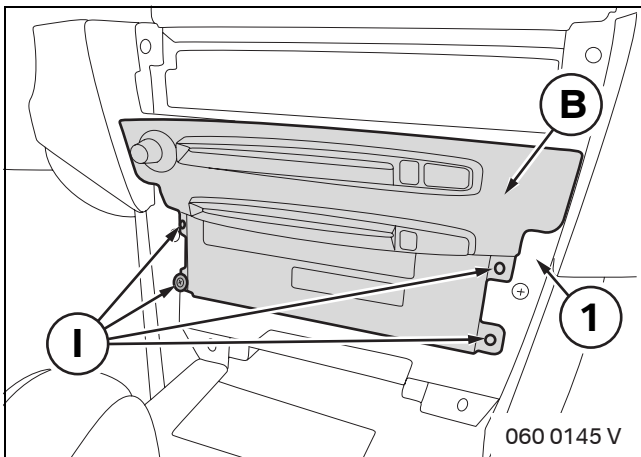

For all cars:

Connect all connectors to the CCC **B**.

Connect branch **E1** to the CCC fan.

▶ Tie back the old LVDS cable on the standard wiring harness (see Figure 060 0142 V). Cut open a few centimetres of the wiring harness wrapping if necessary. ◀

⚠ As you insert the CCC **B**, ensure that the wiring harness does not get trapped and that no parts of the interior trim are damaged. ◀

Push the CCC **B** into the centre console module holder (1) and secure it using fillister head self-tapping screws **I**.

Tightening torque 2.1–2.5 Nm.

Clip the centre console switch centre and automatic air conditioning control into the new instrument panel centre trim **G**. Connect the cable and install the trim.

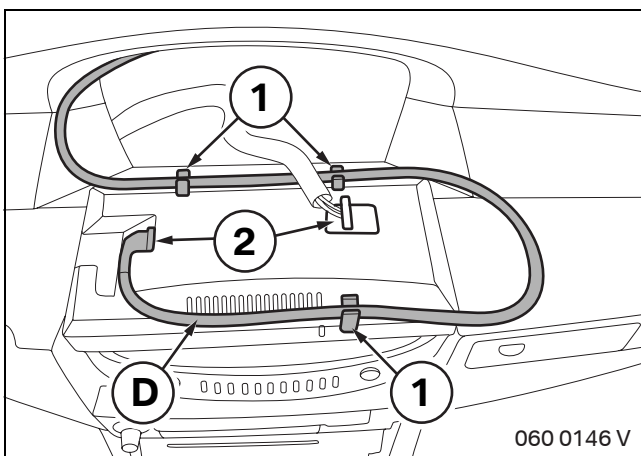

Secure LVDS cable **D** in a broad arc in the holders (1) of 8.8" on-board monitor **B**.

Connect the plug (2).

⚠ Take care not to kink LVDS cable **D** when you install the 8.8" on-board monitor **C**. ◀

▶ Tie back the old LVDS cable on the standard wiring harness (see figure 060 0142 V) in the area behind the 8.8" on-board monitor **C**. Cut open a few centimetres of the wiring harness wrapping if necessary. ◀

6. Installation work for the Car Communication Computer (CCC)

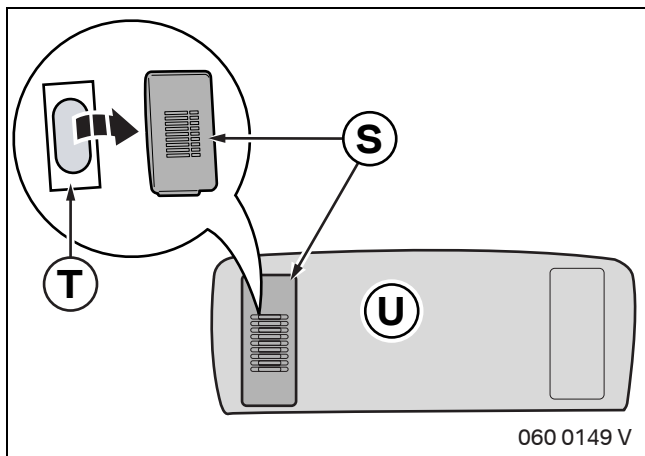

Cars without SA 638 or SA 644 only

Clip the microphone trim **T** into the hands-free microphone trim **S**.

Clip the hands-free microphone trim **S** into the headlining trim **U**.

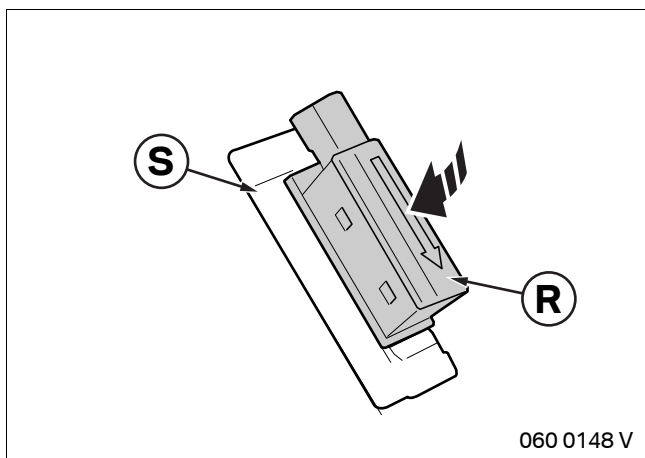

 The arrow on hands-free microphone **R** must point to the front of the car after it has been installed. ◀

Clip the hands-free microphone **R** into the hands-free microphone trim **S**.

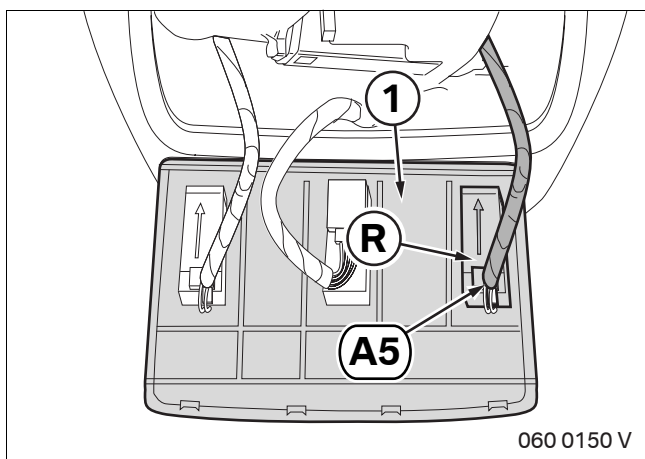

Clip the hands-free microphone **R** into the headlining trim (1) and connect branch **A5** to the hands-free microphone **R**.

7. Concluding work and coding

This retrofit system requires coding.

Ordering and delivery of the FSC

- The activation codes are “coded outsourced parts”, i.e. FSCs are always generated for a specific vehicle and must therefore be ordered from BMW as FSI parts (Production – Line Section – Invest) quoting the chassis number.
- The FSCs are delivered in the BMW After Sales Portal (ASAP) under Parts and Accessories (Sweeping Technologies). The dealership organisations can download the FSC from the Internet to their PC. This FSC (3 files) must then be stored on media such as a CD before it can be copied via the programming system into the car.

- Connect the battery
- Encode the retrofit via the **Retrofit/Nav Pro** path
- Conduct a brief test
- Conduct a function test
- Re-fit the car components as required

8. Circuit diagram

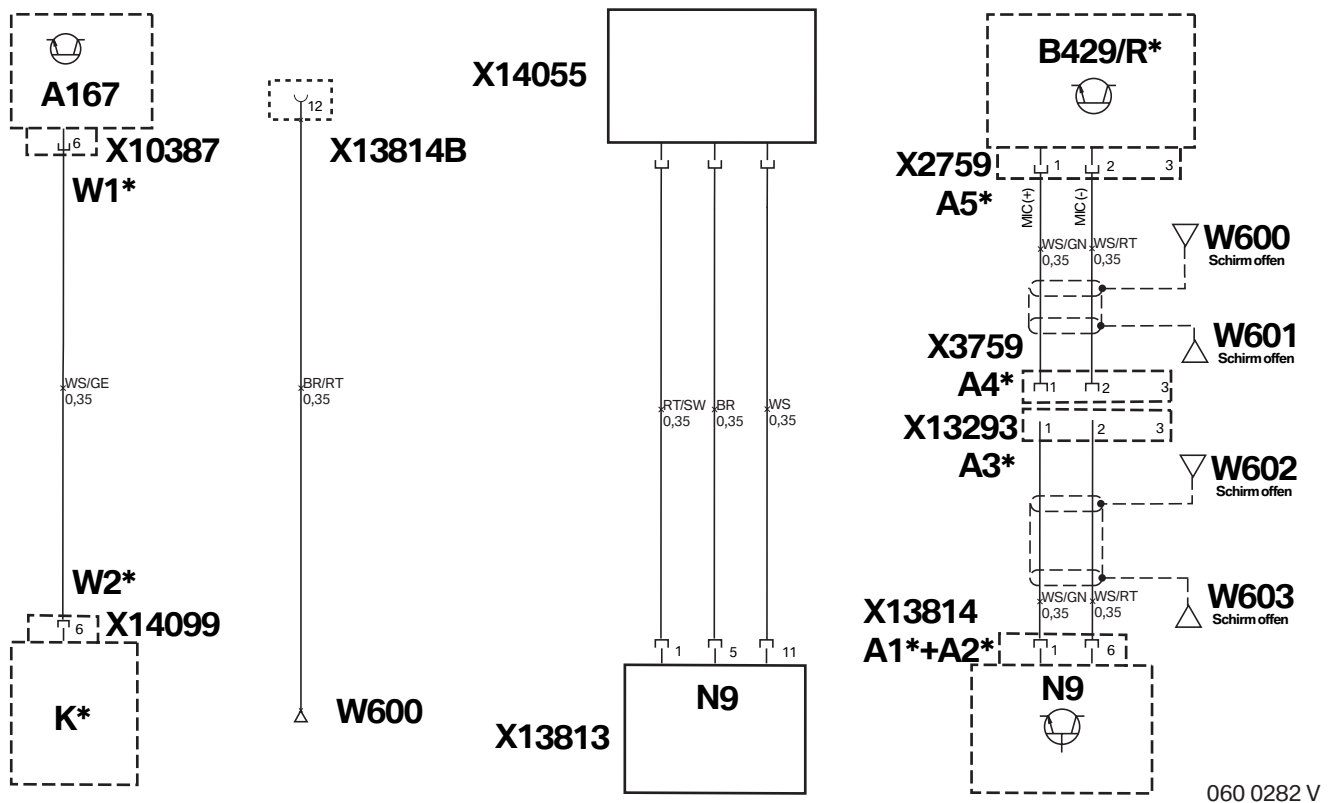

Legend

- A167** iDrive
- B429** Hands-free microphone **R***
- N9** Car Communication Computer (CCC)
- K*** Menu/voice input button

- X2759** 3-pin socket casing, SW, **A5***, to hands-free microphone **R***
- X3759** 3-pin socket casing, WS, **A4***, to 3-pin plug casing, WS, **A3***
- X10387** 8-pin SW socket casing, **W1***, to iDrive
- X13293** 3-pin plug casing, WS, **A3***, to 3-pin socket casing, WS, **A4***
- X13813** 12-pin socket casing, to Car Communication Computer
- X13814** 12-pin socket casing, WS, **A1*+A2***, to Car Communication Computer
- X14055** 3-pin socket casing, to CCC fan
- X14099** 4-pin SW socket casing, **W2***, to Menu/Voice input button **K***

- W600** Screen open
- W601** Screen open
- W602** Screen open
- W603** Screen open

All the designations marked with an asterisk (*) apply only to these installation instructions or this circuit diagram.

8. Circuit diagram

Cable colours

GN	Green
GE	Yellow
RT	Red
WS	White
BR	Brown
SW	Black