

Genuine BMW Accessories.

Installation Instructions.



NightVision retrofit BMW 5 Series Saloon (E60) BMW Series Touring (E61)

These installation instructions are only valid for cars with

-SA 502 (SRA) and SA 609 (Navigation Professional) from 03/05.

-SA 502 (SRA) and SA 601 (TV function) from 09/05.

Retrofit kit no.: 66 21 0 415 183 NightVision Camera retrofit kit

Installation time

The installation time is **approx. 6.5 hours**. This may vary depending on the condition of the car and the equipment in it.

Before starting the modification work, always flash the vehicle up to the latest I-level. Depending on the production age of the car and the work already carried out on it, the programming times will vary which means that we cannot quote a specific time for this. The installation time does not take the time taken for programming/encoding into account. This time depends on the age of the car and the equipment in it.

Important information

These installation instructions are primarily designed for use within the BMW dealership organisation and by authorised BMW service companies.

In any event, the target group for these installation instructions is specialist personnel trained on BMW cars with the appropriate specialist knowledge.

All work must be completed using the latest BMW repair manuals, circuit diagrams, servicing manuals and work instructions, in a rational order, using the prescribed tools (special tools) and observing current health and safety regulations.

If any installation or function problems occur, limit the troubleshooting session to approx. 0.5 hours for mechanical work or 1.0 hour for electrical work.

To avoid unnecessary extra work and/or costs, send a request immediately to Technical Support via the Aftersales Assistance Portal (ASAP).

At the same time, provide the following information:

- vehicle identification number,
- part number of the retrofit kit,
- precise description of the problem,
- operations already performed.

Do not archive the hard copy of these installation instructions since daily updates are made by ASAP!

All pictures show LHD cars; proceed accordingly on RHD cars.

Pictograms

 Denotes instructions that draw your attention to dangers.

 Denotes instructions that draw your attention to special features.

◀ Denotes the end of the instruction or other text.

Installation Information

Ensure that the cables/lines are not kinked or damaged as you install them in the car. Costs incurred as a result of this will not be reimbursed by BMW AG.

Additional cables/lines that you install must be secured with cable ties.

If the specified PIN chambers are occupied, bridges, double crimps or twin-lead terminals must be used.

Fuse link from connecting point **A26** must be attached and clearly visible on fuse carrier **A46** in the luggage compartment.

The two camera holders contained in the installation kit must be bolted together with the camera according to the year of manufacture.

Up to **03/07** BMW part number 6 962 500, from **03/07** BMW part number 6 986 459.

The two NightVision camera grill covers **F** contained in the installation kit must be installed, depending on the equipment.

Information for ordering parts

The lights control unit **C** is not included in the delivery specification and, depending on the equipment, must be ordered separately.

List of optional equipment

The following optional equipment must be taken into account in the assembly of the retrofit kit:

SA 601 **TV function**

SA 609 **Navigation system**

Special tools required

65 5 400 Release tool for navigation computer

Information for customers

The "Customer information" chapter at the end of the Installation Instructions must be printed out and handed over to the customer.

Contents

Section	Page
1. Parts overview.....	4
2. Preparatory work	5
3. Installation and cabling diagram	6
4. Overview of connections	7
5. Installing NightVision	9
6. Finishing off and encoding.....	16
7. Circuit diagram	17
8. Customer information	19

1. Parts overview

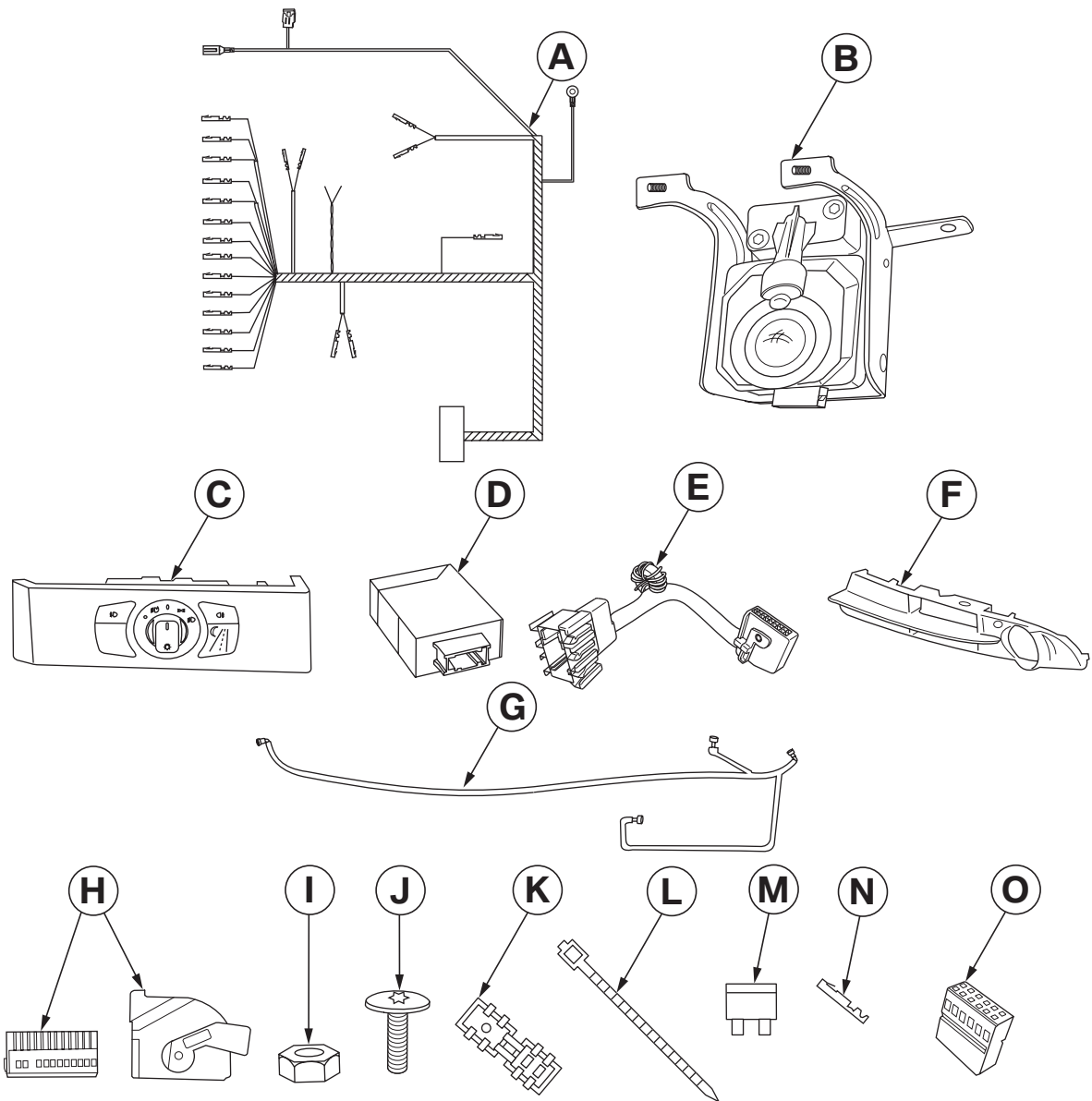

060 0179 E

Legend

- | | |
|--|---|
| A NightVision cable kit (1 piece) | I Hexagon nut (2 pieces) |
| B NightVision camera (1 piece) | J Torx bolt, M6 (1 piece) |
| C Lights control unit (1 piece) | K Miniconnectors (3 pieces) |
| D NightVision controller (1 piece) | L Cable clips (30 pieces) |
| E Adapter cable (1 piece) only with SA 601 | M Fuse, 10A (1 piece) |
| F Left grill (1 piece each) | N Bushing contact, Amp (1 piece) |
| G High pressure line (1 piece) | O Bushing housing, 12-pole (1 piece) |
| H Plug socket with housing (1 piece) | |

2. Preparatory work

	TIS No.
Perform quick test	—
Disconnect negative terminal of battery	12 00 ...
Dismantle the following components in advance	
Rear seat	52 24 005
Right glove compartment	51 16 367
Left air filter box	
Entrance strip, front left	51 47 000
Entrance strip, rear left	51 47 030
B-column trim, left	51 43 150
Rear seat back left, in vehicles with split rear seats	52 24 015
Lights control unit	61 31 037
Bumper trim, front	51 11 156
Panel trim, footwell on A-column, left	51 43 070
Panel, pedal	51 45 185
High pressure line SRA/NightVision camera	61 67 010
Navigation computer/CCC not with SA 601	65 90 511
Video module with SA 601	65 50 011
Remove and install left luggage compartment trim	51 47 210
Remove and install right luggage compartment trim	51 47 220
Remove and install the cover on the rear apron	51 46 050
Luggage compartment floor covering	51 47 101
Luggage compartment wheel housing, left	51 47 151

3. Installation and cabling diagram

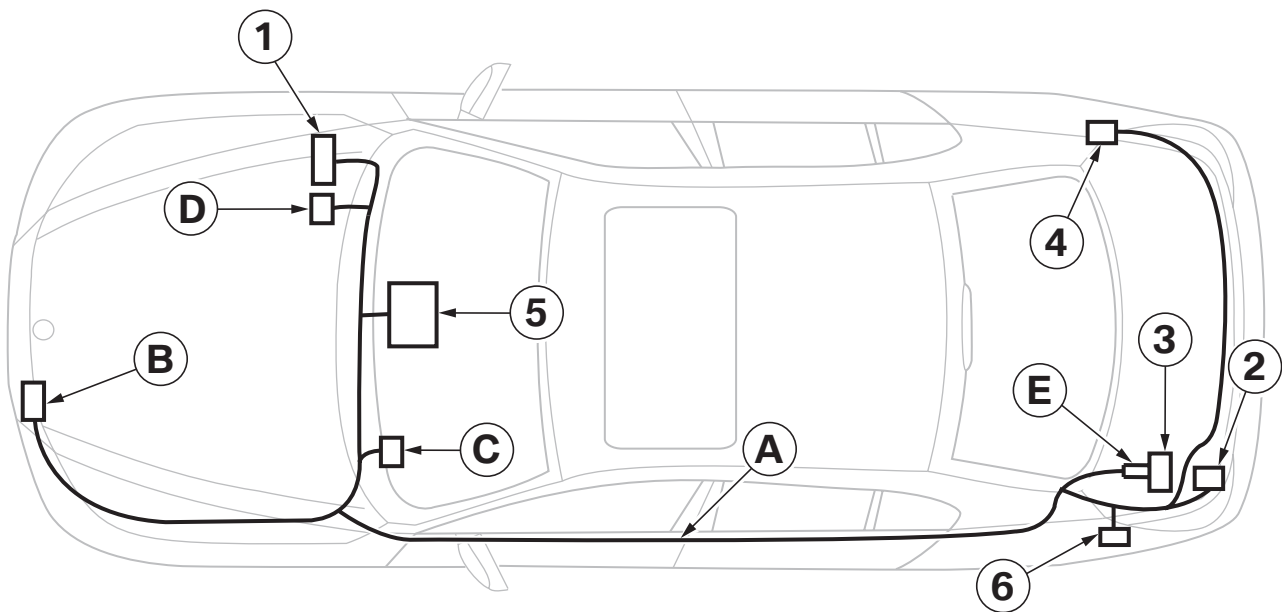

060 0180 E

Legend

A NightVision cable set

B NightVision camera assembly

C Lights control unit

D NightVision controller

E Cable adapter

1 SGM/KGM

2 Ground loom connector **X13793**

3 Video module

4 Fuse carrier **X11011/X11012**

5 Navigation computer/CCC

6 Ground loom connector **X13016**

4. Overview of connections

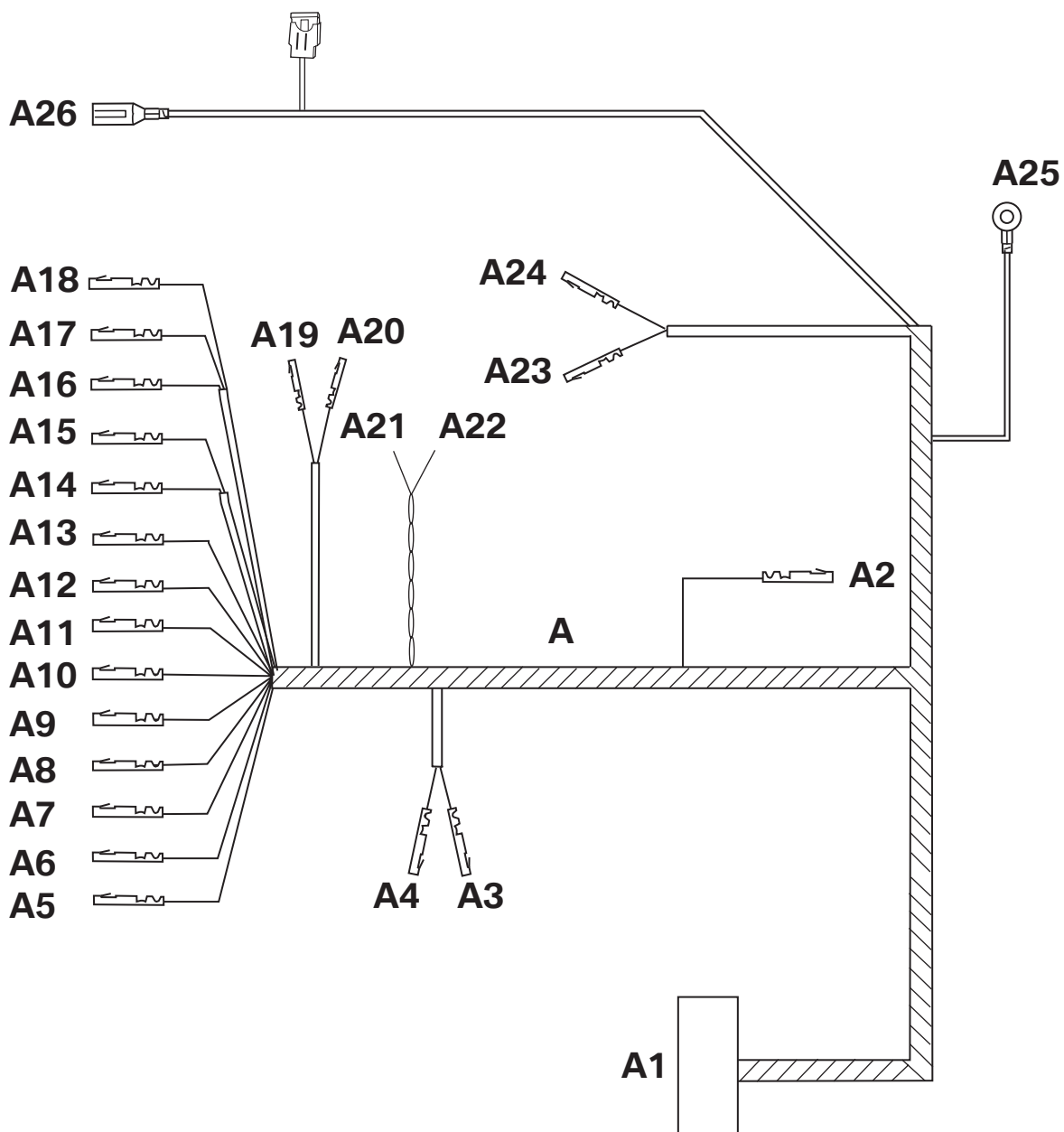

060 0181 E

Item	Description	Signal	Wire colour / cross section	Connection location in vehicle	Designation/plug-in location
A	NightVision cable set				
A1	Bushing housing, 12-pole, SW			On NightVision camera	X16665
A2	Female contact	S-NiVi	BL 0.35 mm ²	On lights control unit S8	X13339 PIN 6
A3	Female contact	Screen	TR 0.35 mm ²	Without SA 601 , on navigation computer N38 , bushing housing O , WS, 12-pole	X13814 PIN 2
A4	Female contact	FBAS	SW 0.35 mm ²	Without SA 601 , on navigation computer N38 , bushing housing O , WS, 12-pole	X13814 PIN 4

Item	Description	Signal	Wire colour / cross section	Connection location in vehicle	Designation/plug-in location
A5	Female contact	Lin_Signal	VI 0.35 mm ²	On NightVision controller A859 , on bushing housing H , SW, 18-pole	X16664 PIN 12
A6	Female contact	Lin_bus	BR/GE 0.35 mm ²	On NightVision controller A859 , on bushing housing H , SW, 18-pole	X16664 PIN 13
A7	Female contact	S_NightVision	BL 0.35 mm ²	On NightVision controller A859 , on bushing housing H , SW, 18-pole	X16664 PIN 3
A8	Female contact	Terminal 31	SW/BR 0.35 mm ²	On NightVision controller A859 , on bushing housing H , SW, 18-pole	X16664 PIN 17
A9	Female contact	Terminal 31	BR 0.75 mm ²	On NightVision controller A859 , on bushing housing H , SW, 18-pole	X16664 PIN 14
A10	Female contact	Cam-power	RT/BL 0.35 mm ²	On NightVision controller A859 , on bushing housing H , SW, 18-pole	X16664 PIN 16
A11	Female contact	CAN-high	GN/OR 0.5 mm ²	On NightVision controller A859 , on bushing housing H , SW, 18-pole	X16664 PIN 10
A12	Female contact	CAN-low	GN 0.5 mm ²	On NightVision controller A859 , on bushing housing H , SW, 18-pole	X16664 PIN 1
A13	Female contact	30g	RT/GN 0.75 mm ²	On NightVision controller A859 , on bushing housing H , SW, 18-pole	X16664 PIN 5
A14	Female contact	Screen	TR 0.35 mm ²	Without SA 601 , on control unit NightVision A859 , on bushing housing H , SW, 18-pole	X16664 PIN 18
A15	Female contact	FBAS	SW 0.35 mm ²	Without SA 601 , on control unit NightVision A859 , on bushing housing H , SW, 18-pole	X16664 PIN 9
A16	Female contact	Video GND	SW 0.35 mm ²	On NightVision controller A859 , on bushing housing H , SW, 18-pole	X16664 PIN 7
A17	Female contact	Video	GE 0.35 mm ²	On NightVision controller A859 , on bushing housing H , SW, 18-pole	X16664 PIN 6
A18	Female contact	Screen	TR 0.35 mm ²	On NightVision controller A859 , on bushing housing H , SW, 18-pole	X16664 PIN 15
A19	Female contact	Screen	TR 0.35 mm ²	Only with SA 601 , on bushing housing H , SW, 18-pole	X16664 PIN 18
A20	Female contact	FBAS	SW 0.35 mm ²	Only with SA 601 , on bushing housing H , SW, 18-pole	X16664 PIN 9
A21	Open end of wire	CAN-low	GN 0.5 mm ²	Up to 09/05 , on SGM A220 , bushing housing, BR, 52-pole with miniconnector From 09/05 , on KGM A16760 , bushing housing, SW, 51-pole with miniconnector	X13581 PIN 36 X16760 PIN 8
A22	Open end of wire	CAN-high	GN/OR 0.5 mm ²	Up to 09/05 , on SGM A220 , bushing housing, BR, 52-pole with miniconnector From 09/05 , on KGM A16760 , bushing housing, SW, 51-pole with miniconnector	X13581 PIN 35 X16760 PIN 9
A23	Female contact	Screen	TR 0.35 mm ²	Only with SA 601 , from video module A197, bushing housing, WS, 18-pole	X18804 PIN 10
A24	Female contact	FBAS	SW 0.35 mm ²	Only with SA 601 , from video module A197, bushing housing, WS, 18-pole	X18804 PIN 1
A25	Eye ring	Terminal 31	BR 0.75 mm ²	On ground loom connector, luggage compartment, left On ground loom connector, luggage compartment, left	X13793 / E60 X13016 / E61
A26	Flat male connector	30g	RT/GN 0.75 mm ²	Up to 09/05 , on fuse carrier A46 , bushing housing, WS, 10-pole Luggage compartment right, fuse 87 From 09/05 , on fuse carrier A46 , bushing housing, SW, 41-pole Luggage compartment right, fuse 80	X11011 PIN 5 X11012 PIN 32

5. Installing NightVision

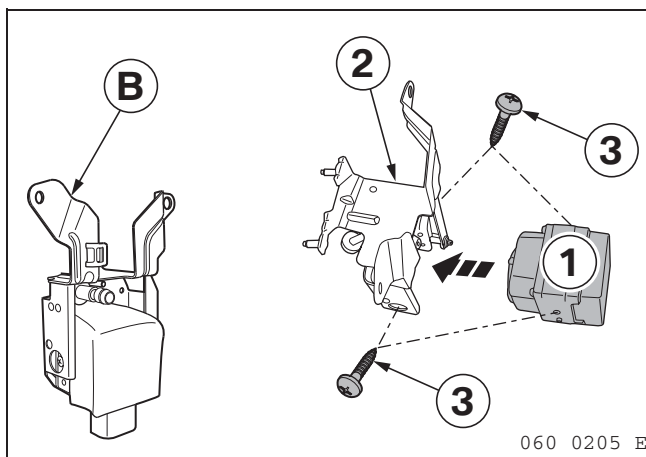

Assemble NightVision camera **B** as follows:

- Insert the camera (1) into the metal bracket (2).
- Screw the camera (1) onto the holder (2) with lens head screws (3).

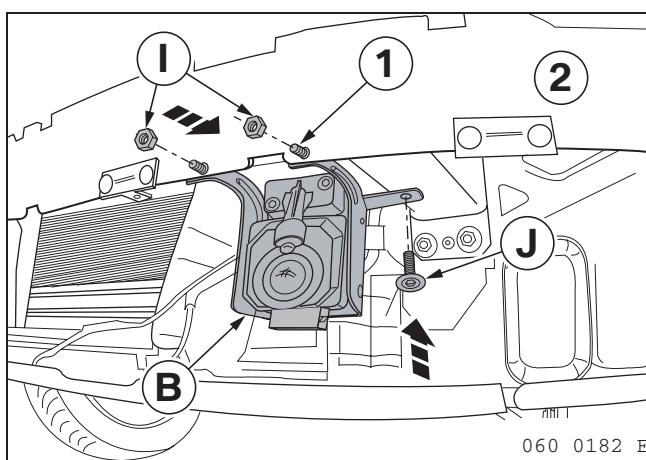

▶ Aluminium mounting of front bumper. ◀

Insert the stud (1) of assembly camera **B** into the existing bore holes of the aluminium mounting (2) from the rear.

Mount camera **B** on the aluminium mounting (2) with nuts **I** and bolt **J**.

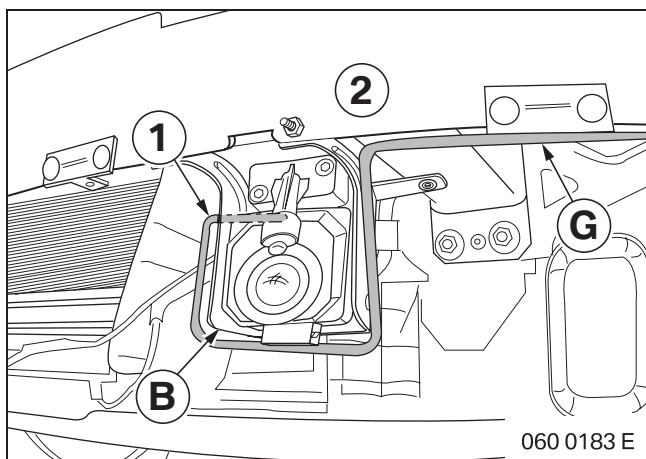

Install high pressure line **G** according to **TIS 61 67 010**.

Route the branch (1) of line **G** to camera **B** beneath the aluminium mounting (2).

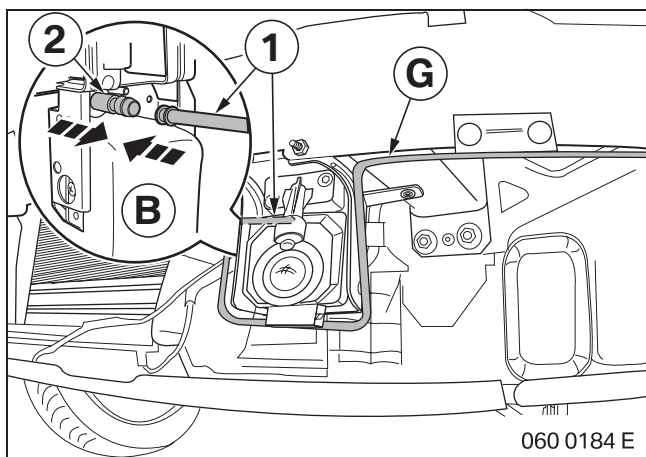

Connect the branch (1) of line **G** to the injection nozzle (2) of camera **B** from the rear.

5. Installing NightVision

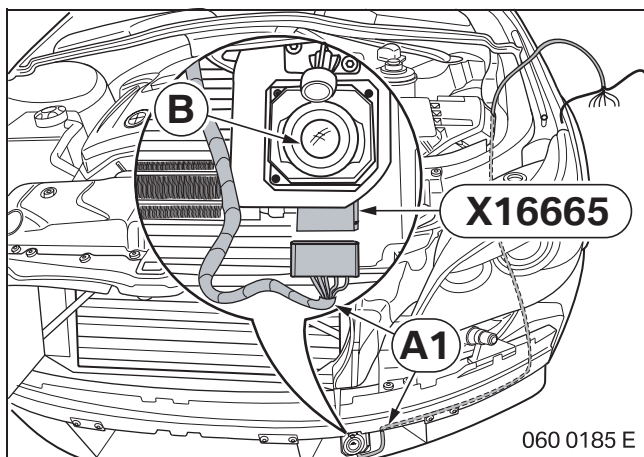

Route connecting point **A1** to camera **B** along the vehicle wiring harness.

Connect connecting point **A1** to connection **X16665** of camera **B**.

When installing the front bumper, insert grill left **F** into the front bumper (not shown).

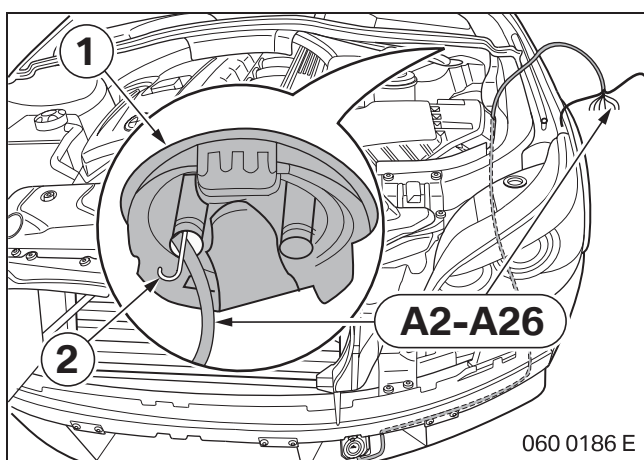

Pull connecting points **A2** to **A26** into the car interior through the rubber grommet (1).

Use the draw-in tool (2).

Correctly seal the rubber grommet (1) using Sikaflex.

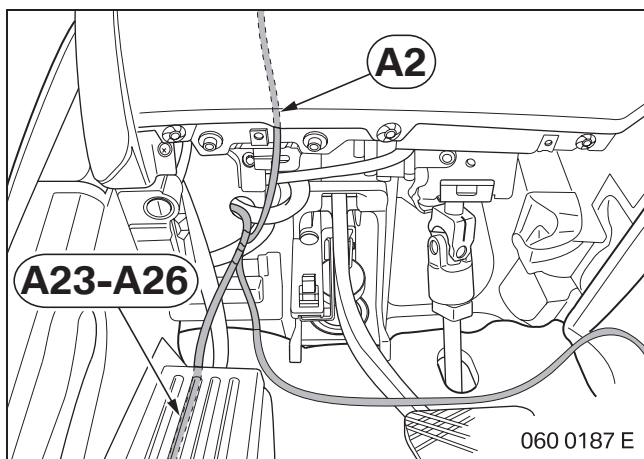

Route the connecting points as follows:

- Connecting points **A23** to **A26** in luggage compartment, left.
- Connecting point **A2** to the lights control unit.

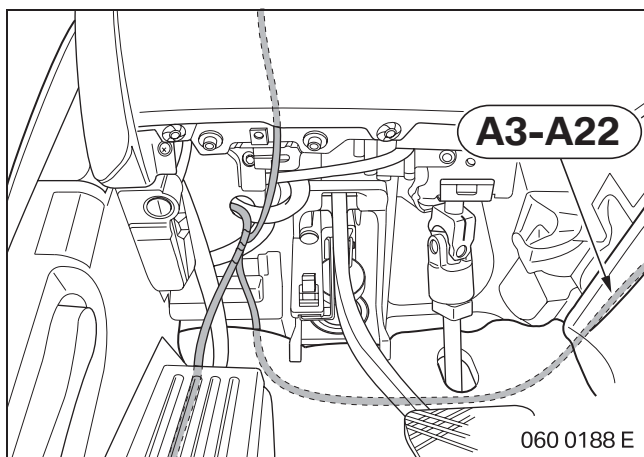

Route connecting points **A3** to **A22** behind the heater to the fuse carrier in the glove box.

5. Installing NightVision

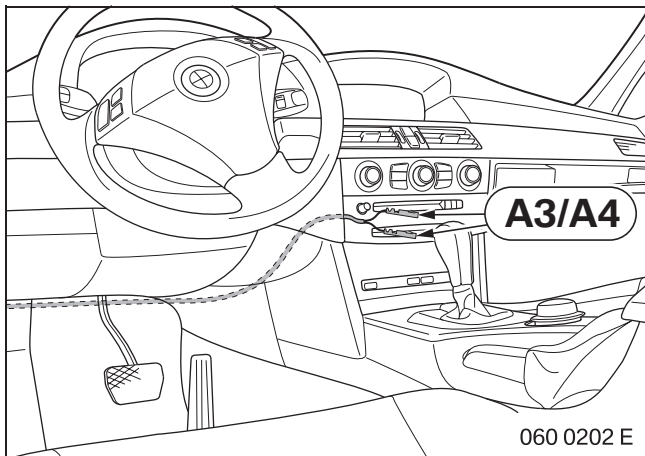

060 0202 E

Only for cars without SA 601.

Route connecting points **A3** and **A4** to the navigation computer in the centre console.

Only for cars with SA 601.

Insulate and tie back connecting points **A3** and **A4**.

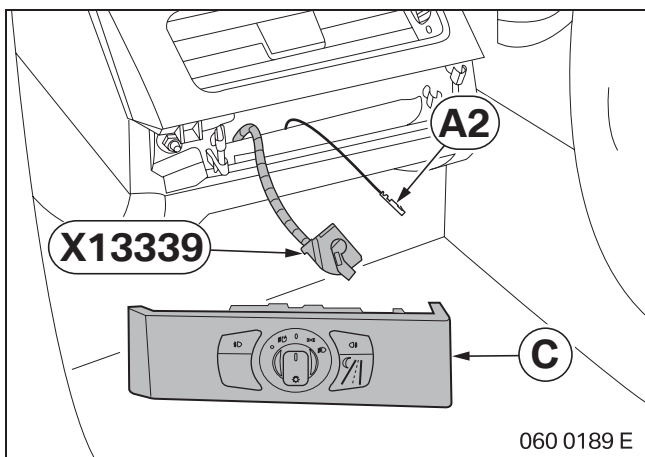

060 0189 E

For all vehicles.

Pin connecting point **A2**, BL, into connector **X13339**, PIN 6.

Install lights control unit **C**.

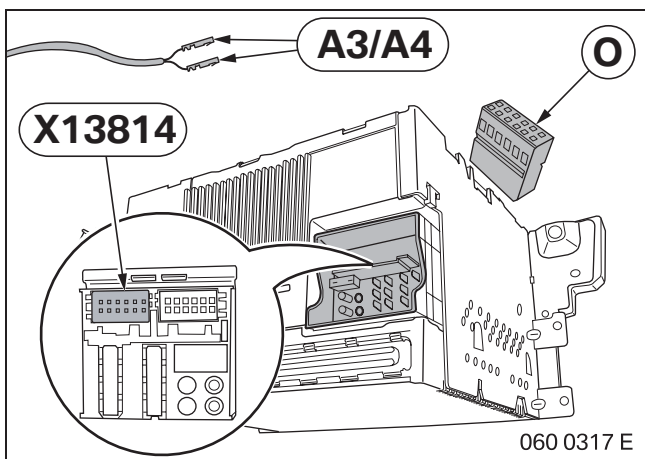

060 0317 E

Only for cars without SA 601.

Pin the connecting points as follows onto the navigation computer in **X13814**, 12-pole, WS:

A3, TR, in PIN 2.

A4, SW, in PIN 4.

If bushing link **X13814** is not connected, use bushing housing **O**.

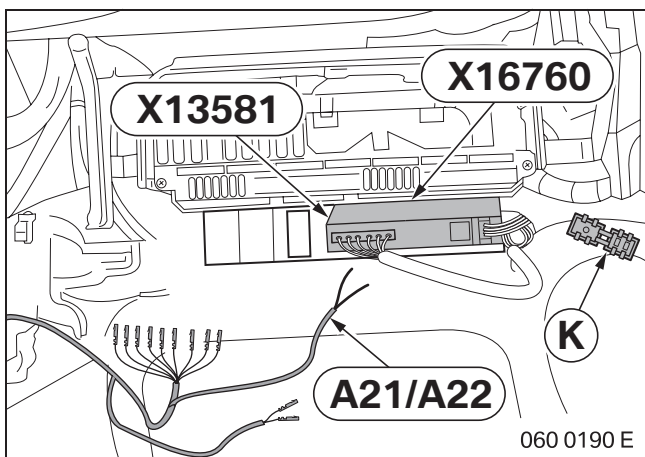

060 0190 E

Only for cars before 09/05.

In the front passenger footwell, connect connecting points on SGM **X13581** with miniconnector **K** as follows:

A21, GN, to PIN 36, GE.

A22, GNOR, to PIN 35, SW.

Only for cars from 09/05.

Connect connecting points on KGM **X16760**:

A21, GN, to PIN 8, GE.

A22, GNOR, to PIN 9, SW.

5. Installing NightVision

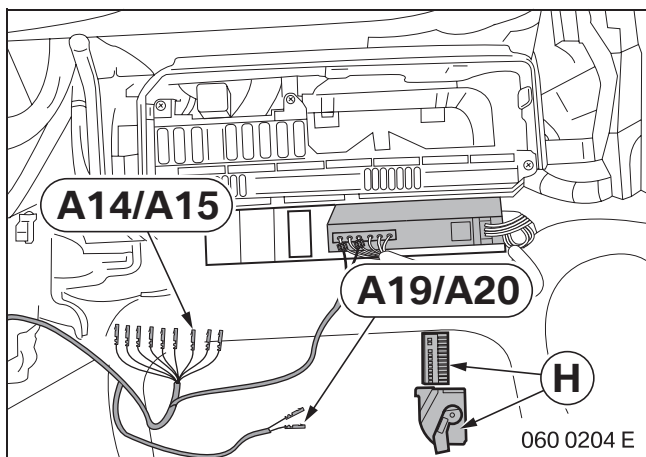

Only for cars without SA 601.

Pin connecting points in bushing housing **H** as follows:

A14, TR, in PIN 18.

A15, SW, in PIN 9.

Insulate and tie back connecting points **A19** and **A20**.

Only for cars with SA 601.

A19, TR, in PIN 18.

A20, SW, in PIN 9.

Insulate and tie back connecting points **A14** and **A15**.

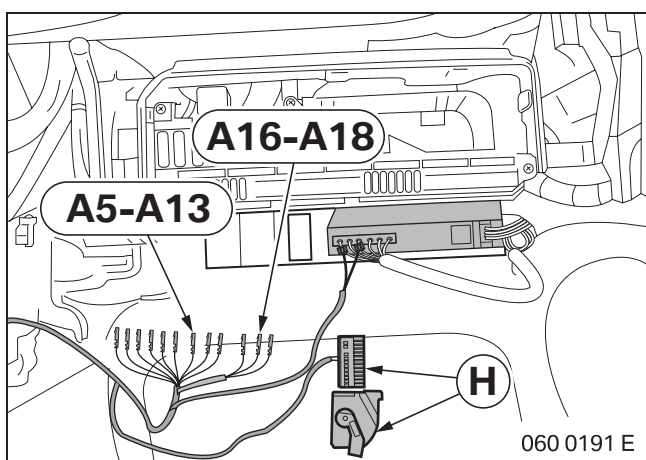

For all vehicles.

Pin connecting points in bushing housing **H** as follows:

A5, VI, in PIN 12.

A6, BRGE, in PIN 13.

A7, BL, in PIN 3.

A8, SWBR, in PIN 17.

A9, BR, in PIN 14.

A10, RTBL, in PIN 16.

A11, GNOR, in PIN 10.

A12, GN, in PIN 1.

A13, RTGN, in PIN 5.

A16, SW, in PIN 7.

A17, GE, in PIN 6.

A18, TR, in PIN 15.

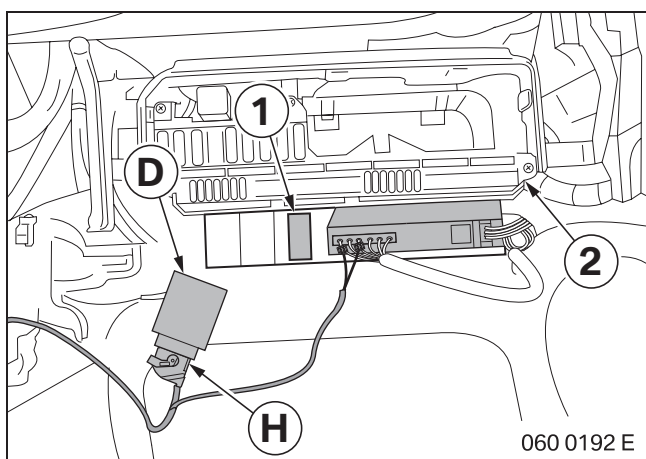

Insert plug housing **H** into controller **D**.

Push controller **D** into free slot in the device carrier (1) behind the fuse carrier (2).

5. Installing NightVision

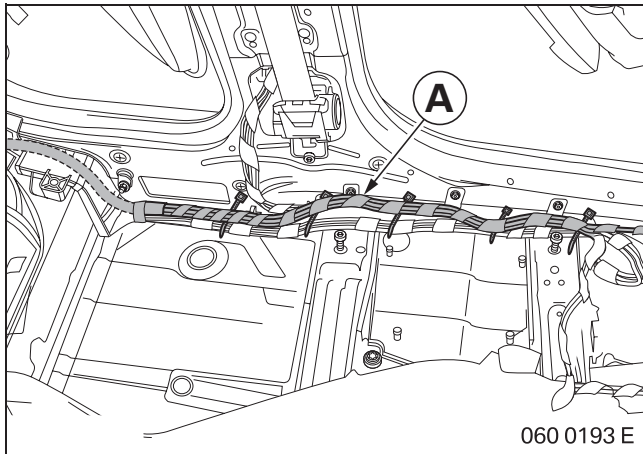

Route cable kit **A** along the vehicle wiring harness on the vehicle floor.

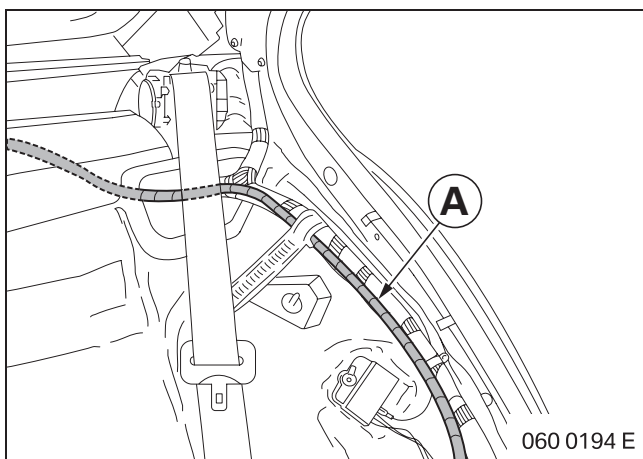

Route cable kit **A** along the C-pillar in the luggage compartment.

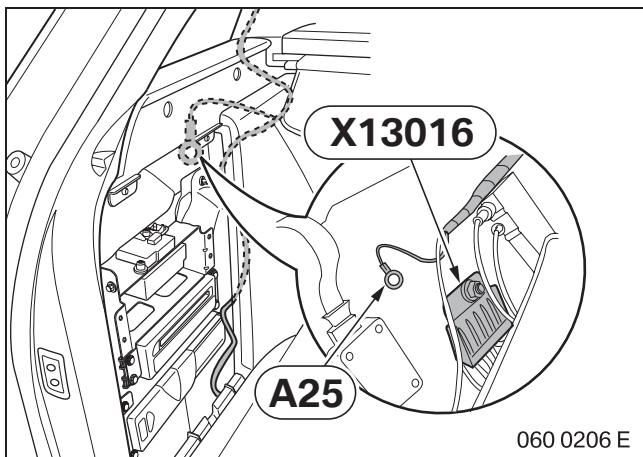

Only for E61 (Touring).

In the luggage compartment on the left, screw connecting point **A25**, BR, onto ground loom connector **X13016**.

5. Installing NightVision

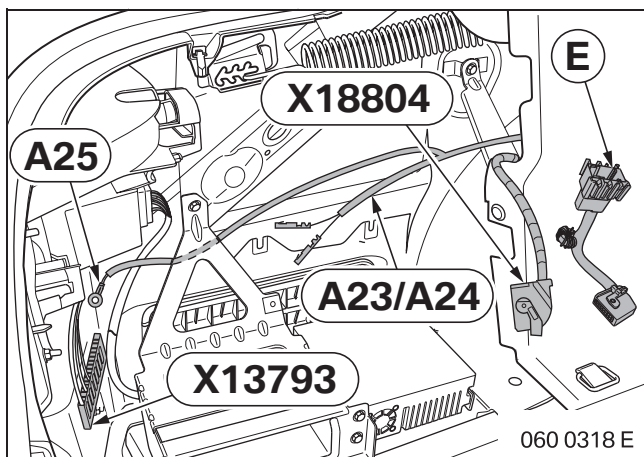

Only for E60 (Saloon).

Screw **A25**, BR, onto ground loom connector **X13793**.

Only for cars without SA 601.

Insulate and tie back connecting points **A23** and **A24** in luggage compartment, left.

Only for cars with SA 601.

Pin the connecting points as follows into the connector of video module **X18804**, WS:

A23, TR, in PIN 10.

A24, SW, in PIN 1.

▶ If **X18804** is not installed, the 18-pole socket housing, WS, is removed from cable adapter **E** and used. The rest of adapter **E** is no longer needed. ◀

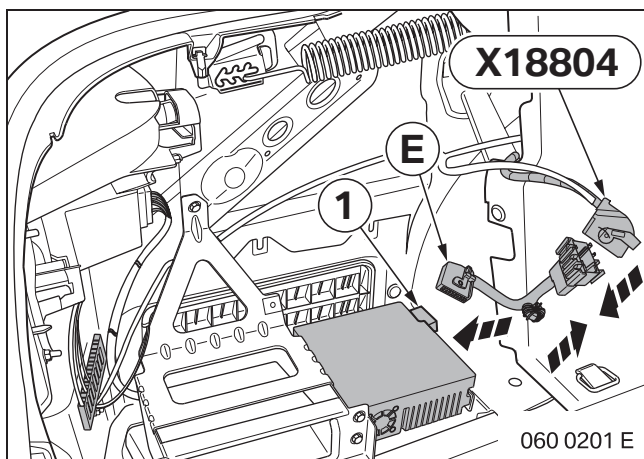

Connect cable adapter **E** between **X18804** and the video module (1).

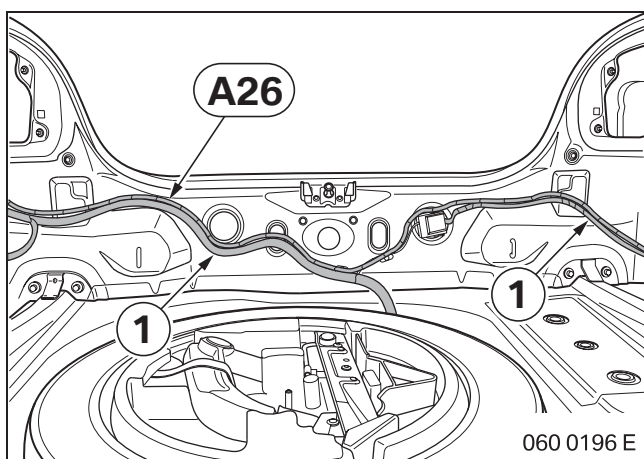

For all vehicles.

Route connecting point **A26** along the vehicle wiring harness (1) on the rear panel to the fuse carrier on the right.

5. Installing NightVision

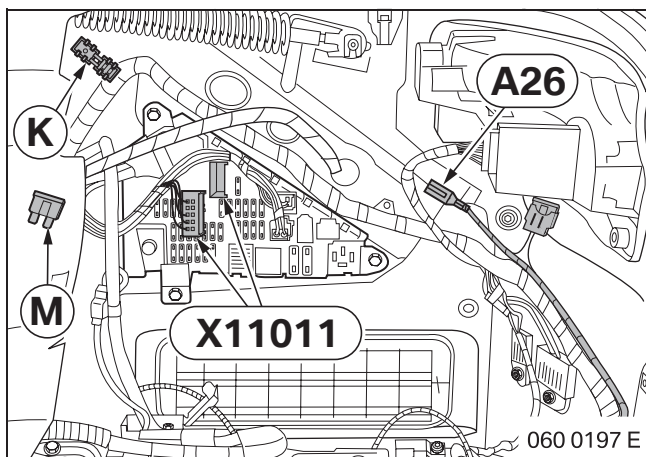

Only for cars before 09/05.

In the luggage compartment right, connect the pins as follows:

- Connect connecting point **A26**, RTGN, to 10-pole bushing housing, WS, **X11011**, PIN 5.
- If PIN 5 is occupied, separate the bushing contact from connecting point **A26** and attach the parallel stop with miniconnector **K** to **X11011**, PIN 5.

 Insert fuse 10A **M** into slot 87.

If slot 87 is already fused with more than 10A, fuse **M** is not needed.

If slot 87 is fused with less than 10A, it must be replaced with fuse **M**. ◀

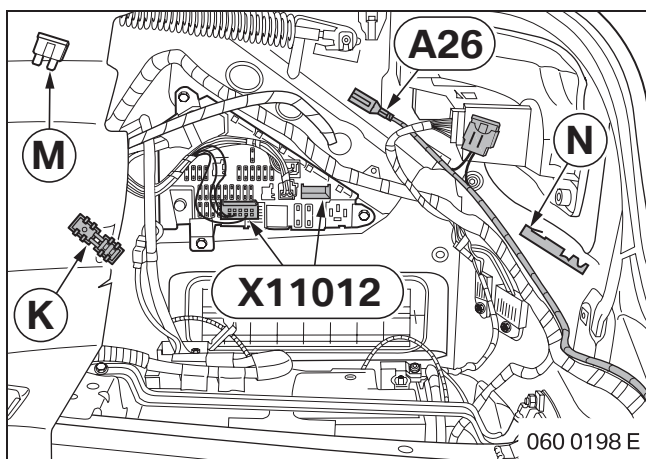

Only for cars from 09/05.

Connect the pins on the fuse carrier as follows:

- Separate the bushing contact from connecting point **A26**, RTGN.
- Crimp on bushing contact **N** and plug into 41-pole bushing housing **X11012**, SW, PIN 32.

If PIN 32 is occupied, attach the parallel stop with miniconnector **K** to **X11012**, PIN 32.

 Insert fuse 10A **M** into slot 80.

If slot 80 is already fused with more than 10A, fuse **M** is not needed.

If slot 80 is fused with less than 10A, it must be replaced with fuse **M**. ◀

6. Finishing off and encoding

- Connect the vehicle battery.
- Code/program retrofit with DISPlus or GT-1 via path **Retrofit/CIP**.
- Adjust the camera axially and vertically as described in the repair manual.
- Perform a short test.
- Perform a function test.
- Reassemble the vehicle analogously.

7. Circuit diagram

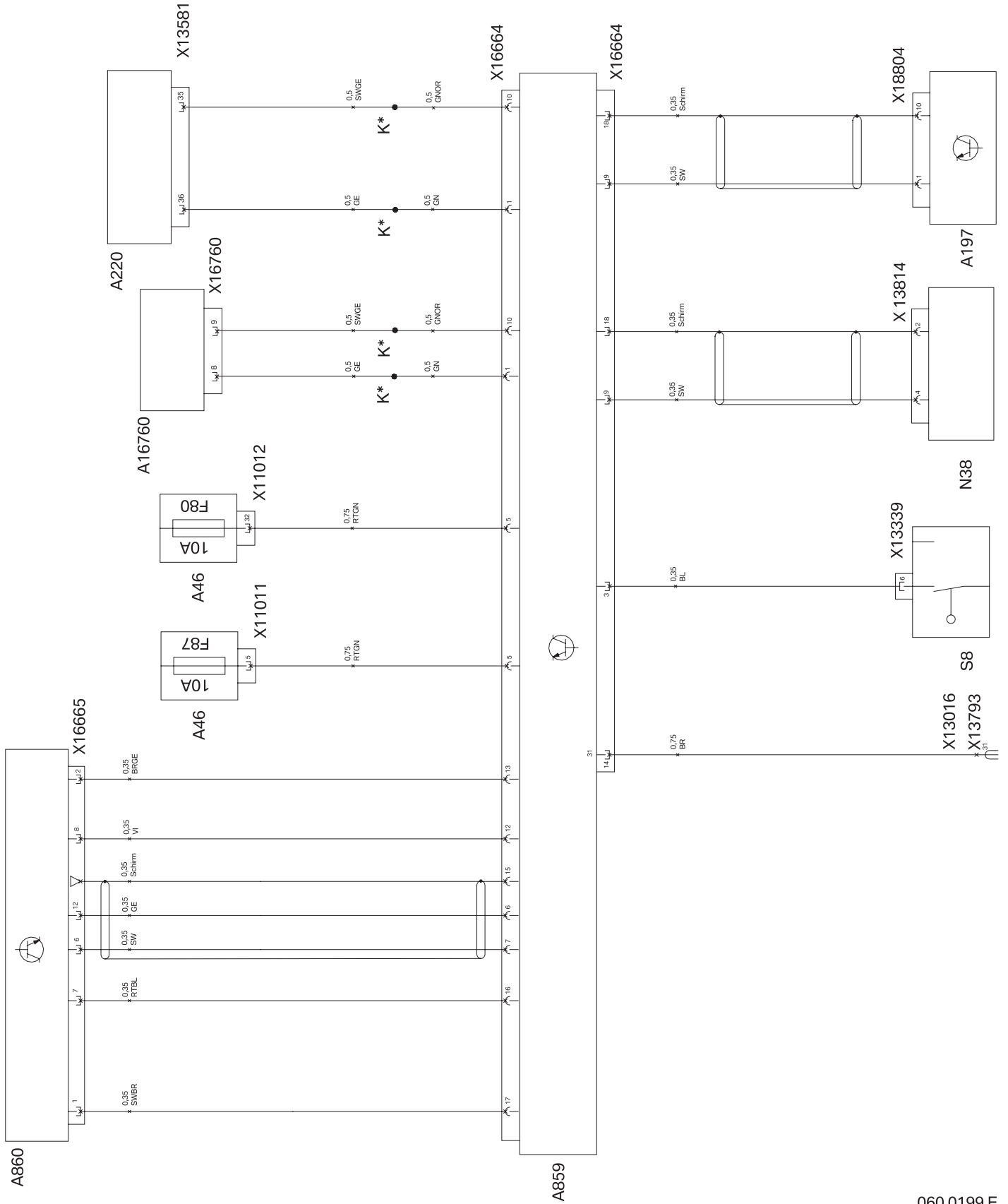

060 0199 E

7. Circuit diagram

Key

A46	Fuse carrier, luggage compartment, right
A197	Video module
A220	SGM
A859	Controller, NightVision
A860	Camera, NightVision
A16760	KGM
K*	Miniconnector
N38	Navigation computer
S8	Lights control unit
X11011	Bushing housing, 10-pole, white, on fuse carrier in luggage compartment, before 09/05
X11012	Bushing housing, 41-pole, black, on fuse carrier in luggage compartment, from 09/05
X13016	Ground loom connector, luggage compartment, left (E61, Touring)
X13339	Plug socket, 18-pole, black, on lights operating control
X13581	Bushing housing, 52-pole, brown, on SGM
X13793	Ground loom connector, luggage compartment, left (E60, Saloon)
X13814	Plug housing, 12-pole, white, on navigation computer CCC
X16664	Plug socket, 18-pole, black, on NightVision control unit
X16665	Plug socket, 12-pole, black, on NightVision camera
X16760	Bushing housing, 51-pole, black, on KGM
X18804	Bushing housing, 18-pole, white, on video module

All designations marked with an * apply only to these installation instructions or this circuit diagram.

Caution! Video module **A197** or navigation computer **N38** is optionally connected depending on the equipment specifications in the car.
Connections are made on fuse carriers **A46** and **SGM/KGM** according to the year of construction of the model.

Cable colours

RT	Red
BR	Brown
WS	White
BL	Blue
VI	Violet
GE	Yellow
SW	Black
BL	Blue
GN	Green
OR	Orange

8. Customer information

Conditions required for switching on NightVision

For NightVision to function, one of the following basic conditions is required:

- The rain driving light sensor detects sufficient ambient light and the driving light is switched off:
The BMW NightVision is operational approx. 2 seconds after the button (1) in the light switch centre (2) is pressed. A message is shown on the Multi Information Display (MID) during these two seconds.
- The rain driving light sensor detects insufficient ambient light and the driving light is switched on:
The BMW NightVision is immediately operational after the button (1) is pressed.
- In darkness (underground car park), the driving light is switched off and the car's road speed is less than 5 km/h:
The BMW NightVision is operational after the button (1) in the light switch centre (2) is pressed.

For safety reasons, the NightVision feature is **not** possible while driving (at speeds greater than 5 km/h) in darkness without the driving light.

In this case, a message appears on the MID that informs the driver that the system cannot be used at night.

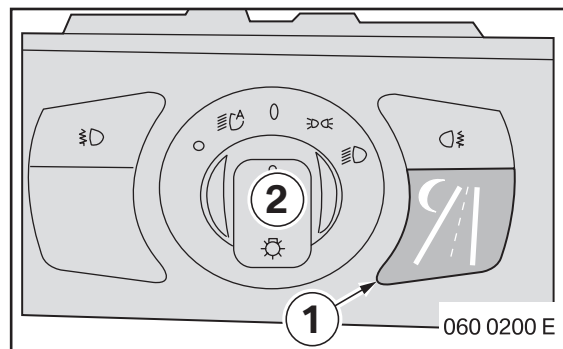

Operation via iDrive

Via iDrive, the individual iDrive functions and settings can be selected and activated.

 Please refer to the extensive description of how to operate BMW NightVision in the BMW operating instructions. ◀

 In any case, always adapt the car's driving speed to the respective visibility conditions. BMW NightVision is designed as a support system, providing an earlier and clearer view of the situation in front of the vehicle for drivers who operate the vehicle in a manner suitable to road conditions. ◀

Fusing

The BMW NightVision is fused with a 10A inline fuse in the fuse carrier in the luggage compartment.

For cars before 09/05:

In addition, BMW NightVision is fused in slot 87 of the fuse carrier in the luggage compartment.

For cars from 09/05:

In addition, BMW NightVision is fused in slot 80 of the fuse carrier in the luggage compartment.