



Parts and Accessories. Installation Instructions.

Professional Car Phone Upgrade BMW 5 Series (E60)

These installation instructions are only valid for cars with SA 640 (telephone preparation).

Upgrade kit No. 84 64 0 303 121

Installation time

The installation time is approx 3.5 – 4.0 hours, but this may vary depending on the condition of the car and the equipment in it.

Important information

These installation instructions are primarily designed for use within the BMW dealership organisation and by authorised BMW service companies.

In any event the target group for these installation instructions is specialist personnel trained on BMW cars with the appropriate specialist knowledge.

All work must be completed using the latest BMW repair manuals, circuit diagrams, servicing manuals and work instructions in a rational order using the prescribed tools (special tools) and observing current health and safety regulations.

Ensure that the cables/lines are not kinked or damaged as you install them in the car. The costs incurred as a result of this will not be reimbursed by BMW AG.

Additional cables/lines that you install must be secured with cable ties.

If the specified PIN chambers are occupied, bridges, double crimps or twin-lead terminals must be used.

Before you install the retrofit system, test the control module status with the CIP (coding, customising, programming) test program. If the test detects incorrect statuses in one or more control modules, these must be updated first using the “Load software” function.

All the figures show LHD cars, proceed accordingly on RHD cars.

Pictograms:



denotes instructions that draw your attention to dangers.



denotes instructions that draw your attention to special features.

◀ denotes the end of the instruction or caution text.

See the EBA CD or Aftersales Portal for explanations of the pictograms.

Do not archive the hard copy of these installation instructions since daily updates are made by Aftersales Portal.

Subject to technical modifications.

Installation information

Some of the installation is shown only on the left-hand side of the car, proceed in the same way on the right-hand side of the car.

When routing fibre optic cables, make sure the bending radius is no less than 25 mm.

After the installation work the retrofit kit must be programmed / coded using DISPlus or GT-1 via the **Retrofit** path.

Ordering instructions

All parts in other colours are not part of the upgrade kit and must be ordered separately (see EPC for part number and documentation).

List of special equipment

The following special equipment must be taken into consideration when installing the upgrade kit:

SA 403 Glass roof

Special tools required

None

Contents

| Section | Page |
|--|------|
| 1. Parts list | 4 |
| 2. Preparations..... | 6 |
| 3. Installation and cabling diagram | 7 |
| 4. To connect the fibre optic cable | 8 |
| 5. To install and connect the telematics control unit | 9 |
| 6. To install and connect the aerials | 12 |
| 7. To install and connect the eject box..... | 13 |
| 8. To install and connect the emergency call button and microphones..... | 15 |
| 9. Concluding work and coding | 17 |

1. Parts list

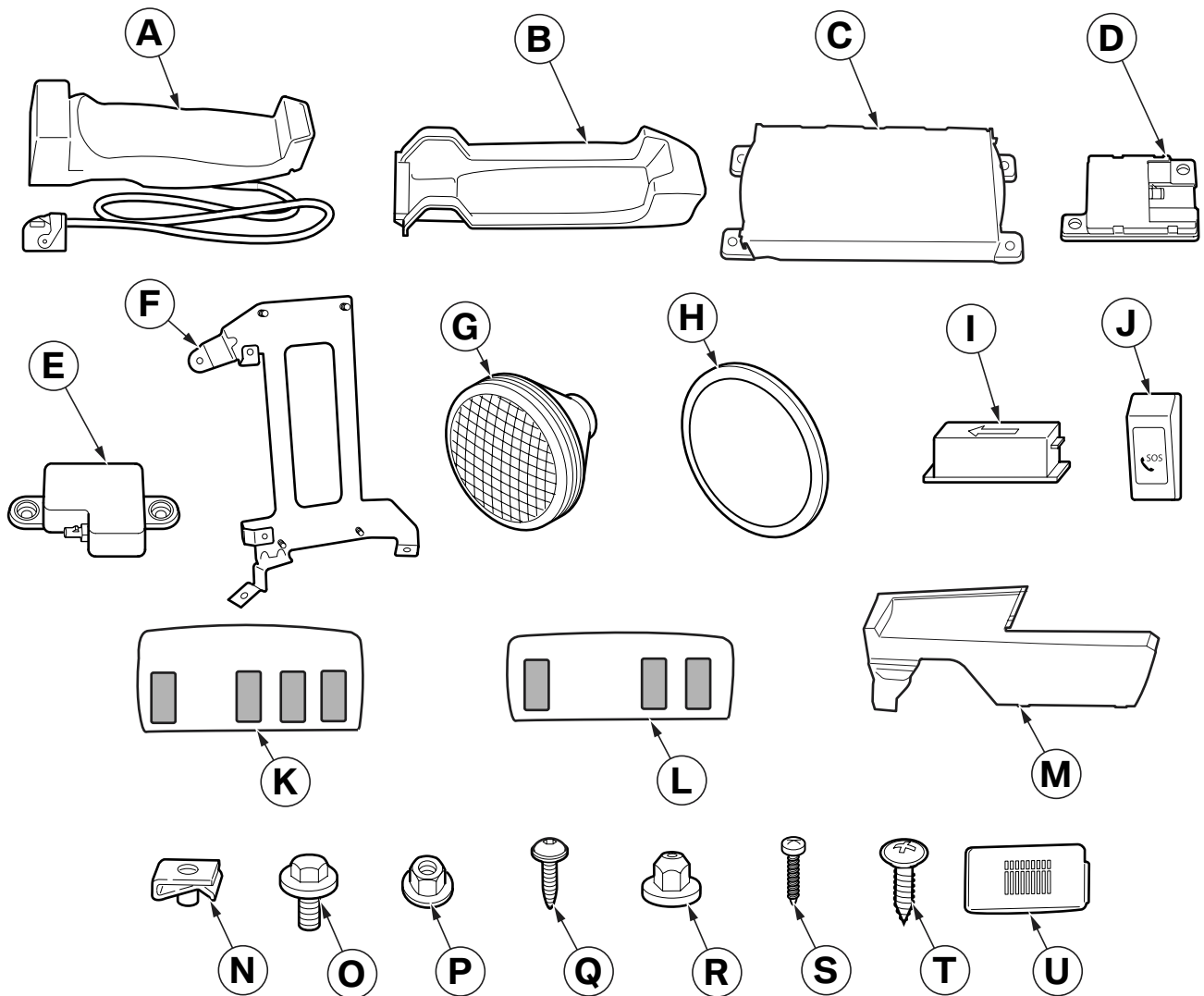

060 0069 Z

Legend

- A Eject box
- B Telephone mounting
- C Telematics control unit (TCU)
- D Bluetooth aerial
- E Back-up aerial (not installed for the moment)
- F Holder
- G Speaker (not installed for the moment)
- H Threaded ring (not installed for the moment)
- I Microphone (2x)
- J Emergency call button

1. Parts list

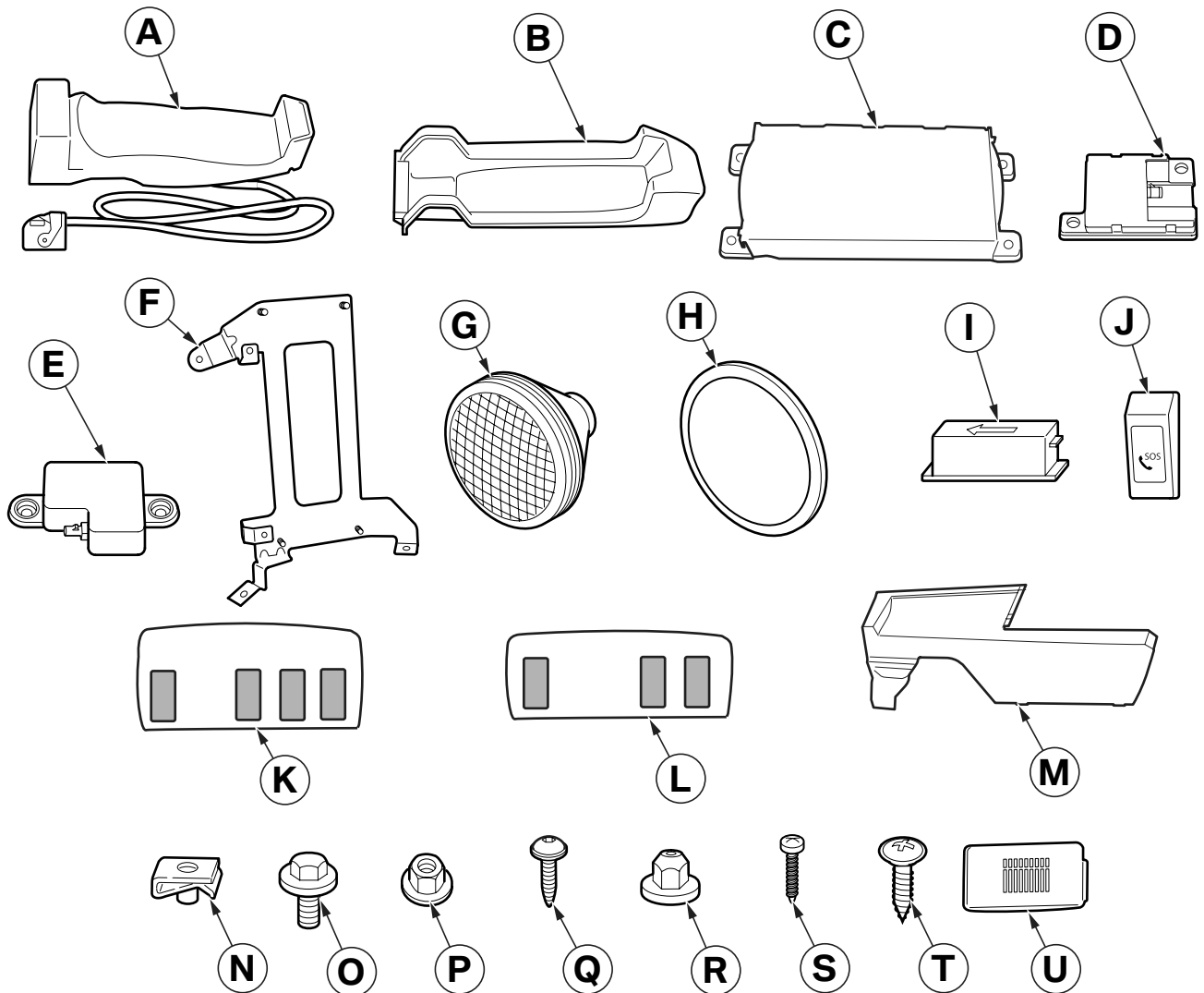

060 0069 Z

Legend

- K Headlining trim with SA 403 (not included in kit)
- L Headlining trim without SA 403 (not included in kit)
- M Centre armrest cover (not included in kit)
- N Speed nut
- O Hexagonal screw M5 x 14 mm (3x)
- P Hexagonal nut M5 (4x)
- Q Self-tapping screw M5 x 12 mm (2x) (not installed for the moment)
- R Cap nut M5 (2x) (cars up to 09/03 only)
- S Fillister head screws (4x)
- T Self-tapping screw 4.8 x 13 mm (2x) (cars from 09/03 only)
- U Microphone trim (2x) (not included in kit)

2. Preparations

| | TIS No. |
|---|-----------|
| Conduct a brief test | --- |
| Disconnect the negative pole of the battery | 12 00 ... |
| The following components must be removed first of all | |
| Front ceiling light | 63 31 000 |
| Centre armrest oddments tray | 51 ... |
| Centre console (cars from 09/03 only) | 51 ... |
| Fresh air grille in the rear | 64 22 191 |
| Fold down backrest | --- |
| Backrest side section on the rear seat backrest, left and right | 52 26 008 |
| Trim for rear window shelf (cars up to 09/03 only) | 51 46 001 |
| Luggage compartment side trim left | 51 ... |

3. Installation and cabling diagram

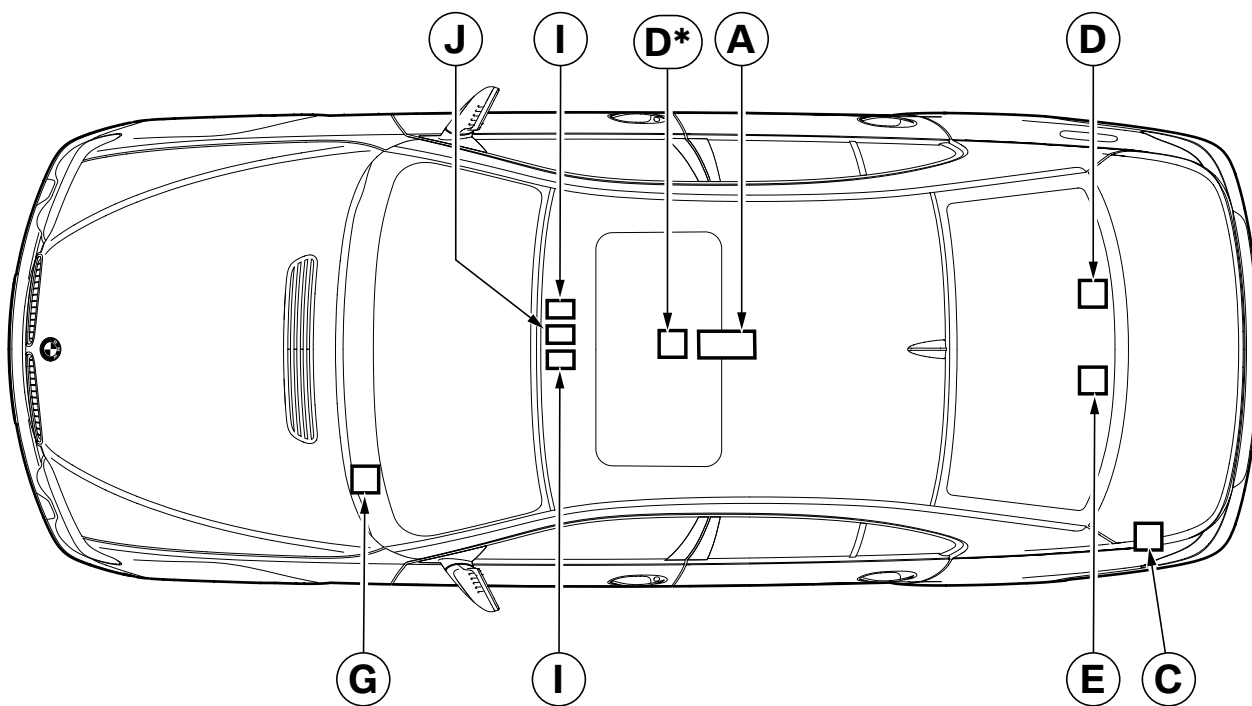

060 0070 Z

Legend

- A Eject box
- C Telematics control unit (TCU)
- D Bluetooth aerial (cars up to 09/03 only)
- D* Bluetooth aerial (cars from 09/03 only)
- E Back-up aerial (not installed for the moment)
- G Speaker (not installed for the moment)
- I Microphones
- J Emergency call button

4. To connect the fibre optic cable

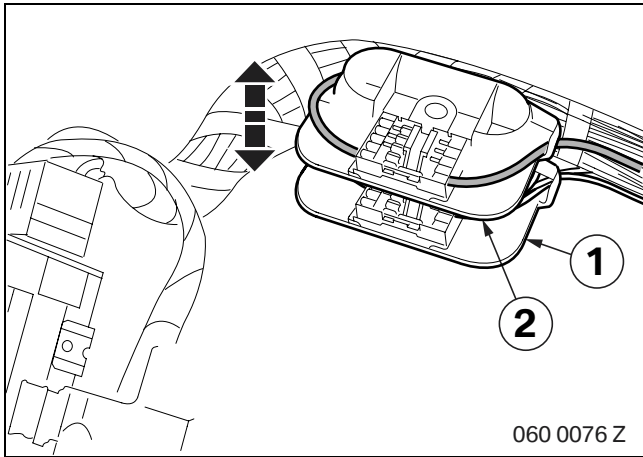

Disconnect the car distributor station (1) from the telephone distributor station (2).

 You can tell which is the telephone distributor station (2) because it has 2 fibre optic cables connected. The car distributor station (1) has several fibre optic cables. ◀

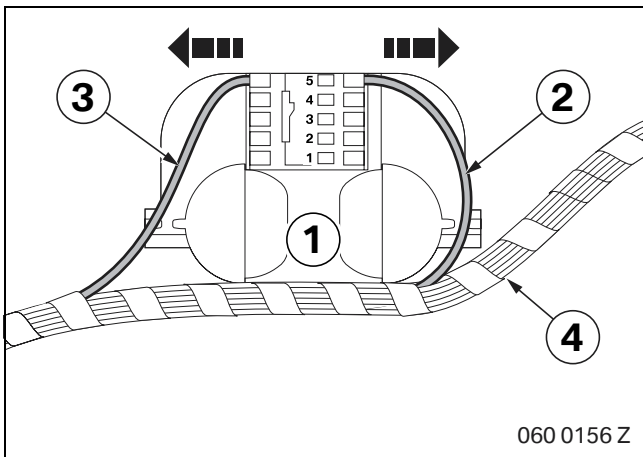

Disconnect the fibre optic cables (2 and 3) from the telephone distributor station (1).

Remove the telephone distributor station (1) from the wiring harness (4) (no longer required).

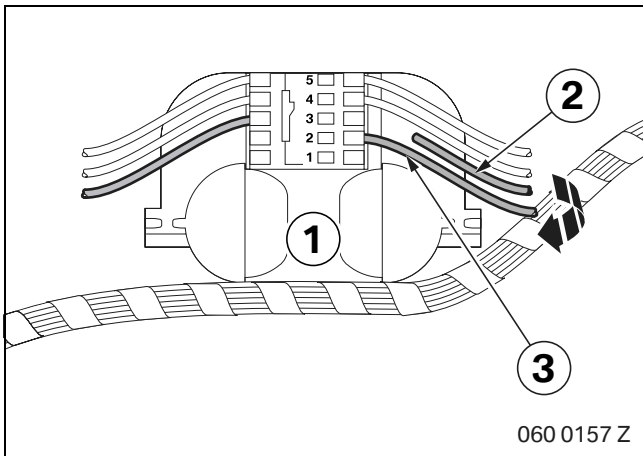

Disconnect the lowest fibre optic cable (2) from the car distributor station (1) and connect it to the unoccupied slot (3) below that.

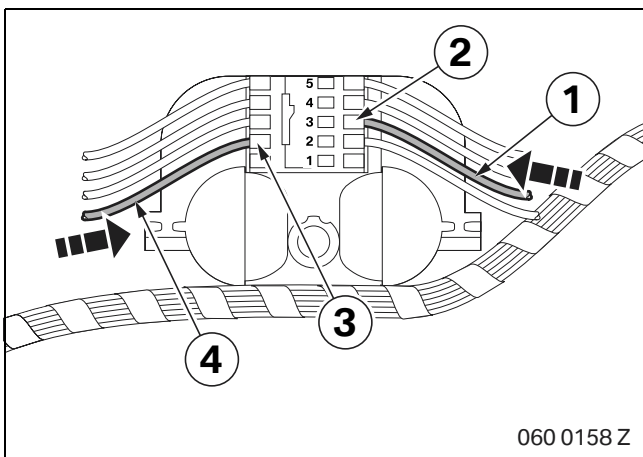

Connect the disconnected fibre optic cable (1) from the telephone distributor station to the now vacant slot (2).

Connect the fibre optic cable (4) from the telephone distributor station to slot (3).

5. To install and connect the telematics control unit

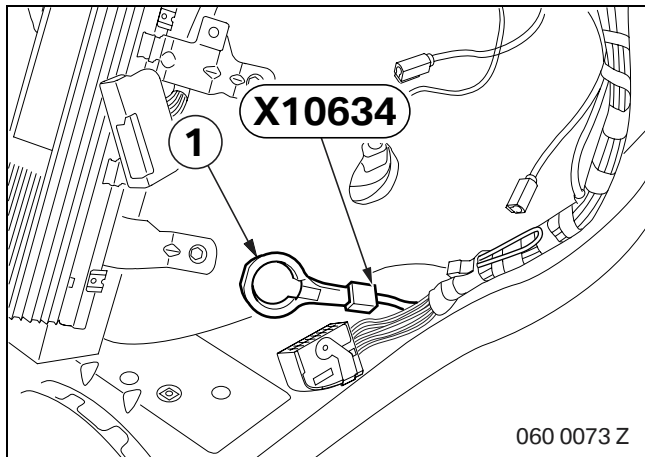

Disconnect the MOST diagnostic interface (1) from plug **X10634**.

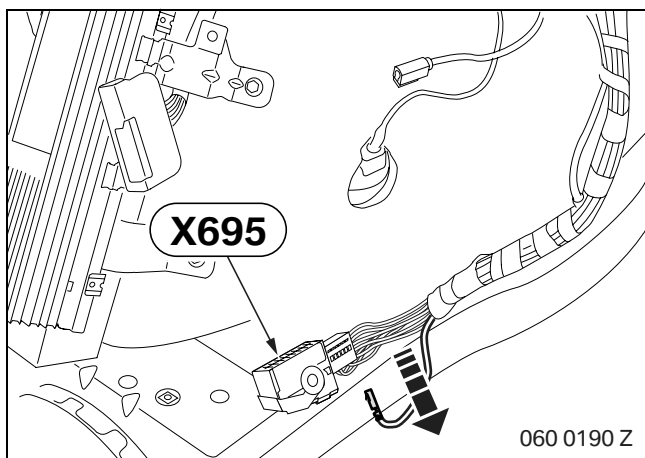

Cars up to 09/03 only

Unlock plug **X695**, disconnect the grey/brown cable from PIN 51 and tie it back.

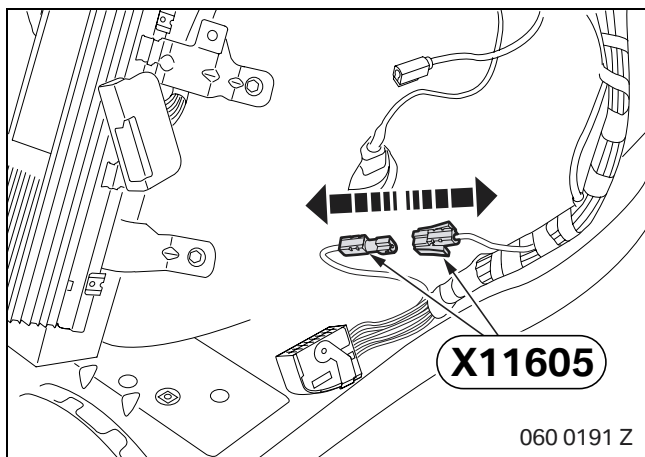

Cars from 09/03 only

Disconnect and tie back plug **X11605**.

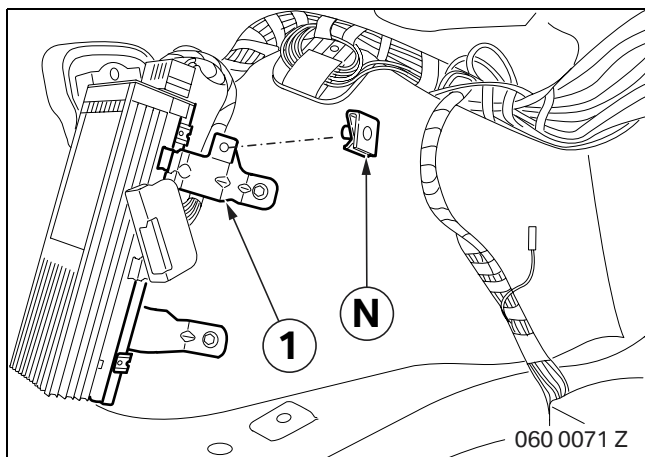

All cars

Place speed nut **N** on the holder (1).

5. To install and connect the telematics control unit

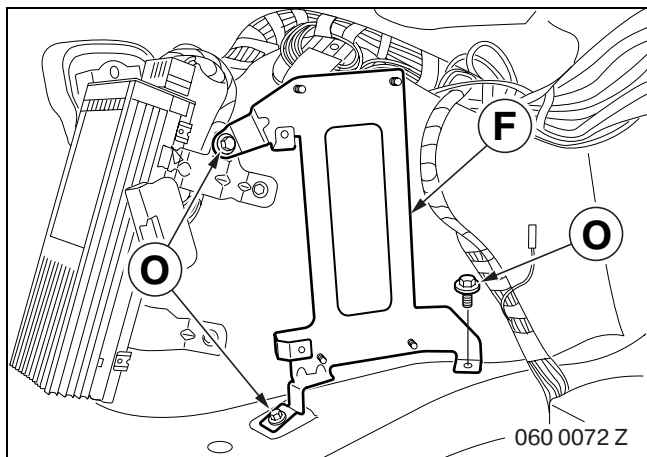

Screw on holder **F** using hexagonal screws **O**.

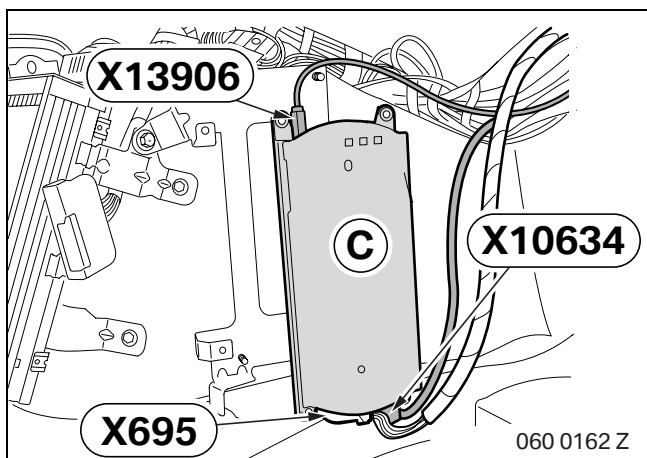

Connect aerial plug **X13906** to the same colour on telematics control unit **C**.

Connect white plug **X695** and black plug **X10634** to telematics control unit **C**.

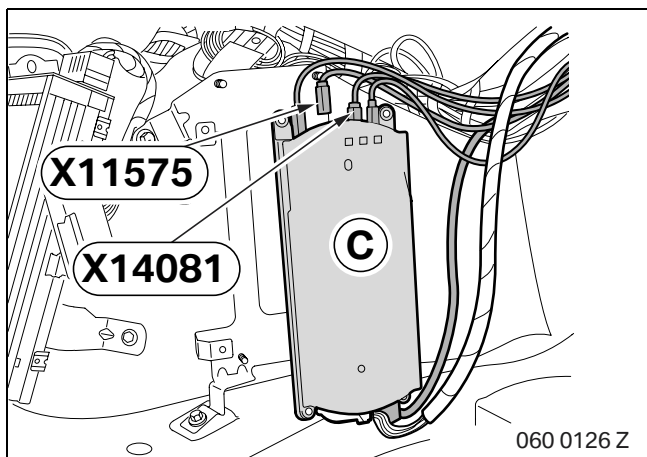

Cars up to 09/03 only

Connect plug **X14081** to telematics control unit **C**.

 Make sure that white plug **X14081** has continuity to plug **X14080** for the Bluetooth aerial under the rear window shelf. ◀

Plug **X11575** is not required, tie it back.

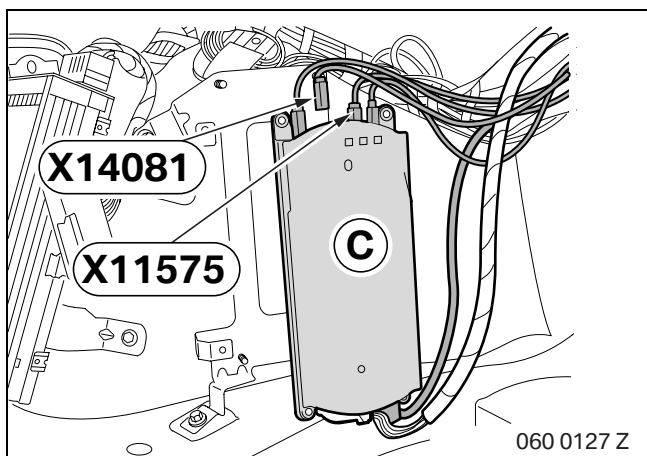

Cars from 09/03 only

Connect plug **X11575** to telematics control unit **C**.

 Make sure that white plug **X11575** has continuity to plug **X11574** for the Bluetooth aerial under the centre console. ◀

Plug **X14081** is not required, tie it back.

5. To install and connect the telematics control unit

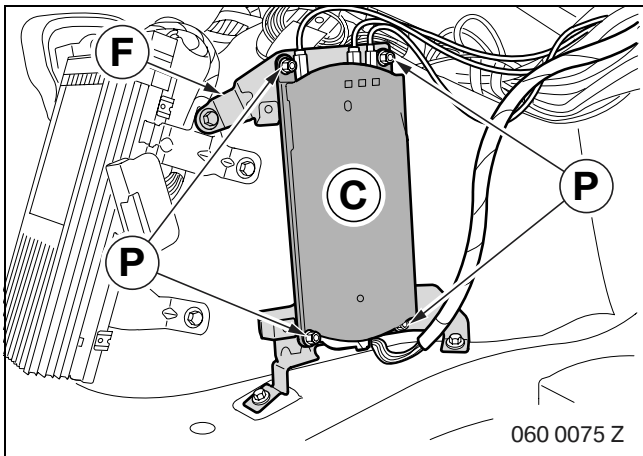

All cars

Use hexagonal nuts **P** to screw telematics control unit **C** onto holder **F**.

6. To install and connect the aerials

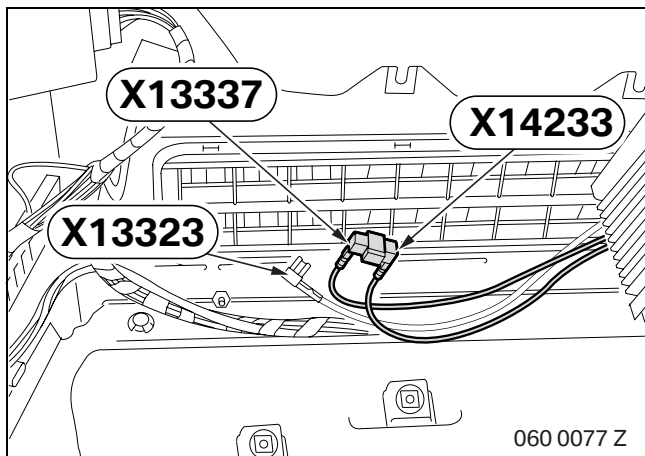

Connect plug **X13337** and plug **X14233** together.

Make sure that plug **X13337** from the roof aerial has continuity with plug **X14233** to the telematics control unit. ◀

Plug **X13323** is not required, tie it back.

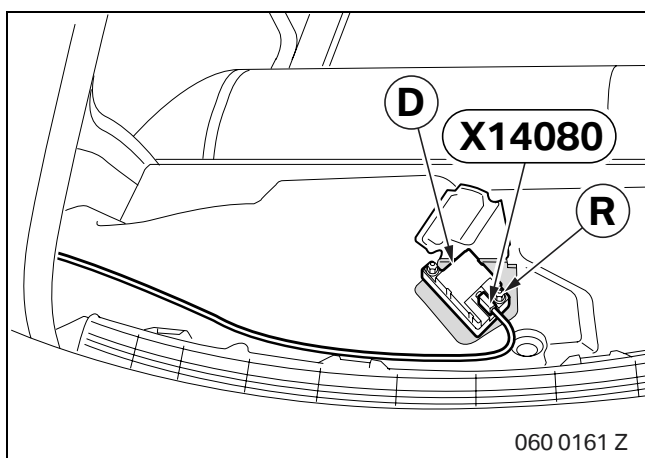

Cars up to 09/03 only

Cut out the noise insulation in the area where Bluetooth aerial **D** will be installed.

Use cap nut **R** to screw on Bluetooth aerial **D** and connect plug **X14080**.

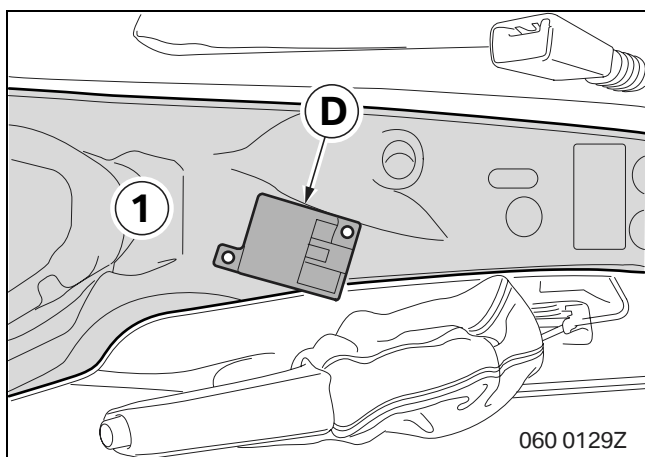

Cars from 09/03 only

Place Bluetooth aerial **D** onto the air duct (1), transfer the hole pattern and drill holes using a 2.5 mm drill bit.

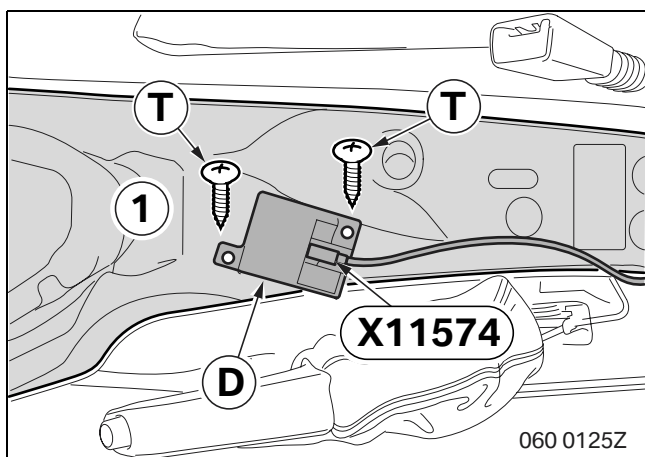

Use self-tapping screws **T** to screw Bluetooth aerial **D** onto the air duct (1).

Connect plug **X11574**.

7. To install and connect the eject box

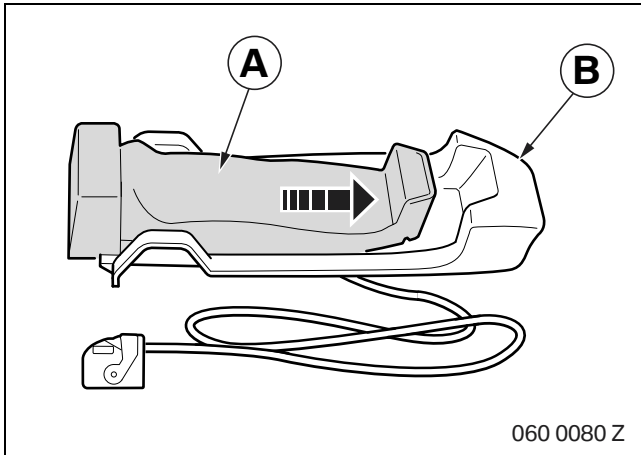

Plug eject box **A** into telephone mounting **B**.

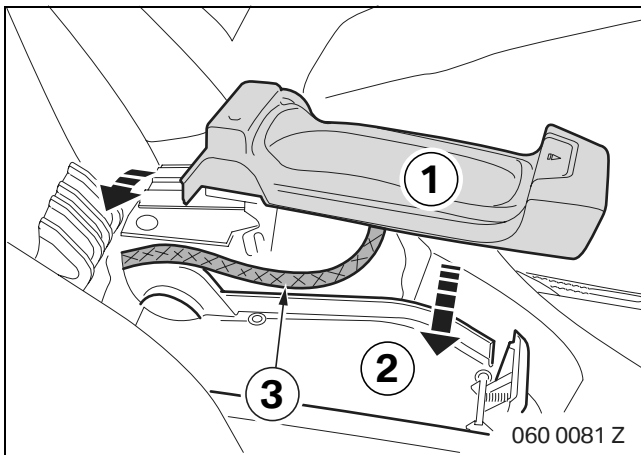

Route the cable (3) to the rear through the centre console oddments tray.

Insert the eject box (1) into the mounting (2).

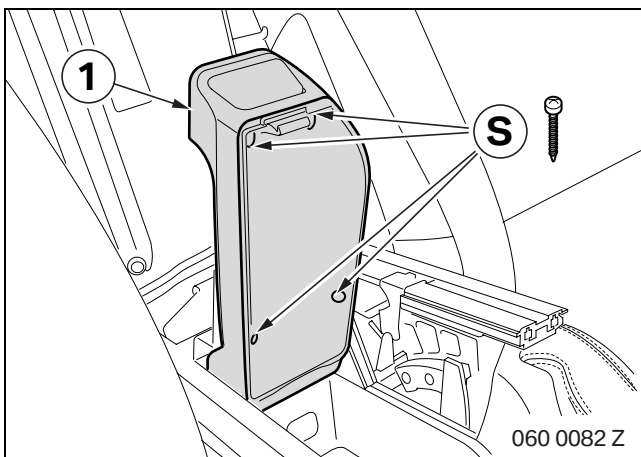

Use fillister head screws **S** to screw on the eject box.

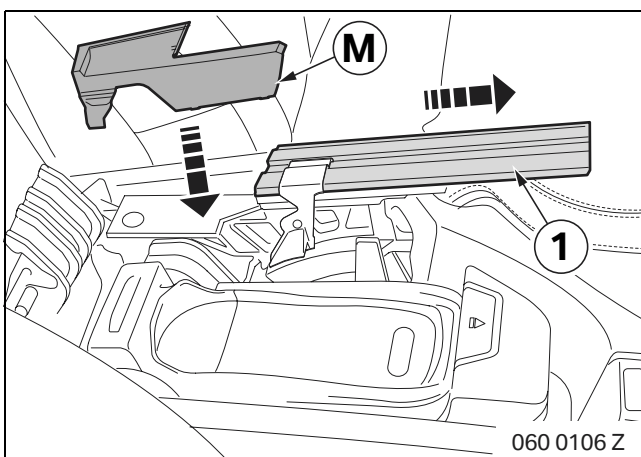

Clip centre armrest cover **M** into the centre console.

 Push the centre armrest adjustment unit (1) as far as possible towards the front of the car. This is only possible when the handbrake is released. ◀

7. To install and connect the eject box

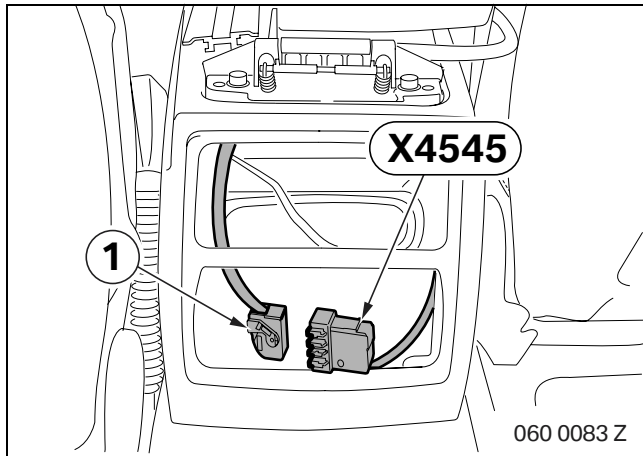

Connect plug **X4545** to the plug (1) of the eject box.

8. To install and connect the emergency call button and microphones

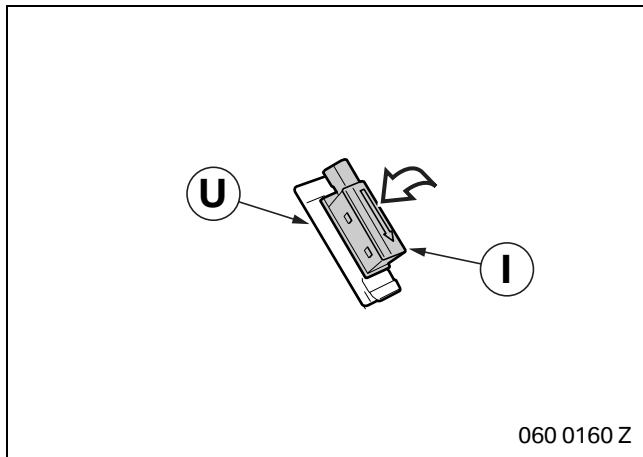

Clip microphone **I** into microphone trim **U**.

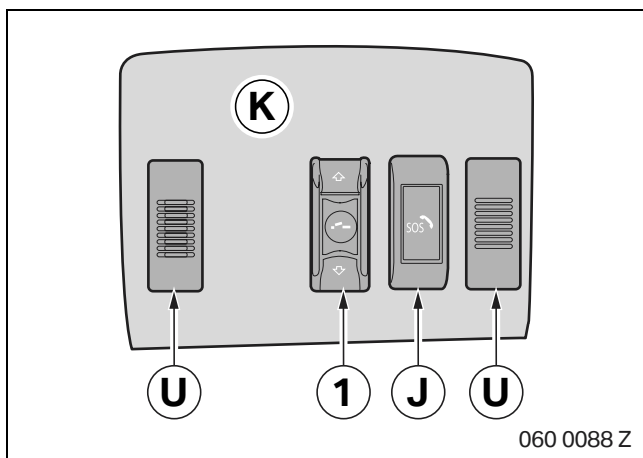

Cars with SA 403 only

Unclip the sliding/tilting roof button from the old trim.

 The arrow on microphone **U** must point to the front of the car. ◀

Clip microphone trim **U**, the sliding/tilting roof button (1) and emergency call button **J** into headlining trim **K**.

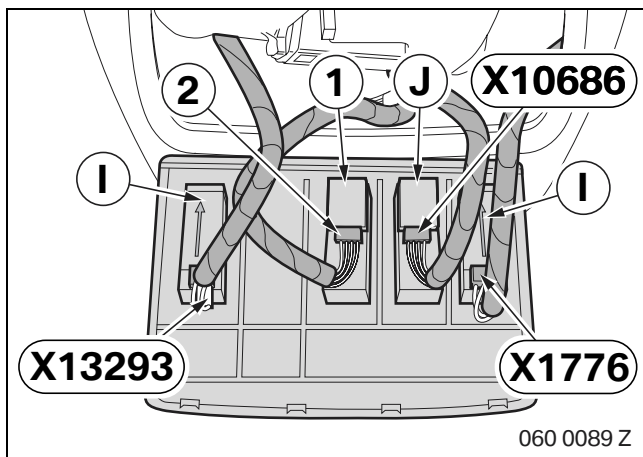

Connect the plug (2) to the sliding/tilting roof button (1).

Connect tied-back plugs **X1776** and **X13293** to microphones **I**.

Connect tied-back plug **X10686** to emergency call button **J**.

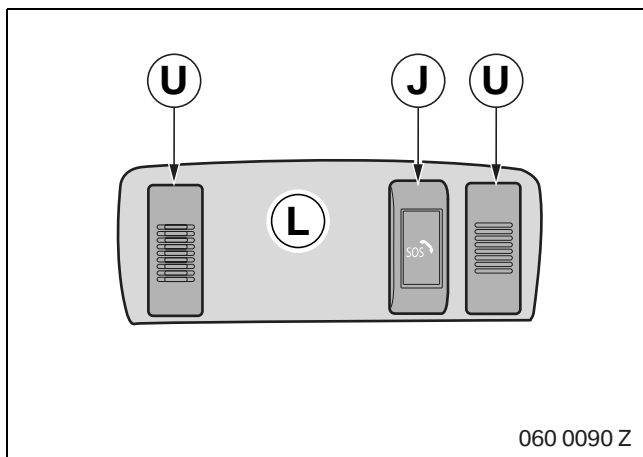

Cars without SA 403 only

 The arrow on microphone **U** must point to the front of the car. ◀

Clip microphone trim **U** and emergency call button **J** into headlining trim **L**.

8. To install and connect the emergency call button and microphones

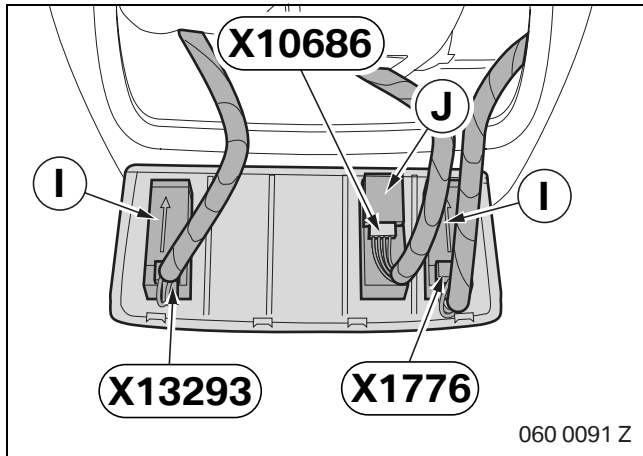

Connect tied-back plugs **X1776** and **X13293** to microphones **I**.

Connect tied-back plug **X10686** to emergency call button **J**.

9. Concluding work and coding



This upgrade system requires coding.

Until the coding CD CIP 9.0 becomes available (approx. 09/03), perform the coding manually by amending the car order. ◀

- Connect the battery
- Code the retrofit using DISPlus or GT-1 via path **Retrofit**
- Conduct a brief test
- Conduct a function test
- Re-assemble the car



Refer to DISPlus or GT-1 for the circuit diagram of the telephone preparation (SA 640), if required. ◀