Table of Contents

E6x 9/05 Model Updates

Subject	Page
Introduction	5
System Overview	7
Gateway	7
Servotronic	8
ECO Valve	8
Modifications to the System Network	8
Functions	11
Power Supply	11
Rear Power Distribution Box with RADSOK Contact	12
High Current Fuses	12
Relays in the Power Distribution Box	13
Energy Management	14
Energy Data Memory	15
Sleep Mode Preventers	15
Bus Wake-Up	16
Recording Data Records	16
Identification of Bus Wake-Ups	18
Micro-Power Module Integrated in KGM	18
Switch-On Conditions	19
Switch-Off Conditions	19
New MPM Functionality	20
Switch-Off of Terminal 30g_f Relay	20
Time Controlled Terminal Shutdown	21
Control Units Connected to Terminal 30	22
Car Access System 2	23
Comfort Access	26
Control Unit	26
Outer Door Handle	26
Capacitive Sensor 1	28
Capacitive Sensor 2	28
Antenna	29
Electric Steering Column Lock (ELV)	30

Subject	Page
Unlocking Steering Column with Comfort Access	31
Examples of Unlocking the Steering:	31
Locking Steering Column with Comfort Access	31
Examples of Locking the Steering:	31
Replacement of the Steering Column	31
START/STOP Button	32
Slot	32
Car Access System 2 (CAS 2)	32
Central Locking	36
Body Gateway Module (KGM)	36
Relays for Central Locking	37
Body Basic Module (KBM)	37
Interior Lighting	40
Doors	40
Door Exit Light	40
Courtesy Light	40
Sill Lighting E63	40
Driver's Door Switch Cluster	40
Backlighting (terminal 58g)	40
Power Windows	41
Front Windows	41
Body Gateway Module (KGM)	41
Body Basic Module (KBM)	41
Convertible Top Module (CVM) E64	41
Lowering the Side Window E63	42
Outside Mirrors	43
Mirror Control	43
Mirror Heating	44
Mirror Folding Function	44
Electrochromic Mirrors	44
Mirror Memory	44
Automatic Parking (curb viewer) Function	44
Safety Gateway Module	45
Functional Integration	45
Properties	48
Location	48

Subject	Page
Steering Column Switch Cluster	49
Component Overview	52
Electronic Steering Column Switch Cluster Module	53
F-CAN Link	53
PT-CAN Link	53
SZL Power Supply	53
Steering Angle Sensor	54
Steering Column Switches	54
Coil Spring Assembly	54
Locking	54
Functions	55
Detecting Steering Angle	55
Relative Steering Angle	56
Absolute Steering Angle	57
Steering Wheel Rotation Information	57
Detecting the Controls of the MFL	57

Model Updates

Model: E60/61/63/64

Production: from 9/2005

OBJECTIVES

After completion of this module you will be able to:

- Familiarize yourself with the changes in production as of 9/2005 production

Introduction

Several modifications will be implemented in the system network on the BMW5 Series and BMW 6 Series as part of the model year change in September 2005. The following models are affected by the modifications:

- E60, 5 Series Saloon
- E61, 5 Series Touring
- E63, 6 Series Coupé
- E64, 6 Series Convertible

Overview of model year measures implemented on the BMW5 Series and BMW 6 Series models

System	Remark
System Network Modifications	No byteflight New body-gateway module KGM Door module functions transferred to the KGM
Energy management	No micro-power module, function integrated in the KGM
Comfort Access	New key-less access system
Car Access System 2	Start/Stop button, slot, electric steering column lock
Expanded Diagnostic Functions	Monitoring of control units that wake the bus unauthorized Sleep mode preventer, control units that prevent the bus assuming sleep mode
Steering Column Switch Cluster	New connection to PT-CAN
Passive Safety	Changeover to advanced crash and safety management
Audio Systems	MP3 function in CCC

All control units belonging to the safety system have been replaced due to the fact that the Advanced Safety Electronics (ASE) and the optical bus system bytflight are no longer installed. The previous functions have been adopted by new control units.

A central control unit, i.e. the Advanced Crash and Safety Management (ACSM) module has been integrated in the K-CAN for functions of the passive safety system.

The safety and gateway module SGM has been replaced by the body-gateway module KGM. The body-gateway module incorporates not only parts of the SGM but also the door modules and the micro-power module MPM.

The installation location in the units carrier behind the glove compartment is the same.

Functions that have been adopted from the SGM in the KGM and have no changes are briefly described in the following.

New or expanded functions are described in the "Functions" section.

System Overview

Gateway

The KGM contains the gateway function and provides the interface between following busses:

- D-bus, diagnostic bus
- PT-CAN, powertrain CAN
- K-CAN, body CAN
- LIN-bus, local interconnect network

The task of the gateway is to interconnect the various bus systems.

The bus systems differ in terms of their data transmission rate or data telegram structure.

The data telegrams are buffered in the gateway and forwarded corresponding to their priority.

In connection with the diagnostic bus, the KGM forms the interface to the BMW diagnostic units and for the purpose of diagnosing or programming all control units connected to the bus system.

The KGM additionally features a link to the LIN-bus for the purpose of reading information from the driver's door switch cluster.



Control Unit Location (E64 shown)

Index	Explanation
1	Comfort Access
2	Panoramic Sunroof (MDS)
3	Body Basic Module (KBM)
4	Body Gateway Module (KGM)
5	CD Changer

Servotronic

The Servotronic controls the steering forces as a function of the driving speed. More steering assistance is provided when the vehicle is stationary or when parking than when driving at high speed on the motorway.

The Servotronic control function as well as the output stage for activating the Servotronic valve is integrated in the KGM if the vehicle is not equipped with AFS.

If the vehicle is equipped with AFS, the functional control is performed by the AFS control unit.

ECO Valve

An ECO valve (electrically controlled orifice) is installed in the hydraulic pump on vehicles equipped with active steering. The KGM controls ECO valve operation in the hydraulic pump for the power steering. The ECO valve controls the volumetric flow of the hydraulic pump corresponding to the power steering requirement, thus reducing fuel consumption.

Modifications to the System Network

Fundamental changes to the system network will be introduced on the BMW 5 Series and BMW 6 Series as from model year 2006.

Changing the passive safety system ASE to the advanced crash and safety management (ACSM) and the fact that the optical bus system byteflight is no longer installed result in several changes to the bus overview.

Following control units have been replaced:

- Safety and gateway module (SGM)
- B-pillar satellite, left
- B-pillar satellite, right
- Driver's door module (TMFA)
- Passenger's door module TMBF)
- Vehicle Center Satellite (SFZ)
- Micro-Power Module MPM)

The previous control unit functions have been integrated in new control units.

The steering column switch cluster that was previously connected to the system network via the byteflight is now connected to the PT-CAN.

The steering column switch cluster features extensive modifications and is therefore a new component.

New systems and control units will also be introduced with the model year measures.

New control units:

- Body-gateway module
- Advanced crash and safety management
- Comfort access
- High beam assistant
- IBOC (terrestrial digital radio - 10/2005 E63/4 only)

The newly added or modified control units are highlighted in the following bus overview.

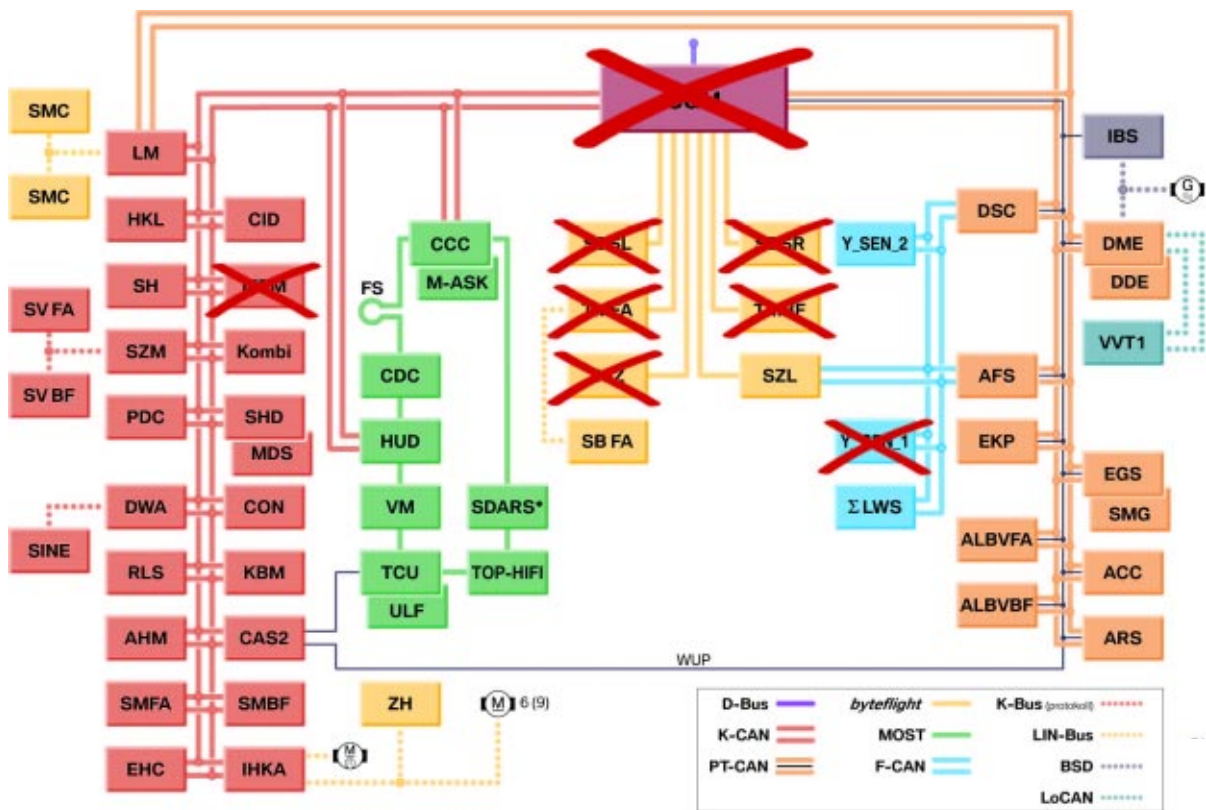

Bus Overview E60 up to 08/2005

Newly added or modified control units are circled in the following bus overview:

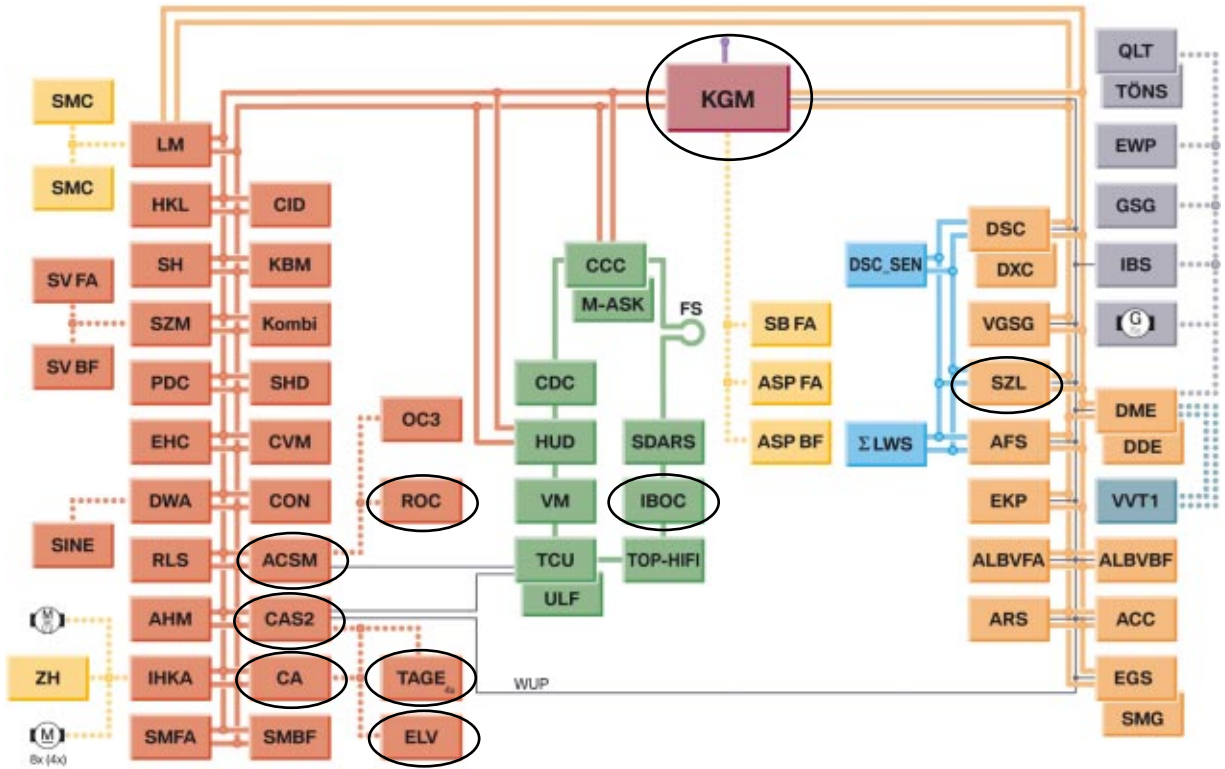

Bus Overview of New Control Units

Index	Explanation
KGM	Body Gateway Module
ACSM	Advanced Crash and Safety Management
CA	Comfort Access
CAS2	Car Access System 2
CCC	Car Communication Computer
ROC	Rollover Protection Controller
SZL	Steering Column Switch Cluster
ELV	Electric Steering Lock
TAGE	Electronic Outer Door Handle Module
IBOC	In-Band On-Channel (digital radio)

Functions

Power Supply

There are a few modifications to the power supply system, i.e. battery, alternator, starter, power distribution box, ignition lock.

The previous ignition lock with key-operated switch has been dropped and replaced by a Start-Stop button with terminal control. The Start-Stop button is described in detail in the section "Comfort access".

There are no changes to the battery, alternator and the starter.

The following changes have been made to the rear power distribution box:

- The mounting for the battery cable supplying power to the front power distribution box has been changed to a RADSOK contact.
- The high-current fuses are locked in the housing and cannot be replaced separately.

No changes have been made to the power distribution box at the front.

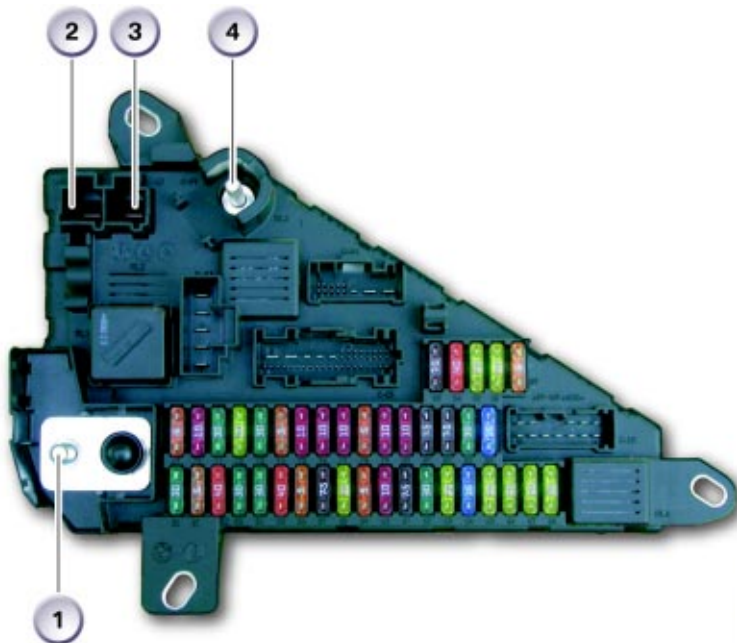

New Rear Power Distribution Box with Integrated Main Current Fuses and Relays.

Index	Explanation
1	Connection for Battery Cable
2	Not for US
3	Connection for common rail/Valvetronic
4	Connection for Front Power Distribution box (RADSOK)

Rear Power Distribution Box with RADSOK Contact

The rear power distribution box is equipped with a RADSOK contact for connecting the battery cable leading to the front power distribution box. RADSOK contacts are known and have already been used on the E65 power module.

The advantages of RADSOK contacts are in their design. The contact surface of the connector is equipped with spring elements.

The connection itself is not rigid but rather flexible. The high currents and resulting increase in temperature caused by the spring elements and the movement of the connector produce a self-cleaning effect of the contact surface. This ensures very good and uniform power transmission in connection with low contact resistance.

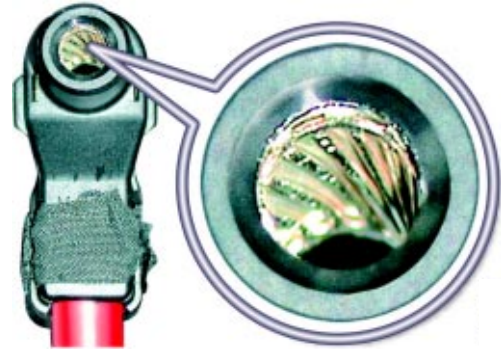

RADSOK Connector with Spring Elements

High Current Fuses

The high-current fuses are located on the underside of the power distribution box. The high-current fuses are for the:

- Front power distribution box
- Common rail or Valvetronic
- PTC auxiliary heater

The high-current fuses are connected directly to the battery. On the connector side, the high-current fuses are crimped to the power distribution box and cannot be replaced individually. The complete power distribution box must be replaced in the event of a defective fuse.

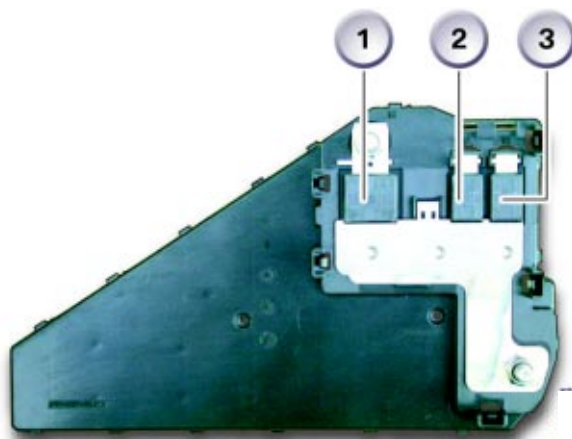

Index	Explanation
1	200 A for front power distribution box
2	100 A for common rail or Valvetronic
3	Not for US

Rear of Power Distribution Box with High Current Fuses

Relays in the Power Distribution Box

Three soldered relays are mounted on the pc-board of the rear power distribution box.

The terminal 30g relay is plugged in.

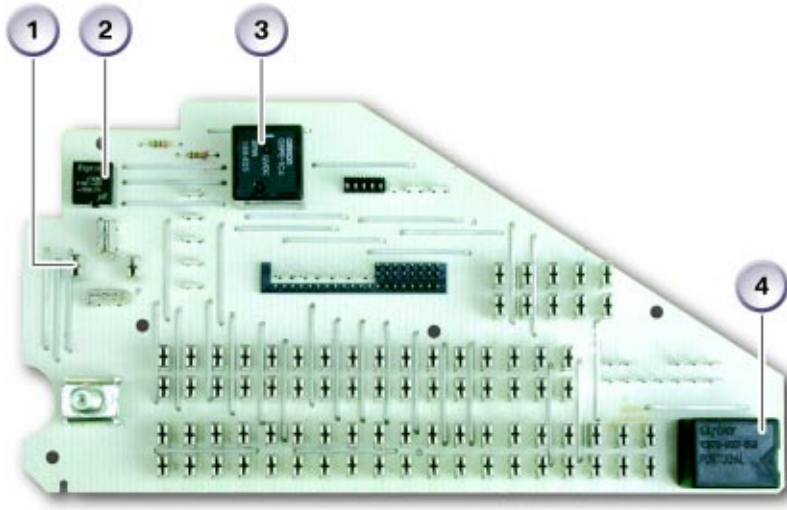

PC-Board of Rear Power Distribution Box

Index	Explanation
1	Plug-in contacts for terminal 30g relay
2	Relay for headlight washer system
3	Relay for rear window heater
4	Relay for terminal 15

Energy Management

Comprehensive measures have been introduced with the aim of further increasing customer satisfaction and to solve the problem of flat batteries. A flat battery is an annoying event for the customer.

There are various causes. Possible examples include:

- Unfavorable driving profile
 - Predominantly short-distance driving with insufficient battery charging (especially in winter)
- Increased closed-circuit current (> 80 mA)
 - Control unit is awake internally, the battery discharges after the vehicle has been parked several days.
- Sleep mode preventer (approximately 10 A)
 - A control unit does not sign off and the entire bus system remain awake. The battery is discharged after a few hours.
- Bus wake-up event
 - The bus system assumes sleep mode but is repeatedly woken by a control unit. The battery is generally discharged within one day.

Extensive measures have been implemented in the area of the energy management in order to counteract these problems. The measures concern following changes:

- Time-controlled terminal shut-down (terminal 30g)
 - All control units that need not necessarily be connected to terminal 30 are disconnected from the battery after a maximum of 60 minutes.
- Terminal shut-down in response to fault (terminal 30g_f)
 - Electric loads must switch off on request. If they do not switch off they will be disconnected from the battery.
- Sleep mode preventers
 - Control units that have not signed off and the sleep indicator bit is not set.
- Bus wake-up
 - Control units that wake up the bus system unauthorized.

The micro-power module and the energy data memory have been integrated in the body gateway module to facilitate these measures.

Energy Data Memory

The energy data memory is the expansion of the previous history memory as was used in the SGM. An indicator as to what bus system woke the vehicle was stored in the history memory.

The expanded function of the energy data memory determines:

- Which control unit prevents the bus system from assuming sleep mode
- How often a control unit wakes the bus system and therefore the entire vehicle
- Which control unit has woken the bus system and therefore the entire vehicle

The energy data memory is subdivided into three areas containing following information:

- Sleep mode preventer
- Number of bus wake-ups
- ID of bus wake-ups

A further processor, the co-processor, is necessary for this purpose. Since the body gateway module (KGM) itself assumes sleep mode and the main processor is therefore switched off, it would not at all notice a short bus wakeup event. It is therefore necessary to permanently monitor the bus sleep phase with a further processor. The identifier is stored in response to a bus telegram.

Besides the ID of the CAN telegram, the km reading and the relative time are also stored. Conclusions with regard to the driving profile and the stationary periods can be drawn with the aid of these data. This facilitates more simple and accurate diagnosis of the control unit causing the problem.

Furthermore, the system is able to determine which control unit prevents the bus system assuming sleep mode.

Sleep Mode Preventers

After terminal R OFF, control units must sign off from their network master (KGM, CCC, MASK) and signal their readiness to assume sleep mode.

All control units that signal that they are ready to assume sleep mode by setting the sleep indicator bit 20 minutes after terminal R OFF are classified as sleep preventers.

The diagnostic address of the respective control unit is used for the purpose of identifying the cause.

The same procedure applies after a bus wakeup without terminal R ON.

Monitoring by the body-gateway module takes place at 5, 10, 15, 20 minutes after terminal R OFF. All control units found 3 times not to have assumed sleep mode are entered as sleep mode preventers in the data memory.

As part of its gateway function, the KGM is generally the last control unit to set the sleep indicator bit. It is entered as a sleep mode preventer only when it is the only control unit that has not yet signalled its readiness to assume sleep mode.

Bus Wake-Up

Control units that wake the bus system without authorization and cause a high closed circuit current are referred to as bus wake-ups.

The identity of each control unit that sends a bus telegram is stored in the telegram identifier. Therefore, every telegram can be assigned to a control unit. Data records are created for monitoring and recording purposes.

■ Recording Data Records

The recording procedure for the relative time from the instrument cluster is started when battery voltage is applied. The relative time is a consecutive counter that is started when the battery voltage is applied for the first time at the factory. A new data record is started with every battery reset.

A data record is recorded over 1 week (168 h). After the 168 hours have elapsed, the data record is stored and recording of the second data record begins.

All statuses between two terminal R switch-on operations are recorded. The recording takes into account whether the terminal 30g relay was ON or OFF. A maximum of 254 entries can be stored. The counter stops at 254 when the maximum number of 254 entries is exceeded. The same also applies to the number of recorded trips.

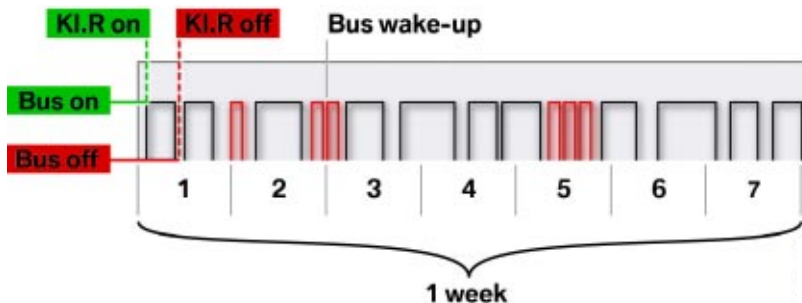

Schematic Representation of a Data Record

Index	Explanation
KI.R on	Terminal R is switched on/normal activity on the bus
KI.R off	Terminal R is switched off, the bus is at rest up to next terminal R on
Bus wake-up	Unauthorized bus wake-up during bus rest and terminal R OFF
Bus on	Normal bus activity
Bus off	Bus at rest, normally no activity on the bus
1.....7	Days of recording
1 week	Duration of a data record

A total of 6 data records are recorded in the ring memory, facilitating subsequent diagnosis over this period in order to obtain a more accurate overall picture of the driving profile.

The following information is stored in a data record:

- Start of recording (relative time)
- Total distance covered in km up to the next recording
- Number of trips of 0 - 5 km
- Number of trips of 5 - 20 km
- Number of trips of 20 - 100 km
- Number of trips of > 100 km
- Number of bus wake-ups

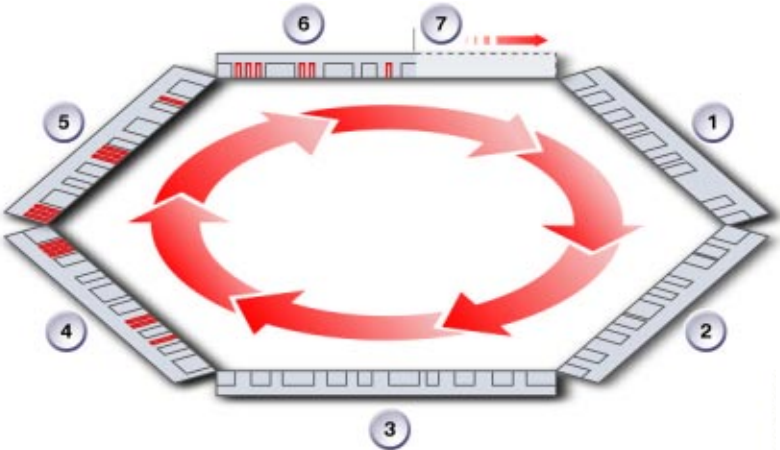

Principle Design of the Ring Memory

Index	Explanation
1	Data record of the first week without bus wake-up events
2	Data record of the second week without bus wake-up events
3	Data record of the third week without bus wake-up events
4	Data record of the fourth week with bus wake-up recording
5	Data record of the fifth week with bus wake-up recording
6	Data record of the current week with bus wake-up recording
7	Current recording status

■ Identification of Bus Wake-Ups

When entering the bus wake-up in the data record, the identifier of the bus telegram that has woken the bus as well as the relative time and the current km-reading are stored in a separate area of the energy data memory. This enables distinct identification of the control unit that has woken the bus.

Micro-Power Module Integrated in KGM

There is no micro-power module as a separate control unit. The entire function, including the bistable relay terminal 30g_f has been integrated in the body-gateway module. The relay terminal 30g_f is soldered on the pc board. The ON/OFF statuses of the relay are stored in the KGM.

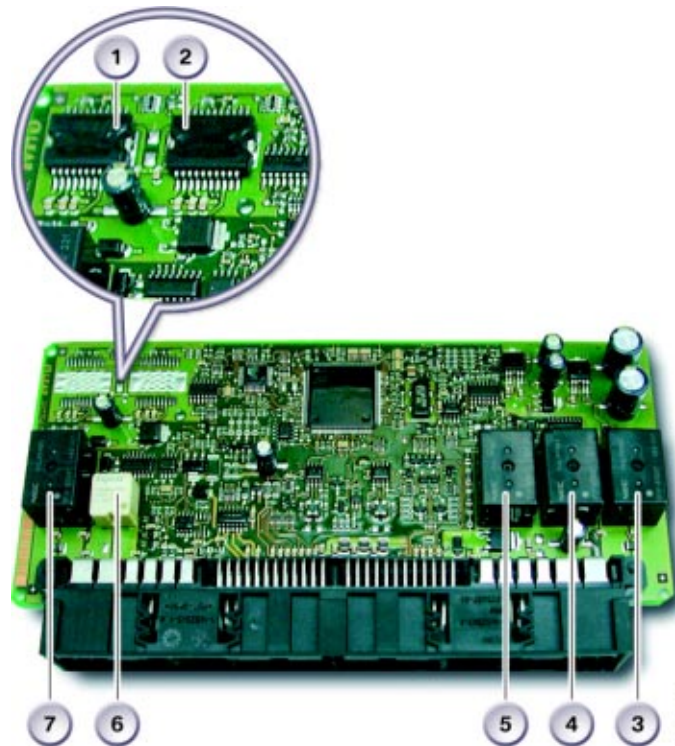

Inside of KGM with Relays

Index	Explanation
1	Output stage for outside mirror on left
2	Output stage for outside mirror on right
3	Relay for passenger's power window
4	Double relay for central locking, central arrest/lock
5	Double relay for central locking, unlock/lock
6	Terminal 30g_f relay
7	Relay for driver's power window

The following loads are connected to the terminal 30g_f relay:

- Instrument cluster
- Comfort access CA
- Car communication computer/multi-audio system controller CCC/MASK
- CD changer CDC
- Telematics control unit (TCU)

■ Switch-On Conditions

The relay is always activated and switched to ON when one of the following conditions applies:

- When the battery is connected for the first time
- Vehicle unlocked
- Change in status of door contacts or boot lid
- Terminal R ON

■ Switch-Off Conditions

The intelligent battery sensor IBS permanently monitors the closed-circuit current. The electric loads are requested to switch themselves off if the closed-circuit current is too high and the start capability limit of the battery is reached. An after running time of 2 minutes is coded for this purpose. A reset is implemented if the closed-circuit current is still too high after 2 minutes or one of the following conditions applies.

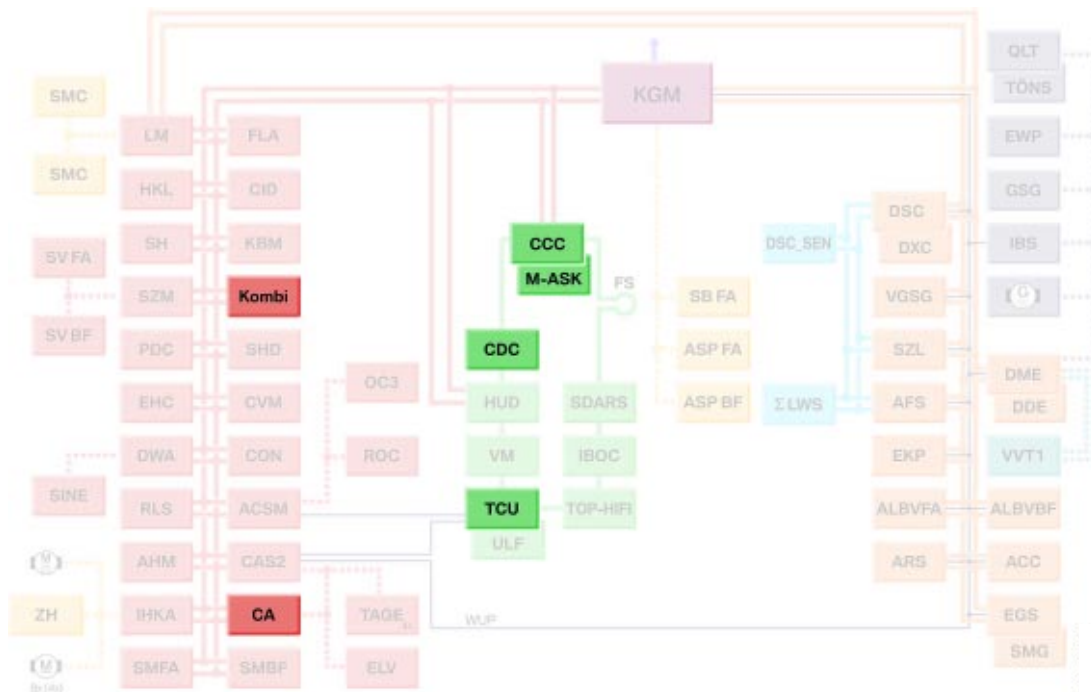

Overview of Control Units Connected to Terminal 30g_f Relay

■ **New MPM Functionality**

A 10 second relay is performed before the KGM finally switches off the terminal 30g_f relay. This is intended to eliminate any malfunctions in the control unit.

Reset conditions

- Closed-circuit current of electric loads too high
- Bus active for 60 minutes even though no switch-on condition applies
- Bus is woken 30 times even though no switch-on condition applies

The terminal 30g_f relay is switched off for 10 seconds and then switched on again as part of the reset procedure. The system is monitored again after the reset.

■ **Switch-Off of Terminal 30g_f Relay**

Terminal 30g_f relay is opened (OFF) if one of the following conditions applies during the monitoring phase.

- Start capability limit reached
- 5 bus wake-up events with no switch-on condition
- 10 min. bus activity

The switch-off or reset is stored in the info memory of the KGM. The following information is also stored:

- Current kilometer reading
- Relative time
- Status of relay (ON/OFF)
- Counter that indicates how often the relay is switched on

■ Time Controlled Terminal Shutdown

In order to improve the energy balance, the Car Access control unit 2 (CAS 2) switches off via the terminal 30g relay all control units that need not necessarily be connected to terminal 30 after 30 minutes or after 60 minutes if a telephone is installed.

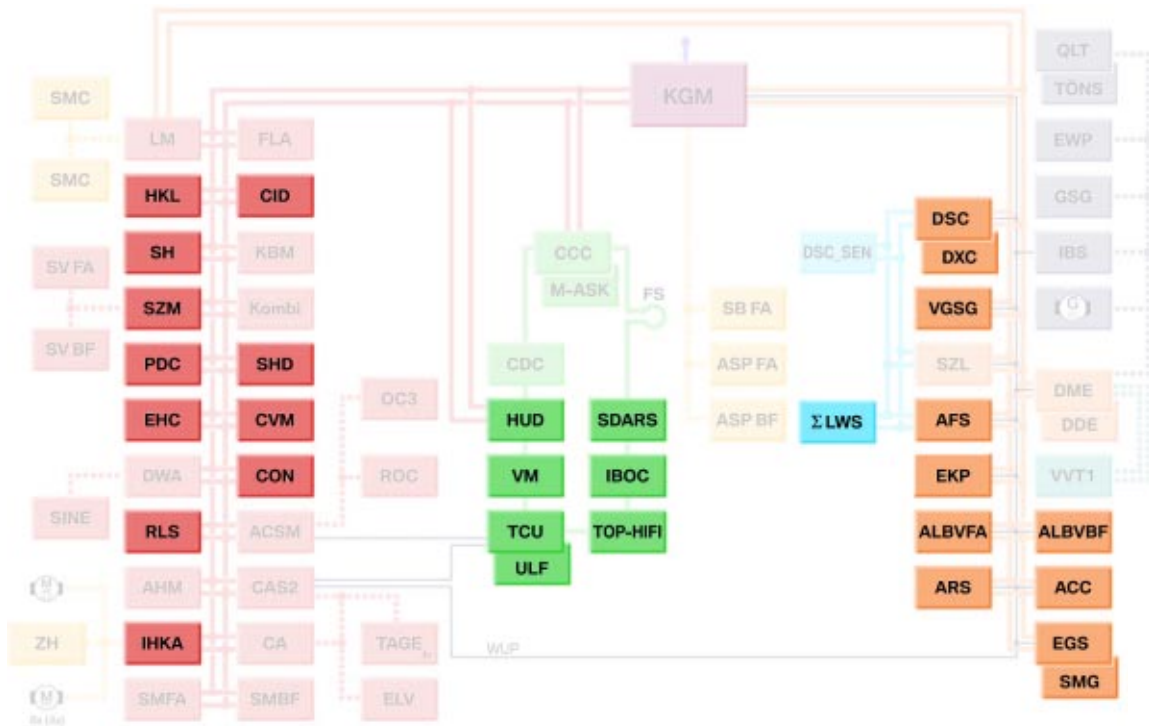

Overview of Control Units Connected to Terminal 30g

■ Control Units Connected to Terminal 30

A few control units cannot be switched off due to their functionality.

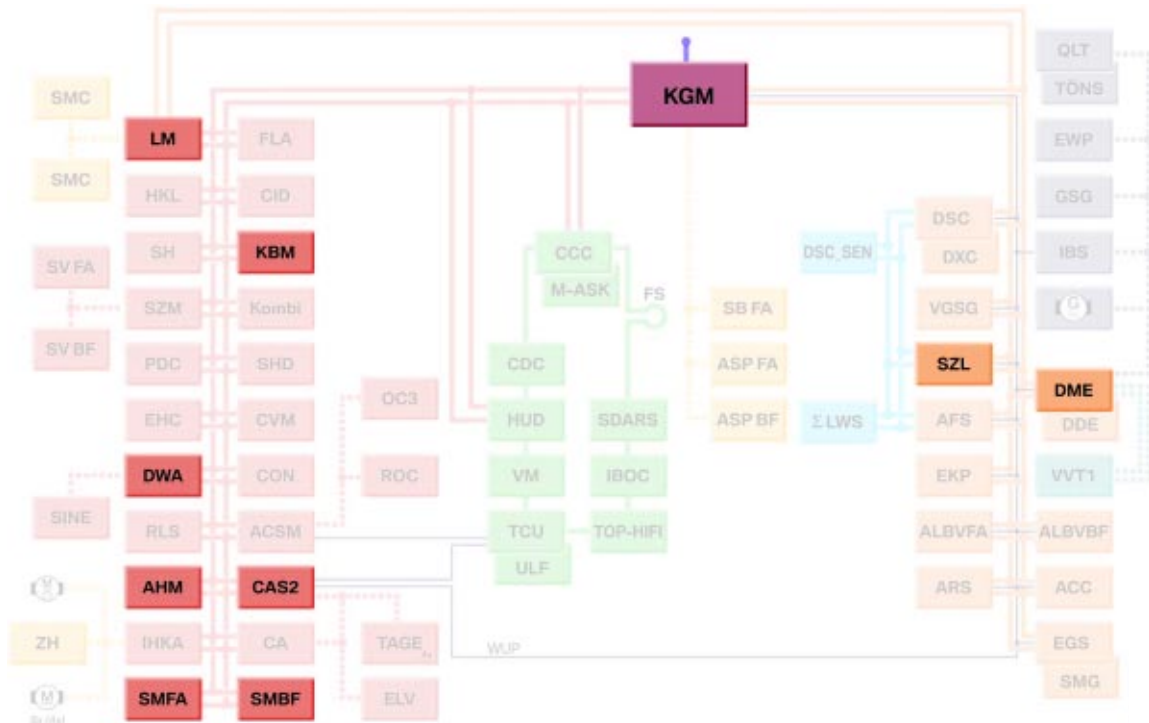

Overview of Control Units Connected to Terminal 30 (continuous positive)

Reasons for staying connected to terminal 30:

Control Unit	Reason
KGM	Due to the master functionality
LM	Due to the legally required hazard warning function
KBM	Due to the Hall sensors for window monitoring
DWA	Due to the interior monitoring function
AHM	Due to the legally required hazard warning function
CAS	Due to the vehicle unlocking function
SMFA	Due to the high current consumption of the seat heating
SMBF	Due to the high current consumption of the seat heating
SZL	Due to the steering angle sensor whose data are held only in a volatile memory
DME	Due to the power management

Car Access System 2

The previous turn-key concept will be replaced as from September 05 (steering column lock and start engine). Instead, the BMW 5 Series and BMW 6 Series will be equipped with an electric steering column lock as well as the operating concept with the Start-Stop button from the E90.

The car access system 2 is adopted from the E90. This means various functions and components from the E90 are now also available on the BMW 5 Series and BMW 6 Series.

The functions and components are:

- Slot for remote control or identification transmitter
- Electric steering column lock ELV
- START/STOP button
- Comfort access



The car access system still features master functions such as:

- Remote control services
- Power windows
- Electric steering column lock (ELV)
- Sunroof/panoramic glass roof
- Vehicle data storage
- Central locking
- Comfort Access
- Power windows
- Electric vehicle immobilizer
- Terminal control



Start-Stop Button and Slot

Index	Explanation
1	START/STOP Button
2	2 Slot

CAS 2 System Circuit Diagram

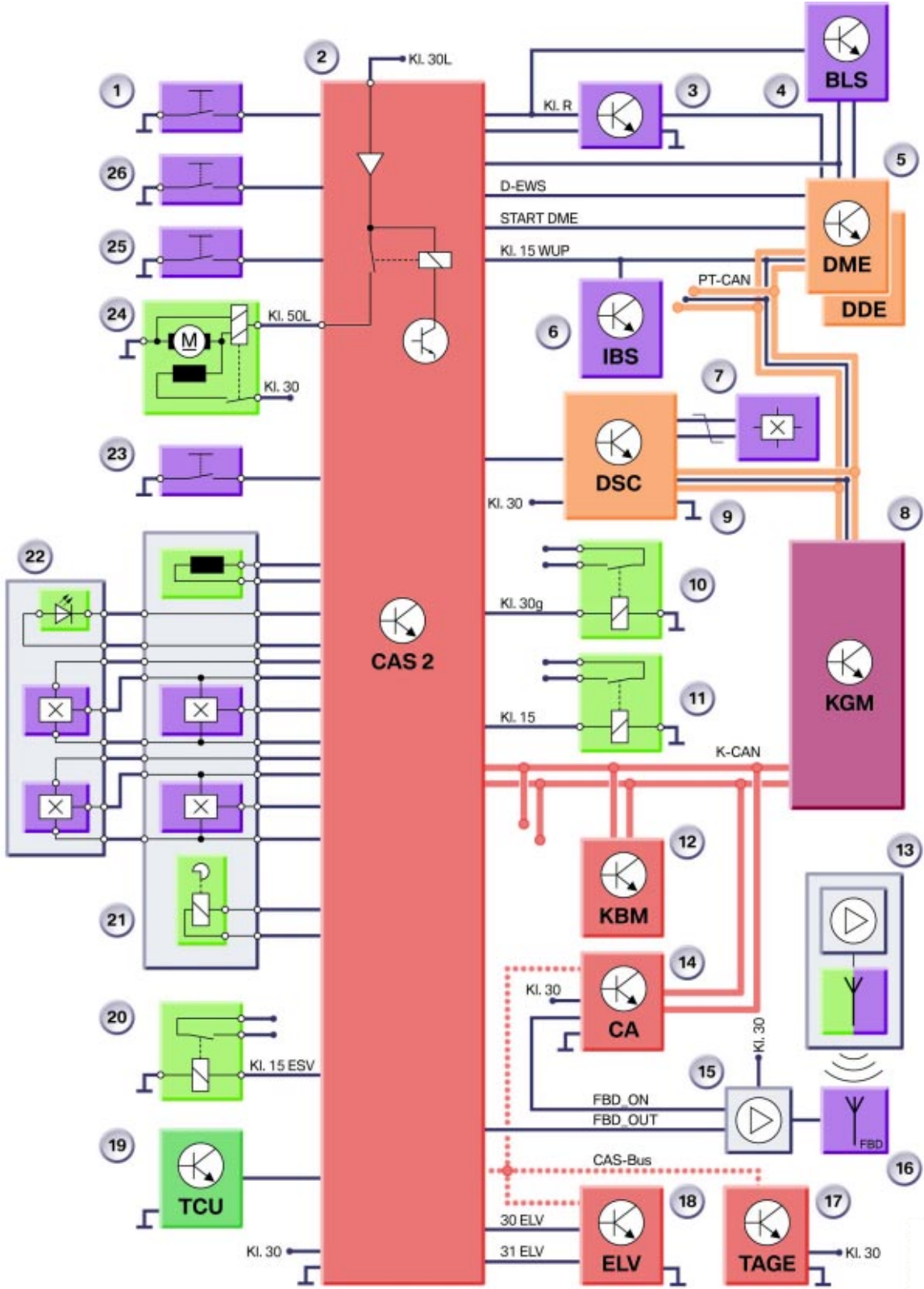

Legend for CAS 2 System Circuit Diagram

Index	Explanation	Index	Explanation
1	Bonnet contact switch	23	Boot lid button, interior
2	Car access system 2 (CAS 2)	24	Starter
3	Brake light switch (BLS)	25	Center-lock button
4	Clutch switch	26	Hotel switch
5	Digital motor electronics (DME)	KI. R	Terminal R
6	Intelligent battery sensor (IBS)	KI. 15	Terminal 15
7	Wheel speed sensor	KL 15 WUP	Terminal 15 wake-up
8	Body-gateway module (KGM)	KL 15 ESV	Terminal 15, fuel injectors
9	Dynamic stability control (DSC)	KL 30	Terminal 30
10	Terminal 30g relay	KL 30g	Terminal 30 switched
11	Terminal 15, unloader relay	KL 30L	Terminal 30, load
12	Basic body module (KBM)	KL 50L	Terminal 50, load
13	Identification transmitter	CAS-Bus	CAS-bus
14	Comfort access (CA)	K-CAN	Body CAN
15	Remote control receiver	PT-CAN	Powertrain CAN
16	Remote control services - antenna signal	EWS	Electronic vehicle immobilizer
17	Electronic outer door handle module (TAGE)	START-DME	Start, digital motor electronics (DME)
18	Electric steering lock (ELV)	30 ELV	Positive supply ELV
19	Telematics control unit (TCU)	31 ELV	Ground supply ELV
20	Relay, fuel injectors	FBD	Remote control services
21	Slot	FBD ON	Remote control services ON
22	START/STOP button	FBD OUT	Remote control services OUT

On the E60, E61 and E63, the antenna for the remote control services is installed integrated in the rear window. The antenna for the remote control services on the E64 is located in the interior rear-view mirror.

The terminal 30g relay is located in the power distribution box in the luggage compartment.

The terminal 30g_f relay is installed in the body-gateway module (KGM).

Comfort Access

As from 09/2005 the E60, E61, E63 and E64 can be equipped with the comfort access system (can be ordered as an option). These models therefore also feature "keyless" access.

These models will also be equipped with following components:

- START/STOP button
- Slot for identification transmitter
- Electric steering column lock
- Car access system 2 (adopted from E90)

Note: Comfort access is based on the comfort access system from the E90 and E91. On vehicles equipped with comfort access, the CAS 2 has the master function for comfort access.

Control Unit

The comfort access control unit is installed in the units carrier behind the glove compartment. The electronic module for the comfort access system is accommodated in a hard-shell housing. The connector socket has 26 pins. The fuses for the comfort access system are located in the power distribution box behind the glove compartment.

With the exception of the antennas for the outer door handles which are activated directly by the respective electronic outer door handle module, all antennas are connected directly to the comfort access control unit.

The comfort access control unit, electronic outer door handle modules and the car access system 2 are interconnected by the CAS-bus.

The CAS-bus is a bus system based on the K-bus. Faults in the electronic outer door handle modules are stored in the fault code memory of the comfort access system.

Comfort access therefore also serves as the diagnostic interface for the electronic outer door handle modules.

Outer Door Handle

The previous exterior door handle is retained in full. For comfort access, an electronics box is mounted on the inside of the outer door handle. The complete outer door handle electronics, the inductive antenna and the capacitive sensor 1 are housed in the electronics box. The sensitive area on the outer door handles represents the capacitive sensor 2.

The sensitive area is located directly next to the lock barrel on the driver's door or on the fixed part on the outer door handles on the other doors. The Hall sensor for identifying when the outer door handle is pulled is located next to the electronics box.

The status of the Hall sensor changes when the outer door handle is pulled. This change in status is detected by the electronics of the outer door handle. The vehicle is unlocked by pulling the outer door handle twice within a short space of time.

The electronic outer door handle modules are connected via the CAS-bus to comfort access, car access 2 and the electric steering lock.

Depending on the type of vehicle, two to four electronic outer door handle modules can be installed for the comfort access system. See following table:

Electronic Outer Door Handle Module	E60	E61	E63	E64
Driver's door	✓	✓	✓	✓
Front Passenger's door	✓	✓	✓	✓
Rear Driver's side door	✓	✓		
Rear Passenger's side door	✓	✓		
Total	4	4	2	2

Note: A defective electronic outer door handle module or a short to ground can disturb communication via the CAS-bus. As a result, the fault code "ELV defective" can be entered in the fault code memory for the electric steering lock.

Capacitive Sensor 1

The functional principle of the capacitive sensor is already known from the E87/E90/E91.

The capacitor plate from the outer door handle, however, has been repositioned behind the handle plate. The capacitor plate is located in an electronics box that is mounted directly on the handle plate.

An electric field is generated in the area of the door handle plate of the outer door handles. The electric field is changed by grasping into the recessed plate of the outer door handle.

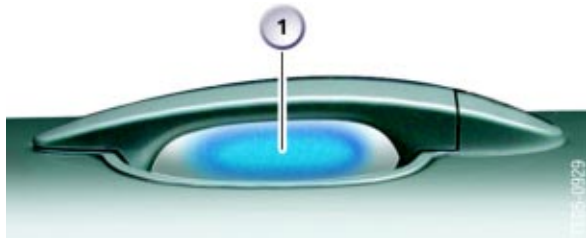

Index	Explanation
1	Electric Field

Electric Field of Capacitive Sensor 1

This in turn generates a pulse which is evaluated by the electronic module in the outer door handle for the purpose of transferring the unlock request to the comfort access system.

Capacitive Sensor 2

The capacitive sensor 2 is responsible for the vehicle locking operation. The lock is triggered by touching the sensitive area. The sensitive area is shown in the following graphic.

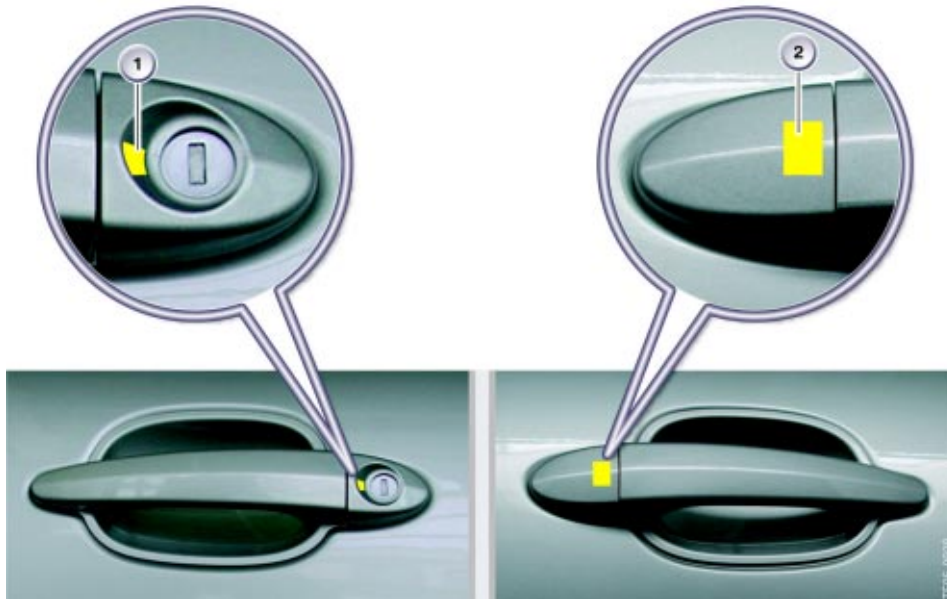

Sensitive Area of Capacitor 2

Index	Explanation	Index	Explanation
1	Rear View	2	Center of Rotation

Antenna

Three or five antennas for the exterior and four antennas for the vehicle interior are used per vehicle.

The antennas for the vehicle interior and in the bumper are of the same design as the antennas used on the E90.

The antennas in the luggage compartment of the E63 and E64 are integrated in the foam material padding.

Antenna		E60	E61	E63	E64
Interior	Centre Console, front	✓	✓	✓	✓
	Centre Console, rear	✓	✓		
	Rear Window Shelf	✓		✓	
	Luggage Compartment, centre	✓	✓		
	Luggage Compartment, left			✓	✓
	Luggage Compartment, right			✓	✓
	Luggage Compartment, load sill		✓		
Exterior	On Left of Rear Bumper	✓	✓	✓	✓
	Outer Door Handle	4	4	2	2

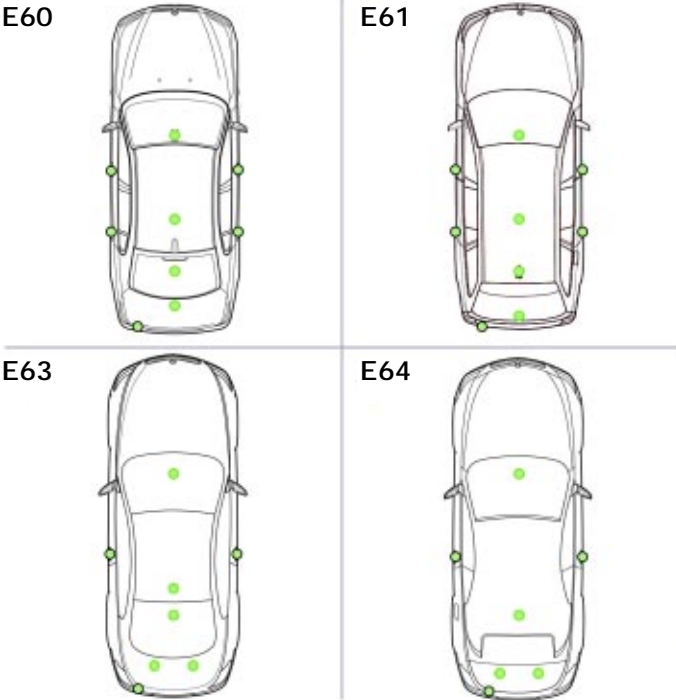

Antenna Locations by Vehicle

Electric Steering Column Lock (ELV)

The BMW 5 Series and BMW 6 Series can be equipped with the option SA 245 Electric steering column adjustment. This option effects the installation location of the electric steering column lock.

In connection with a mechanically adjustable steering column, the electric steering column lock is secured from below on the steering column.

If an electrically adjustable steering column is installed, the electric steering column lock is mounted with two screws on the side of the steering column.



Electrically Adjustable Steering Column

Index	Explanation
1	Car Access System 2 (CAS 2)
2	Electric Steering Column Lock
3	START/STOP Button
4	Slot

Unlocking Steering Column with Comfort Access

The steering is unlocked under various conditions. A fundamental condition required for unlocking the vehicle is the detection of a valid identification transmitter in the interior.

The steering unlocking operation is triggered with the status "terminal R ON".

■ Examples of Unlocking the Steering:

Unlock Steering

- *Driver's door unlocked and opened:*
The steering is unlocked when a valid identification transmitter is detected in the vehicle interior 3 seconds after opening the door.
- *Driver's door unlocked and opened:*
If more than 3 seconds has elapsed after opening the driver's door, the search for a valid identification transmitter in the vehicle interior is started when the last door of the vehicle is closed. The steering is unlocked if the search in the vehicle interior is successful.
- *Driver's door unlocked and opened:*
More than 3 seconds has elapsed after opening the driver's door and the driver's door remains open. Terminal R ON can be selected with the START/STOP button and the steering is unlocked.
- A locked steering can be unlocked by inserting the identification transmitter in its slot.

Locking Steering Column with Comfort Access

The steering can be locked only under certain conditions. A fundamental condition is that the vehicle is stationary and the engine is turned off. The steering locking operation is triggered with the status "terminal R OFF".

■ Examples of Locking the Steering:

Locking Steering

- Terminal 15 OFF with the START/STOP button followed by the central arrest command of the central locking system. The central arrest can be triggered with the remote control in the identification transmitter or via the "lock" capacitive sensor at the outer door handle.
- The steering can be locked by removing the identification transmitter from its slot.

Replacement of the Steering Column

If defective, the electric steering column lock can be replaced on the electrically adjustable steering column. The electric steering column lock is included in the scope of delivery of a new steering column.

START/STOP Button

The START/STOP button has been adopted from the E90 and adapted to the vehicle design. The START/STOP button features two Hall sensors. With the aid of the Hall sensors, the car access system 2 registers when the START/STOP button is pressed. Button operation can still be detected if one of the Hall sensors fails.

The lighting of the START/STOP button is powered by the car access system 2.

Slot

The slot for the identification transmitter has been adopted from the E90 but is now installed on the steering column switch cluster. The slot features two Hall sensors.

One Hall sensor detects when the identification transmitter is inserted and locked in position. The other registers when the identification transmitter is ejected/removed.

The electric lock of the inserted identification transmitter is also located in the slot.

The car access system 2 evaluates the Hall sensors of the slot.



Car Access System 2 (CAS 2)

The car access system 2 is the master control unit for comfort access. The car access system 2 checks the requests triggered by the comfort access system.

For example, the car access system 2 enables activation of the central locking or of the electric steering column lock. The car access system 2 is also responsible for the engine start enable.

The CAS-bus is used for the communication between car access system 2 and comfort access.

The CAS-bus is a bus system based on the K-bus.

NOTES

PAGE

Car Access System Circuit Diagram

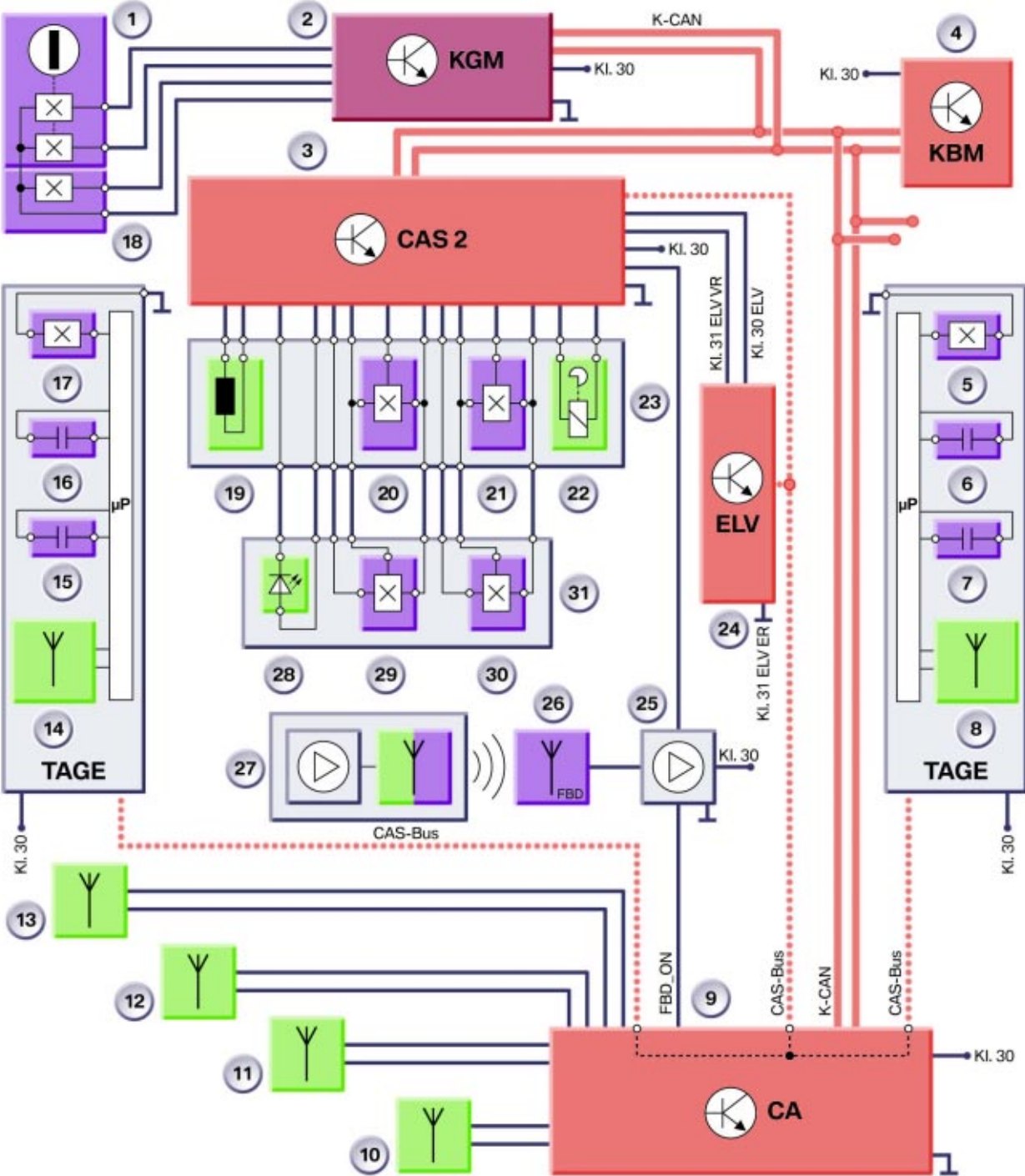

Legend for Car Access System Circuit Diagram

Index	Explanation	Index	Explanation
1	Driver's door lock barrel	21	Hall sensor, identification transmitter in slot
2	Body-gateway module KGM	22	Identification transmitter locked in slot
3	Car access system 2 CAS 2	23	Identification transmitter holder
4	Basic body module KBM	24	Electric steering lock ELV
5	Hall sensor "pull" TAGE passenger's side	25	Remote control antenna
6	TAGE capacitive sensor, front passenger's side	26	Remote control receiver
7	TAGE capacitive sensor, front passenger's side	27	Identification transmitter
8	TAGE antenna, front passenger's side	28	LED START/STOP button
9	Comfort access CA	29	Hall sensor, START/STOP button
10	Exterior antenna	30	Hall sensor, START/STOP button
11	Luggage compartment antenna	31	START/STOP button
12	Interior antenna, rear	CAS-	CAS-bus (K-bus protocol) Bus
13	Interior antenna, front Kl. 30	K-CAN	Body CAN
14	TAGE antenna, driver's side	KL 30	Terminal 30
15	TAGE capacitive sensor, driver's side	KL 30 ELV	Terminal 30 ELV (bus power supply)
16	TAGE capacitive sensor, driver's side Kl. 31	KL 31 ELV ER	Terminal 30 ELV unlock (ground connection)
17	Hall sensor "pull" TAGE driver's side	KL 31 ELV VR	Terminal 30 ELV lock (ground ELV VR connection)
18	Door contact	FBD	Remote control services
19	Transponder coil	FBD ON	Remote control services ON
20	Hall sensor, identification transmitter in slot	FBD OUT	Remote control services OUT

Central Locking

The central locking system is described in the following based on the example of the E60. The description briefly outlines the changes to the central locking system in the models E61, E63 and E64.

The central locking system is a distributed function. The control units that make up the system are the:

- CAS 2
- KGM
- KBM

The car access system 2 CAS 2 is the master for the central locking system. On vehicles with comfort access CA, this control unit is also involved in the central locking system.

Communication between CAS 2, KBM, KGM and CA takes place via the K-CAN.

Body Gateway Module (KGM)

With the aid of two double relays, the KGM controls the central locking of the front doors. The double relays are integrated in the KGM. The KGM registers the status of the central locking drive units and makes this status available via the K-CAN.

The statuses are:

- Central locking unlocked ER
- Central locking locked VR
- Central locking arrested (double locked)

The KGM evaluates the status of the door contacts (Hall sensors) in the front doors. The KGM makes available, via the K-CAN, the status of the door contacts to other users in the system network.

The status of the Hall sensors in the lock barrel of the driver's door is also evaluated by the KGM and sent via the K-CAN.

Relays for Central Locking

Because the KGM replace the individual front door modules in the E60/61, the relays for door lock actuation are located inside.

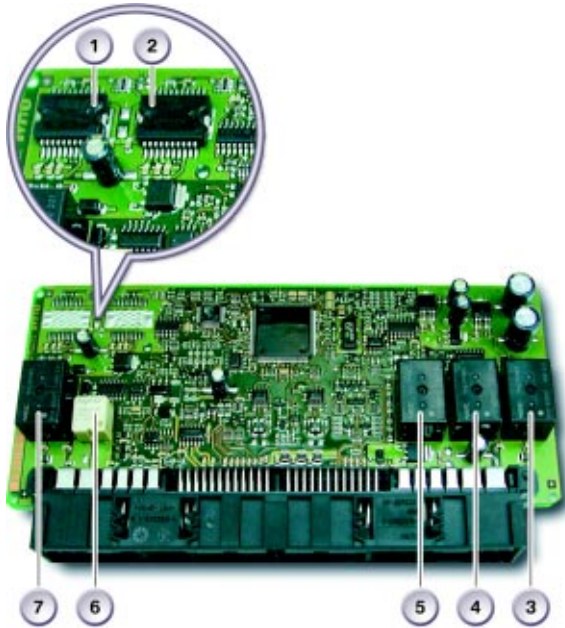

Relays in KGM

Index	Explanation
1	Output stage, outside mirror heating, driver's door
2	Output stage, outside mirror heating, passenger's door
3	Double relay for power window, passenger's door
4	Double relay for central arrest/locking, driver's door
5	Double relay for unlock/lock, passenger's door
6	Relay for terminal 30g_f
7	Double relay for power window, driver's door

Body Basic Module (KBM)

The basic body module KBM controls the central locking in the rear doors, fuel filler flap and boot lid/rear hatch.

On the E61 Touring, the KBM additionally controls the central locking for the rear window and load area cover.

The basic body module controls the central locking for the storage compartment in the center console of the E63 and E64.

Central Locking Circuit Diagram

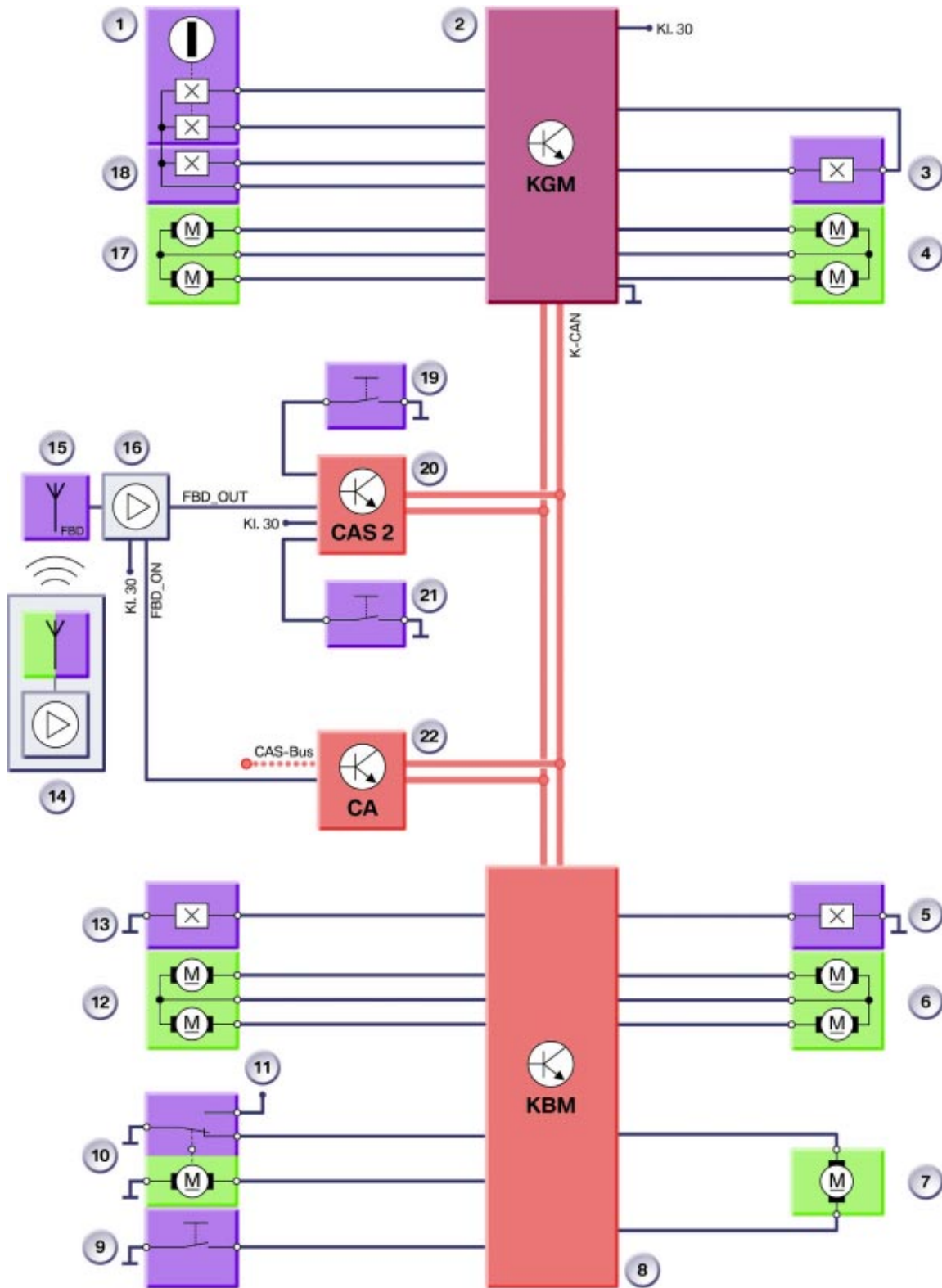

Legend for Central Locking Circuit Diagram

Index	Explanation	Index	Explanation
1	Driver's door lock barrel	15	Rear window antenna
2	Body-gateway module KGM	16	Remote control receiver
3	Door contact, passenger's door	17	Central locking, driver's door
4	Central locking, passenger's door	18	Door contact, driver's door
5	Door contact, rear passenger's side	19	Center-lock button
6	Central locking, rear passenger's side	20	Car access system 2 CAS 2
7	Central locking, fuel filler flap	21	Interior button for boot lid
8	Body basic module	22	Comfort access CA
9	Button, boot lid, exterior	K-CAN	Body CAN
10	Central locking, boot lid	KL 30	Terminal 30
11	Connection, luggage compartment lights	CAS bus	Car access system bus
12	Central locking, rear driver's side	FBD	Remote control services
13	Door contact, rear driver's side	FBD ON	Remote control services ON
14	Identification transmitter	FBD OUT	Remote control services OUT

Interior Lighting

Doors

Together with the interior lighting master, the KGM controls the light functions in the front doors. The master for the interior lighting is the basic body module. The KGM therefore receives the request to switch the door light functions on or off via the K-CAN.

The KGM is responsible for the following lighting systems:

- Door exit light
- Sill lighting on the E63
- Courtesy lighting
- Driver's door switch cluster

Door Exit Light

Depending on the coding of the KGM, the door exit lights can be switched on either via the Soft ON/Soft OFF function or directly. To avoid fluctuations in the brightness, the door exit lights are activated pulse-width modulated by means of driver output stages.

The KGM monitors the door exit lights for shorts to ground. A temperature protection facility is included in the driver output stages. A fault code is entered in the KGM as soon as the triggering temperature is reached.

Courtesy Light

The courtesy lighting in the outside mirror is controlled by the KGM via the LIN bus. The lighting can be switched on or off either via the Soft ON/Soft OFF function or directly.

The courtesy lighting is not activated at terminal 15 ON.

Sill Lighting E63

The sill lighting is connected in parallel to the output for the door exit light.

Driver's Door Switch Cluster

The buttons in the driver's door switch cluster are eliminated by means of locator lighting, terminal 58g or the function indicator.

The function lighting is based on the brightness value of the photosensor in the instrument cluster.

The instrument cluster makes available the brightness value via the K-CAN. In connection with the LIN-bus, the KGM controls the function lighting of a pressed button (e.g. child safety lock, "All windows" button E64).

Backlighting (terminal 58g)

Various lights in the front doors are operated directly by the lights module in connection with terminal 58g. These lighting functions are:

- Handle plate light
- Driver's door switch cluster
- Storage compartment light
- Passenger's power window switch

Power Windows

Front Windows

The control of the power windows is distributed over 3 control units. These control units are the CAS 2, KGM, and KBM.

The car access system CAS is the master control unit for the power window function.

Communication between CAS 2, KBM, and KGM takes place via the K-CAN.

The Convertible top module CVM makes further information available via the K-CAN for operation of the power windows on the E64.

Body Gateway Module (KGM)

The body-gateway module KGM evaluates the front power window switch on the passenger's side and the driver's door switch cluster. The following power window functions are integrated in the KGM:

- Control and monitoring of the direction of rotation of the power window motors in OPEN or CLOSED direction.
- Toll function
- Convenient opening and convenient closing
- Anti-trapping function
- Disabling power window operation at terminal 50.

Body Basic Module (KBM)

The basic body module KBM controls the power windows in the rear doors.

Convertible Top Module (CVM) E64

The KGM receives additional requests from the driver's door switch cluster, concerning the Convertible top system.

These requests are:

All windows and rear window OPEN or CLOSED (only E64 Convertible top module CVM)

- Rear window OPEN or CLOSED

The requests, e.g. OPEN or CLOSE rear window, are sent via the K-CAN to the CVM.

The CVM controls the movement of the rear window.

When opening or closing the convertible top, the KGM receives, via the K-CAN, the request to lower the windows from the CVM. The KGM completely lowers the front windows.

A closed side window reliably prevents draughts from the vehicle exterior. The window of the respective door is lowered when opening the driver's or passenger's door, thus allowing the doors to be opened.

The window is also closed after closing the door to again provide reliable protection against draughts.

Lowering the Side Window E63

As on the E64, the window is lowered slightly when the driver's or passenger's door is opened. The window is also closed after closing the door

The "easy entry" function can be set in the personal profile. After activating this function, the windows are opened by as much as 75% after unlocking twice within 2 seconds and after opening the door.

Outside Mirrors

Mirror Control

The mirrors are connected via the LIN-bus. The electronic mirror module controls the mirrors.

The signal progression for the driver's outside mirror is as follows:

- From the KGM via the LIN-bus to the driver's door switch cluster
- From the driver's door switch cluster via the LIN-bus to the electronic mirror module
- The electronic mirror module controls the mirror adjustment motors.

The signal progression for the passenger's outside mirror is as follows:

- From the KGM via the LIN-bus to the electronic mirror module
- The electronic mirror module controls the mirror adjustment motors.

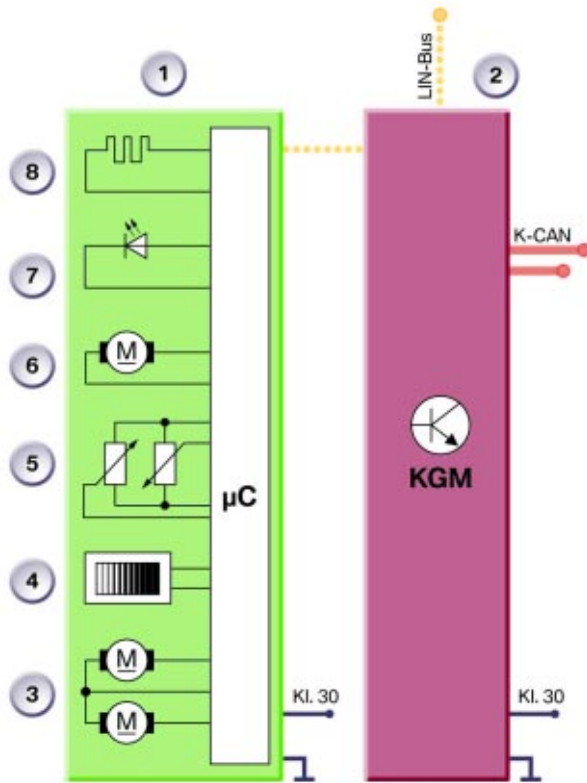

Index	Explanation
1	Outside mirror
2	Base Gateway Module
3	Motor for outside mirror adjustment
4	Electrochromic outside mirrors
5	Potentiometer, outside mirror memory
6	Outside mirror folding motor
7	Courtesy lighting
8	Mirror heating

Mirror Circuit Diagram

Mirror Heating

The KGM controls the mirror heating via the LIN-bus.

Mirror Folding Function

The KGM evaluates the mirror fold-in request and activates the fold-in motors via the LIN Bus.

The mirror folding function can be triggered manually using the convenient closing/opening function.

3 The convenient closing function can be coded. 1

Electrochromic Mirrors

The KGM receives the signal for the EC mirror function directly from the interior rear-view mirror. The KGM evaluates the signal from the interior rear-view mirror and forwards the request via the LIN-bus to the outside mirrors.

The electronic mirror module carries out the request.

Mirror Memory

The KGM evaluates the signals from the electronic mirror module and stores the value in the KGM.

Automatic Parking (curb viewer) Function

The passenger's side mirror is turned downward when reverse gear is engaged, thus providing a better view of the curb. The automatic parking function (curb viewer) is available together with the mirror memory.

Safety Gateway Module

The body-gateway module will be installed in the BMW 5 Series and BMW 6 Series as from 09/2005. It is connected via two 51-pin connectors to the system network and is installed in the units carrier behind the glove compartment.

The body-gateway module replaces the safety and gateway module, the door modules and the micro-power module.

Functional Integration

Due to the functional integration, the KGM is involved in various functions. These functions are listed in the following table:

Function/component	Replaced	New
Central locking		
<ul style="list-style-type: none"> Activation in front doors Evaluation of front door contacts Evaluation of Hall sensors in driver's door lock barrel 	byteflight , TMFA/TMBF and SGM	<ul style="list-style-type: none"> Activation of central locking in front doors by KGM Evaluation of front door contacts Evaluation of Hall sensors in driver's door lock barrel by KGM
Interior lighting, front		
<ul style="list-style-type: none"> Activation in front doors Evaluation of front door contacts 	byteflight , TMFA/TMBF and SGM	<ul style="list-style-type: none"> Activation of interior lighting in front doors by KGM Evaluation of front door contacts by KGM
Roller sun blind		
<ul style="list-style-type: none"> Activation 	byteflight between door module and SGM	<ul style="list-style-type: none"> Activation of roller sun blind by KGM Link of driver's door switch cluster via LIN-bus to KGM
Automatic climate control		
<ul style="list-style-type: none"> Gateway 	SGM	<ul style="list-style-type: none"> Gateway in KGM
Telephone		
<ul style="list-style-type: none"> Link of steering column switch cluster SZL and multifunction steering wheel 	byteflight between SZL and SGM	<ul style="list-style-type: none"> Link of steering column switch cluster and multifunction steering wheel via PT-CAN to KGM
Head-up display		
<ul style="list-style-type: none"> Gateway 	SGM	<ul style="list-style-type: none"> Gateway in KGM
Instrument cluster		
<ul style="list-style-type: none"> Gateway 	SGM	<ul style="list-style-type: none"> Gateway in KGM

Function/component	Replaced	New
Exterior lighting		
<ul style="list-style-type: none"> Signalling of requests from steering column switch for direction indicator, low beam and high beam 	byteflight between steering column switch cluster and SGM	<ul style="list-style-type: none"> PT-CAN between steering column switch cluster and KGM
Adaptive headlight		
<ul style="list-style-type: none"> Signalling of data from steering angle sensor in SZL 	byteflight between steering column switch cluster and SGM	<ul style="list-style-type: none"> PT-CAN between steering column switch cluster and KGM PT-CAN to lights module
Seats		
<ul style="list-style-type: none"> Memory function 	byteflight between steering column switch cluster and SGM	<ul style="list-style-type: none"> PT-CAN between steering column switch cluster and KGM Memory position of outside mirrors in KGM
Active backrest width adjustment		
<ul style="list-style-type: none"> Gateway 	SGM	<ul style="list-style-type: none"> Gateway in KGM
Steering column		
<ul style="list-style-type: none"> Steering column adjustment 	byteflight between steering column switch cluster and SGM	<ul style="list-style-type: none"> PT-CAN between steering column switch cluster and KGM
Steering column switch cluster		
<ul style="list-style-type: none"> Link to SZL 	byteflight between steering column switch cluster and SGM	<ul style="list-style-type: none"> Link of steering column switch cluster via PT-CAN to KGM

Function/component	Replaced	New
Front power windows		
<ul style="list-style-type: none"> • Power windows control • Evaluation of front door contacts • Evaluation of driver's door switch cluster • Evaluation of power window switch on passenger's side 	<p>byteflight, TMFA/TMBF and SGM</p>	<ul style="list-style-type: none"> • Activation of power windows in front doors by KGM • Evaluation of front door contacts by KGM • Evaluation of driver's door switch cluster by KGM • Evaluation of power window switch on passenger's side by KGM
Slide/tilt sunroof		
<ul style="list-style-type: none"> • Gateway 	SGM	<ul style="list-style-type: none"> • Gateway in KGM
Panoramic glass roof		
<ul style="list-style-type: none"> • Vehicle speed signal 	SGM	<ul style="list-style-type: none"> • Gateway in KGM
Anti-theft alarm system		
<ul style="list-style-type: none"> • Evaluation of front door contacts 	Door modules	<ul style="list-style-type: none"> • Evaluation of front door contacts by KGM
Wipe/wash system		
<ul style="list-style-type: none"> • Signalling of requests from steering column switch for wipe-wash system 	<p>byteflight between steering column switch cluster and SGM</p>	<ul style="list-style-type: none"> • PT-CAN between steering column switch cluster and KGM

Properties

The table below shows a selection of the specific properties of the KGM.

General control unit data	
Voltage range	The body-gateway module operates in the voltage range between 9 V and 16 V
Closed-circuit current	In sleep mode, the control unit has a current consumption of approx. 1 mA
Short-circuit-proof	The body-gateway module is short-circuit-proof with respect to terminal 30 and terminal 31
Polarity reversal protection	The body-gateway module is protected against polarity reversal.
Temperature range	The body-gateway module operates in a temperature range from -40 °C to +80 °C

Location



Control Unit Location

Index	Explanation	Index	Explanation
1	Comfort Access	4	Body Gateway Module (KGM)
2	Panoramic Sunroof (MDS)	5	CD Changer
3	Body Basic Module (KBM)		

Steering Column Switch Cluster

A new steering column switch cluster will be installed in the models E60/E61/E63 and E64 as from 09/2005. This steering column switch cluster represents a combination of technologies that are already familiar from various predecessor models:

- As on the E87/E90, the steering angle is acquired by optical means.
- As on the E60/E65 models, the steering column stalks are equipped with electric buttons.

The two control units previously responsible for this system (electronic steering wheel module LRE and electronic steering column module LSE) have been combined in one control unit (steering column switch cluster).



As on the E65/E60 models, the switch positions of the steering column stalks for wipers, direction indicators and cruise control are registered electrically and forwarded to the SZL control unit. The information from the switches and steering angle sensor are processed in the SZL control unit and transferred to other systems via the F-CAN or PT-CAN. The driver's airbag is connected to the ACSM control unit.

SZL System Circuit Schematic

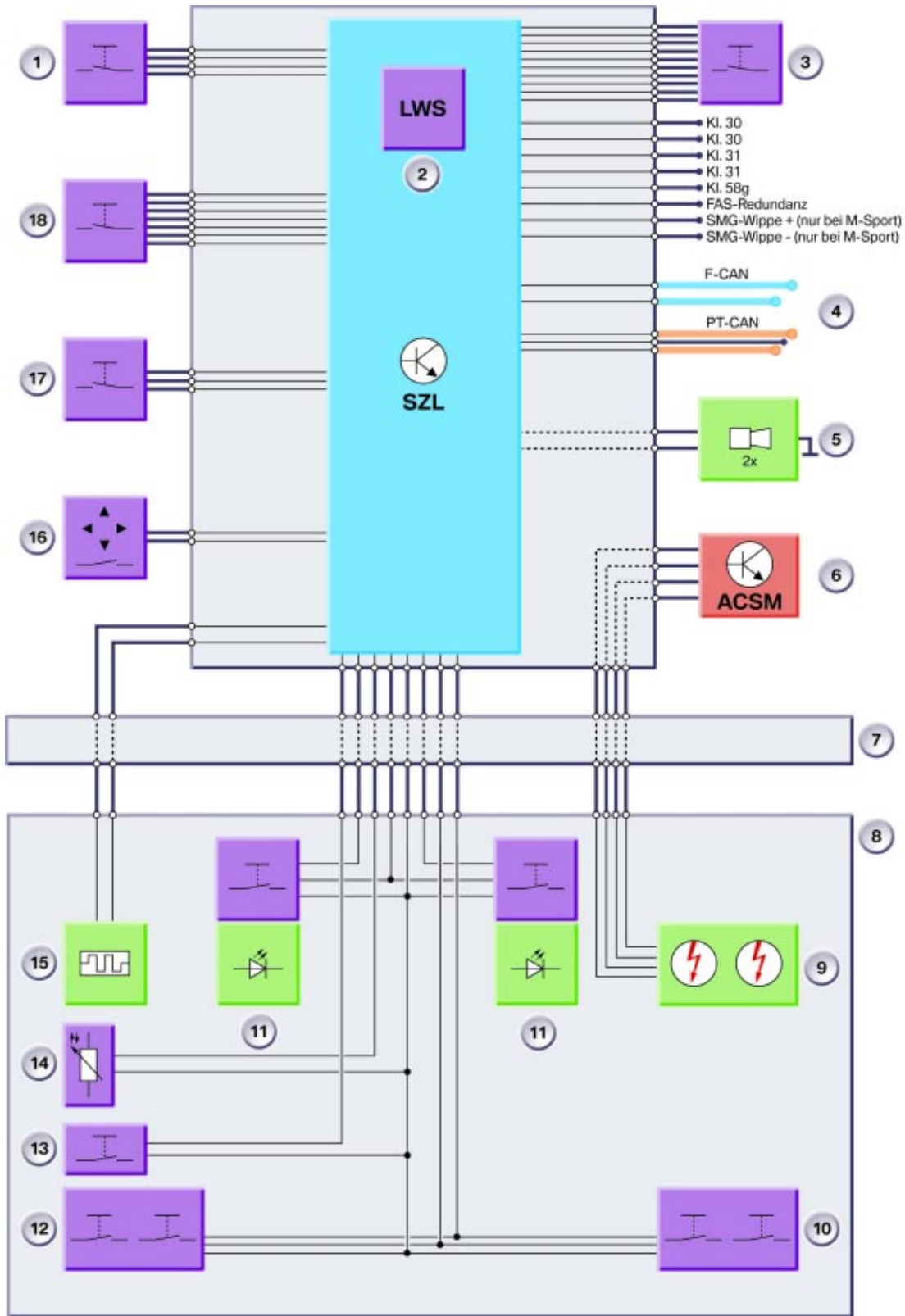

SZL System Circuit Schematic Legend

Index	Explanation	Index	Explanation
1	Steering column switch, direction indicator lights	15	Steering wheel heating
2	Steering column switch cluster with steering angle sensor	16	Switch for steering column adjustment
3	Steering column switch, wipers	17	Switch for steering wheel heating
4	Bus connections F-CAN and PT-CAN	18	Steering column stalk, cruise control
5	Horn 2x activation	19	Temperature sensor, steering wheel heating
6	Advanced safety and crash management	KL 30	Battery positive, load
7	Coil spring assembly	KL 30	Battery positive, electronics
8	Multifunction steering wheel	KL 31	Battery negative, load
9	2-stage driver airbag	KL 31	Battery negative, electronics
10	SMG button	KL 58g	Dimming information
11	Multifunction buttons	FAS redundancy	Redundant information, direction indicators
12	SMG button	SMG paddle +	Shift status, sequential manual gearbox, plus (only for M-Sport)
13	Horn button	SMG paddle +-	Shift status, sequential manual gearbox, minus (only for M-Sport)
14	Temperature sensor, steering wheel heating		

Note: The stalk switches used in the E6x updates are not optical sensors. They are conventional switched ground switches.

Component Overview

The steering column switch cluster consists of the following components:

- SZL control unit
- Steering angle sensor
- Steering column stalk, cruise control (FRA/ACC)
- Steering column switch, direction indicator stalk
- Steering column switch, wipers
- Coil spring assembly

The following components can be replaced separately:

- Steering column switch, cruise control
- Steering column switch, direction indicators
- Steering column switch, wipers
- Coil spring assembly
- SZL control unit with steering angle sensor

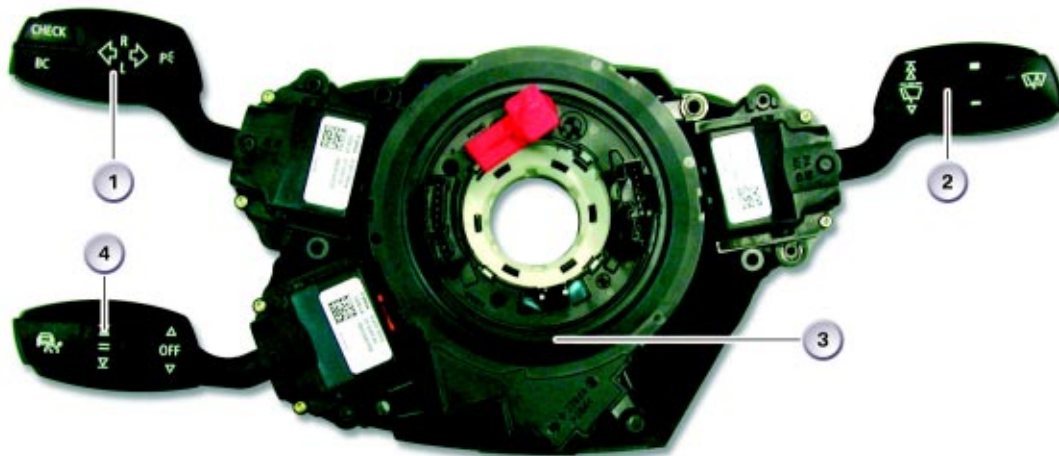

Index	Explanation	Index	Explanation
1	Steering column switch, direction indicator stalk	3	Coil spring assembly
2	Steering column switch, wipers	4	Steering column switch, cruise control

Electronic Steering Column Switch Cluster Module

The electronic steering column switch cluster module contains a processor, the power supply and following interfaces:

- F-CAN
- PT-CAN
- Electrical switches
- Horn
- SMG (M-Sport)
- Redundant lines for direction indicators

The optical sensor for measuring the steering angle is integrated in the pc-board of the control unit.

■ F-CAN Link

The SZL is connected via the F-CAN to the control units DSC and active steering AL. All necessary information relating to the running gear is made available via the F-CAN.

■ PT-CAN Link

In addition to the link to the F-CAN, the SZL also features an interface to the PT-CAN. Using this interface, the SZL control unit can send switch information (direction indicators, wipers, cruise control, multifunction steering wheel) to the corresponding control units.

The steering angle is also sent via the PT-CAN (e.g. direction indicator reset). All diagnosis and programming functions are performed via this data link.

■ SZL Power Supply

The SZL is connected to terminal 30. Only the steering angle sensor, the direction indicator steering column stalk and the switch for steering column adjustment are monitored every 300 ms in sleep mode. The closed circuit current is approx. 1 mA.



Index	Explanation
1	Plug-in connection for steering column stalk, cruise control
2	Optical sensor for steering angle
3	Plug-in connection for steering column stalk, direction indicator
4	Control unit for steering column switch cluster
5	Wiper steering column stalk, plug-in connection is located opposite side
6	Code disc

Control Unit for Steering Column Switch Cluster

Steering Angle Sensor

The steering angle sensor is designed as a contactless, optical angle measuring system.

The system consists of a code disc and an optical sensor. The code disc is connected via a drive element directly to the steering wheel. The code disc turns within the optical sensor when the steering wheel is moved.

Steering Column Switches

As on the E65/E60, the steering column switches are designed as electrical switches, which include switching mats and microswitches.

Differing from the predecessor models, the connectors to the SZL control unit have been modified.



Coil Spring Assembly

The coil spring assembly can be replaced only as a complete unit. The task of the coil spring is to transmit the following electrical signals from and to the multifunction steering wheel:

- Activation of driver airbag
- SMG control buttons
- Multifunction buttons
- Horn and steering wheel heating



■ Locking

To avoid damaging the coil spring assembly, it must be set to the correct position when dismantling the steering wheel and coil spring assembly.

The front wheels and steering wheel must be set to the straight-ahead position as the prerequisite for disassembly. During disassembly of the steering wheel, the load on the lock pin of the coil spring assembly is relieved and the pin can lock in the straight ahead position.

When the steering wheel is reinstalled, this arrangement ensures that the coil spring is not damaged when the steering wheel is turned to full left and right lock.

Functions

The functions of the steering column switch cluster are:

- Detecting steering angle and steering speed
- Detecting the controls in the multifunction steering wheel (volume, mDrive, etc.)
- Detecting switching signals from the steering column switches
- Sending and receiving information to/from the interlinked control units
- Activating steering wheel heating
- Reading switch for steering column adjustment
- Reading buttons, SMG paddles
- Reading horn button and activating horns.

Detecting Steering Angle

The steering column switch cluster must detect the steering angle and steering speed information as the basis for calculating various functions in the DSC.

Further information such as the absolute steering angle or the steering wheel rotation information is calculated. A steering angle of $-180^{\circ}/+180^{\circ}$ is detected.

An LED and fibre optics unit illuminate the code disc from above. Due to the pattern on the code disc, the light from above reaches the bottom only in certain areas where the light beams hit the line camera. This process is similar to scanning bar codes on packages/goods purchased.

The line camera converts the line signals into electrical signals and transfers them to the SZL.

Section of Code Disc

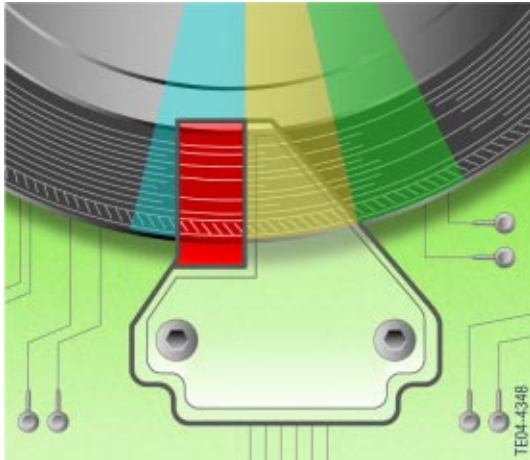

The code disc rotates dependent on the steering wheel angle setting. The pattern on the code disc changes in steps of 2°.

Optical Sensor

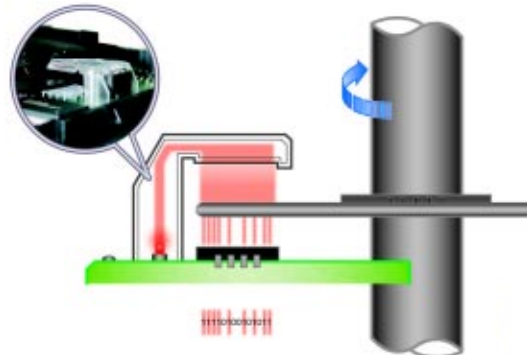

The light beams hit the line camera. The light pulses are converted to electrical pulses in the line sensor.

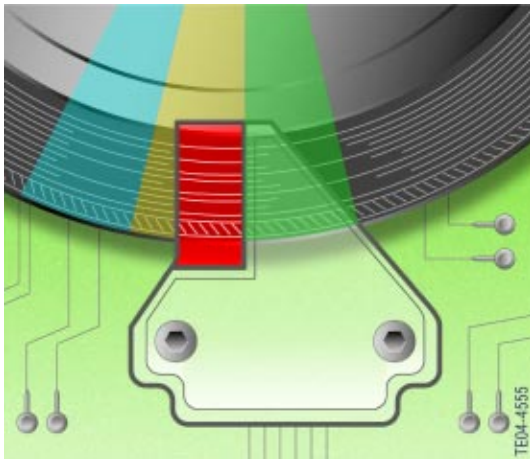

The pattern on the code disc changes as the disc continues to turn. The light passes through the code disc into other areas.

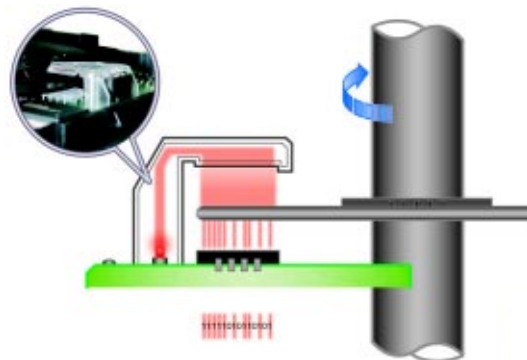

The position of the light beams is displaced. The line camera detects the light beams in other areas and transfers the information to the SZL.

Relative Steering Angle

The relative steering angle indicates the angle position of the steering wheel. The information relating to the relative steering angle is always retained even when power to the control unit is disconnected. Renewed zero adjustment is necessary only after the steering column switch cluster SZL has been replaced.

Absolute Steering Angle

The absolute steering angle is a calculation based on the relative steering angle and steering wheel rotation information. The absolute and relative steering angles are defined during the SZL initialization procedure. The SZL detects each position of the steering wheel over the entire steering lock range.

The precondition for the initialization procedure is that the wheels and steering wheel are set in the straight-ahead position.

Steering Wheel Rotation Information

The steering wheel rotation information indicates the turn position of the steering wheel.

The steering wheel rotation information is determined automatically by a virtual calculation model.

If lost, e.g. if power to the SZL is disconnected, this information must be taught-in again.

The steering column switch cluster SZL uses data from the speed sensors of the front wheels for the calculation. The SZL assumes the vehicle is driving straight ahead at constant speeds and therefore detects its zero position. The minimum speed necessary for this purpose is 20 km/h.

This process need not be initialized via the BMW diagnosis system. The SZL automatically determines the steering wheel rotation information as soon as the vehicle exceeds the minimum speed.

Problems may occur in calculating the steering wheel rotation information under Unfavorable road conditions (icy road surfaces). The DSC sends a corresponding CC message in this case.

Detecting the Controls of the MFL

The voltage signals of the buttons on the multifunction steering wheel are routed via the coil spring to the steering column switch cluster SZL. The SZL evaluates the voltage signals and sends the information to the corresponding control units.

The connections of the driver's airbag are wired via the coil spring directly to the corresponding control units. This information is therefore not evaluated in the SZL.