

# E60 Car Access System CAS System overview

## - Input/Output

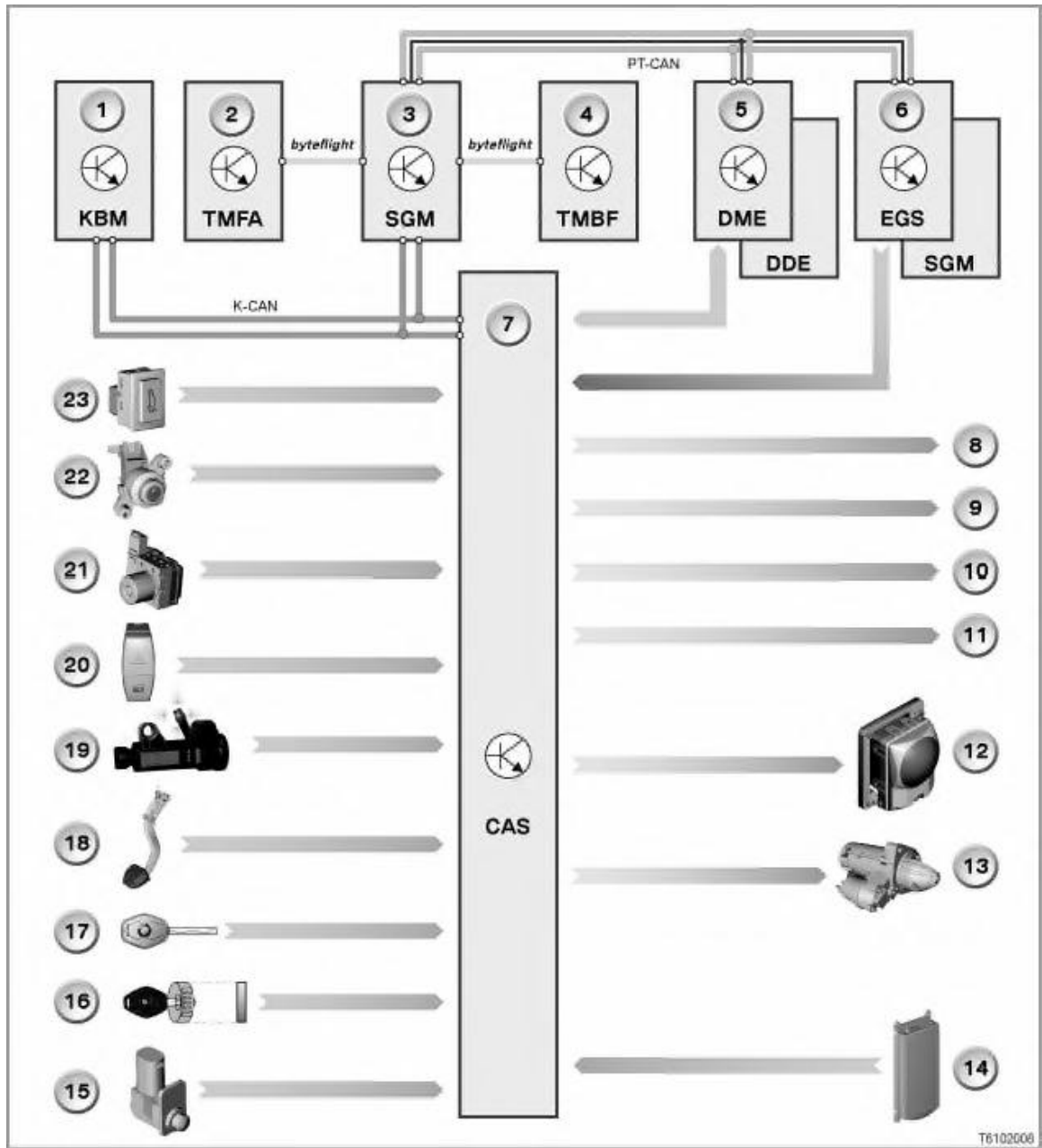

Key	Description	Key	Description
1	Body basic module KBM	2	Driver's door module TMFA
3	Safety and gateway module SGM	4	Front-passenger door module TMBF
5	Digital Engine Electronics DME or Digital Diesel Electronics DDE	6	Electronic transmission control EGS
7	Car Access System CAS	8	Terminal 15 output Wake-up line for PT CAN
9	Terminal 30g output	10	

			Terminal 15 output for OBD socket, light module, relay for fuel heater on vehicles with DDE or relay for injection valves on vehicles with DME
11	Terminal R output for brake light switch, clutch switch (with manual transmission), front-passenger side seat-occupancy detector	12	Terminal 15 output wake-up line for ACC
13	Terminal 50 starter	14	Input from telephone control unit, wake-up line for the MOST
15	Bonnet contact switch	16	Ignition starter switch with ring antenna
17	Remote control (via FBD receiver)	18	Brake light switch
19	Clutch switch (vehicles with manual transmission)	20	Central locking button
21	Speed signal from DSC	22	Boot lid lock cylinder (for the hotel position)
23	Interior boot lid pushbutton in the driver's footwell (US and Japan)		

**- System circuit diagram**

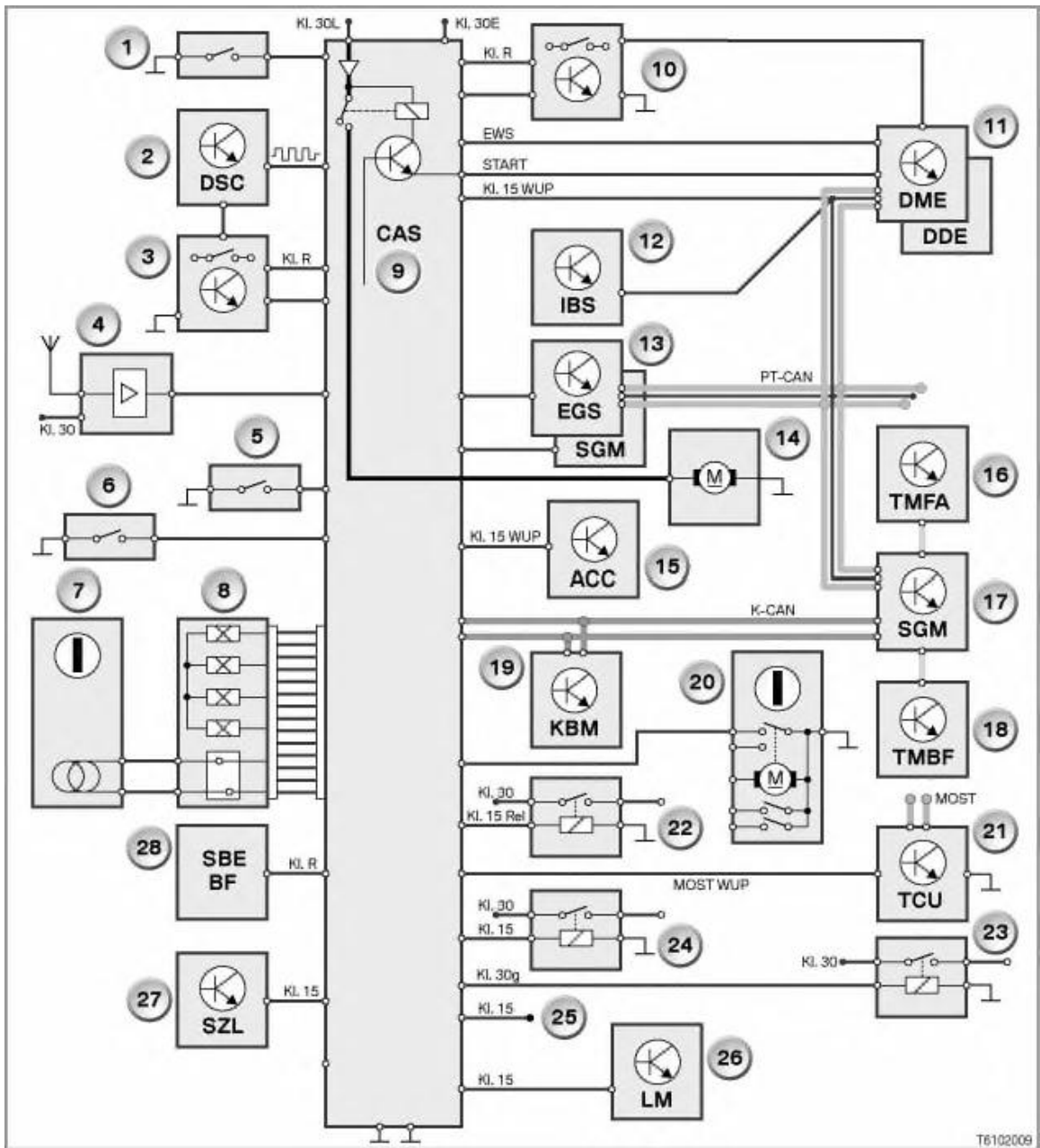

T6102009

Key	Description	Key	Description
1	Bonnet contact switch	2	Speed signal from the DSC
3	Brake light switch	4	FBD receiver (FBD= remote control service) for the signals from the remote control
5	Central locking button	6	Interior boot lid pushbutton in the driver's footwell (US and Japan)
7	Ring antenna in the ignition starter switch	8	Ignition starter switch
9	Car Access System CAS	10	Clutch switch (for US starter inhibitor on vehicles with manual transmission)
11	Digital Engine Electronics DME or Digital Diesel Electronics DDE	12	Intelligent battery sensor

13

	Electronic transmission control EGS or sequential transmission SMG	14	Terminal 50 starter
15	Terminal 15 output wake-up line for adaptive cruise control ACC	16	Driver's door module TMFA
17	Safety and gateway module SGM	18	Front-passenger door module TMBF
19	Body basic module KBM	20	Boot lid lock cylinder (hotel position)
21	Telephone control unit (e.g. TCU = Telematic Control Unit) for waking up the MOST on K CAN	22	Relay for terminal 15
23	Relay for terminal 30g	24	Relay for fuel heater on vehicles with DDE or relay for injection valves on vehicles with DME
25	Terminal 15 for the on-board diagnosis socket	26	Terminal 15 for the light module
27	Terminal 15 for steering column switch cluster SZL	28	Terminal R for front-passenger side seat-occupancy detector