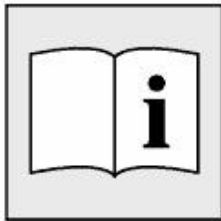
**Special tools required:**

- 11 9 470
- 11 9 472
- 11 9 473
- 11 9 474
- 11 9 475
- 11 9 480
- 11 9 490

(cylinder bank 1 to 4)

**Removal**

Removal of intermediate levers is described separately from installation.

Remove servomotor for right eccentric shaft.

Remove ignition coils on cylinder bank 1 to 4.

Remove right cylinder head cover.

Remove spark plugs on cylinder bank 1 to 4.

Remove inlet and exhaust adjustment unit on right side.

**Important!**

The inlet camshaft must first be rotated so that when the bearing bracket is removed the intermediate levers do not slip out and damage the camshaft.

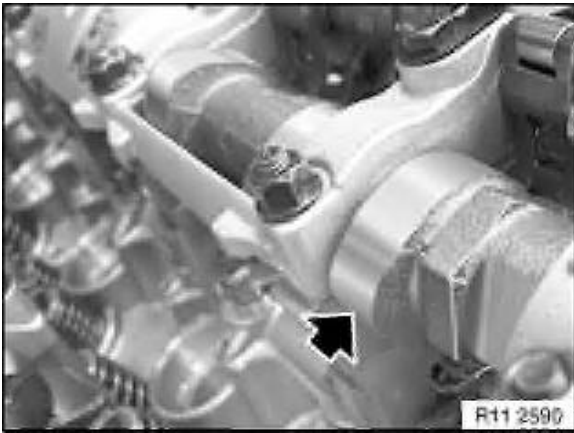

Rotate inlet camshaft in direction of rotation until cam on 1st cylinder is positioned horizontally as shown in illustration.

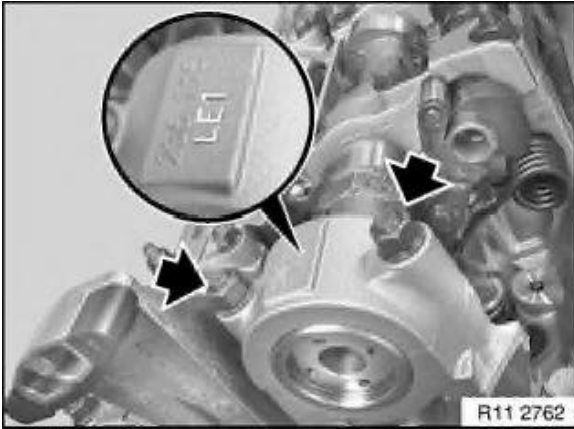

Important!

Do not mix up the camshaft bearing covers of cylinders 1 to 4 and 5 to 8.

Note:

Bearing caps of inlet camshaft are marked on cylinder bank 1 to 4 with L E1 to L E5 from inlet side.

Release nuts and remove bearing cap L E1.

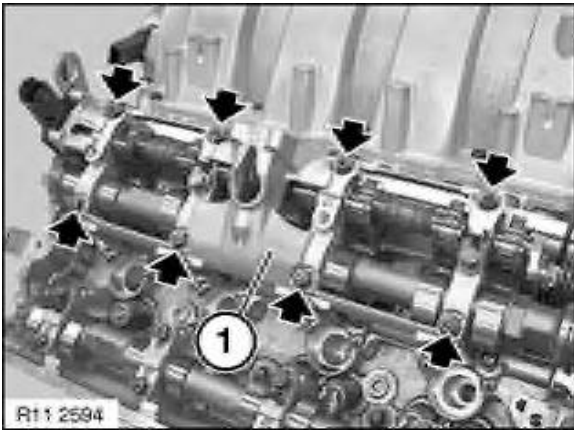

Release 8 nuts of bearing bracket (1) from outside to inside.

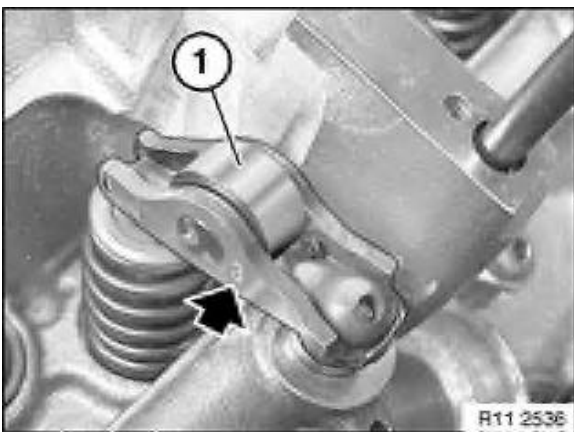

Note:

Rocker arms are freely accessible after bearing bracket has been removed.

Do "not" remove rocker arm (1) on inlet side.

Important!

Rocker arms (1) are divided into individual tolerance classes.

The tolerance classes are designated as illustrated with the numbers from 1 to 4.

Used rocker arms (1) may only be reused in the same position.

When replacing rocker arms (1) on inlet side: install rocker arms of the same tolerance class in the same position.

Clamp special tool 11 9 470 as illustrated in a vise.

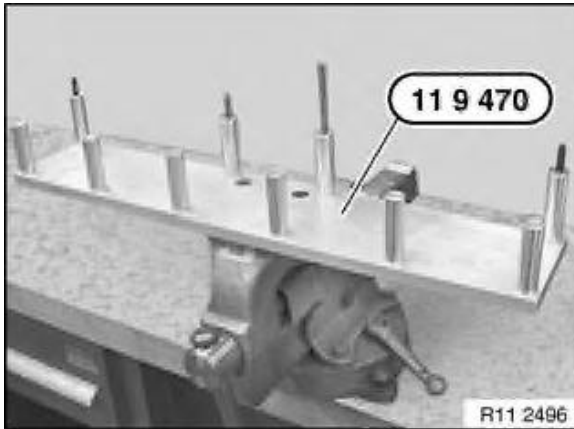

Important!

Do not tilt bearing bracket (1).

Carefully lift out bearing bracket (1).

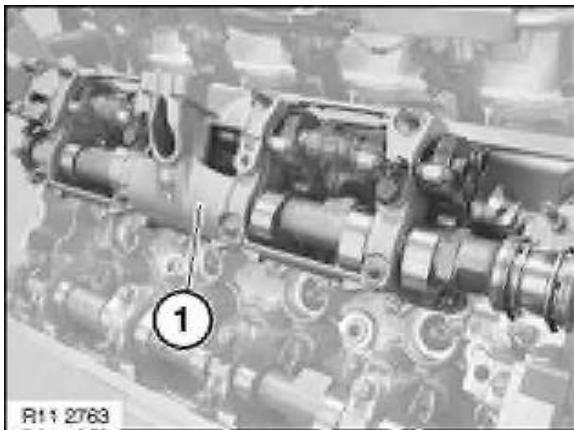

Place bearing bracket (1) with inlet camshaft and eccentric shaft as illustrated on special tool 11 9 470 .

Secure bearing bracket (1) with a nut (special tool 11 9 473).

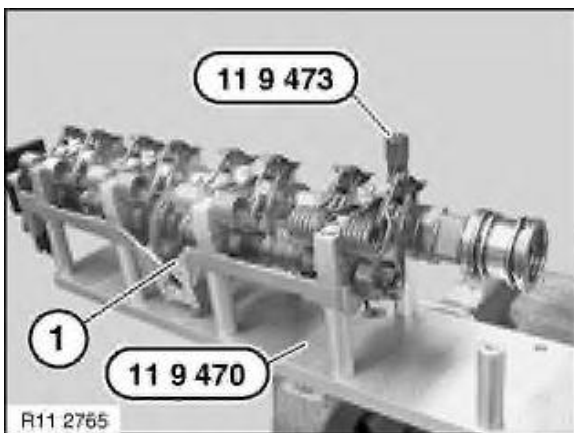

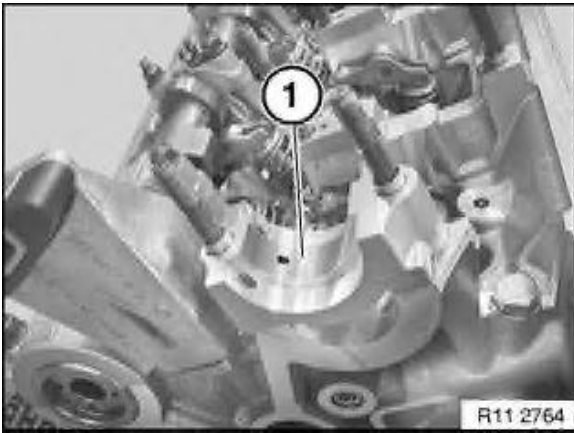

Important!

The lower section of the bearing bracket (1) is machined with the cylinder head and must not be mixed up.

Note:

Lower section of bearing bracket (1) remains on cylinder head.

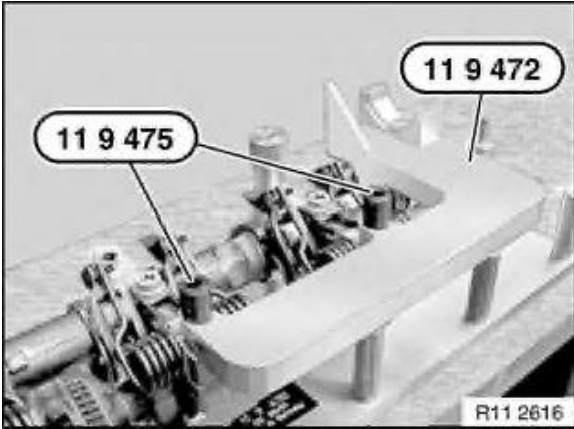

Note:

The mounting of the bearing bracket described later can only be carried out if the inlet camshaft has not been axially displaced. Special tools 11 9 472 and 11 9 475 prevent the inlet camshaft from rotating and moving while the intermediate levers are installed.

Fit special tool 11 9 472 and secure with special tool 11 9 475 .

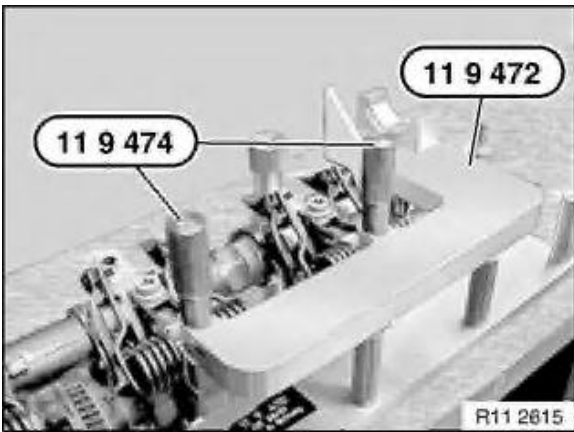

Insert special tool 11 9 474 and initially tighten without play.

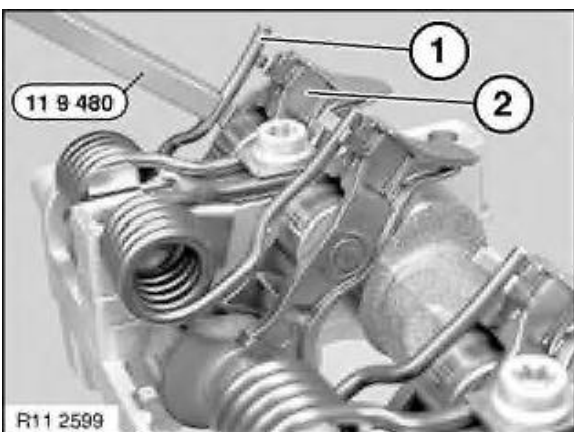

Note:

Removal of intermediate levers is described on 4th cylinder. The same procedure is applicable to cylinders 1 to 3.

Raise one end of torsion spring (1) with special tool 11 9 480 .

Lift out intermediate lever (2) and set down in an orderly fashion.

Important!

Keep holding torsion spring (1) with special tool 11 9 480 .

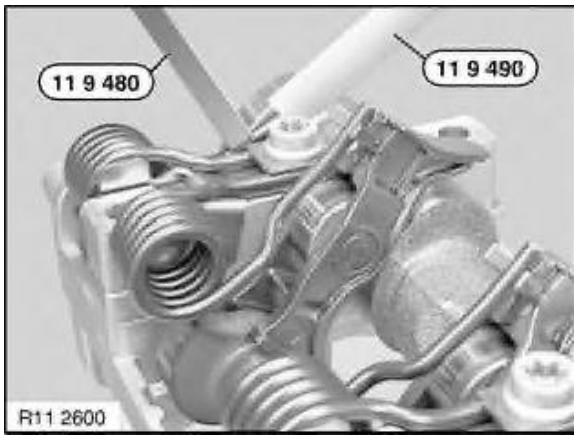

Attach special tool 11 9 490 to end of torsion spring.
Support end of torsion spring protected with special tool 11 9 490 on inlet camshaft.

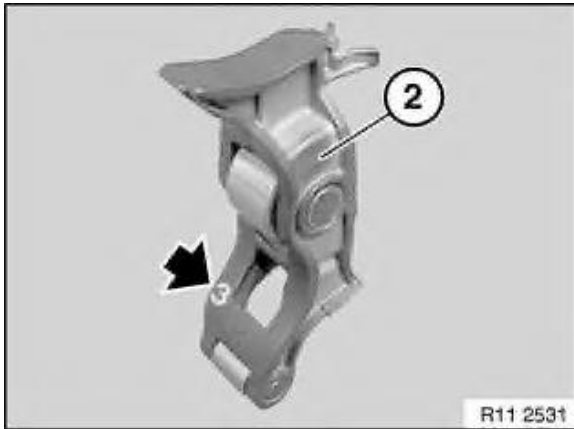

Important!

Intermediate levers (2) are divided into individual tolerance classes.
Only intermediate levers of the same tolerance class may be fitted in a single cylinder head.
The tolerance classes are designated as illustrated with the numbers from 1 to 5.
Used intermediate levers (2) may only be reused in the same position.

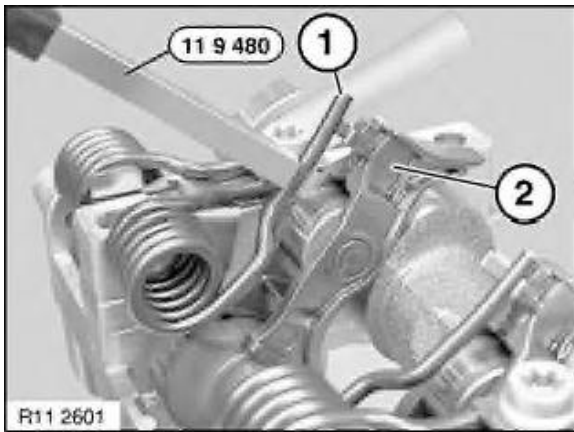

Raise second end of torsion spring (1) with special tool 11 9 480 .
Lift out intermediate lever (2) and set down in an orderly fashion.

Important!

Keep holding torsion spring (1) with special tool 11 9 480 .

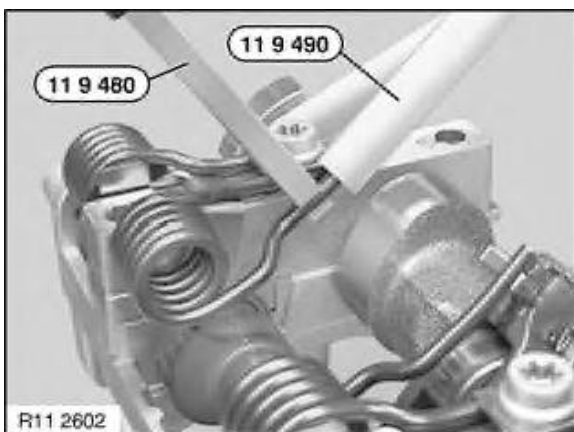

Attach special tool 11 9 490 to second end of torsion spring.
Support end of torsion spring protected with special tool 11 9 490 on inlet camshaft.

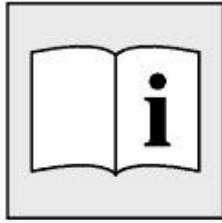

Installation

Removal of intermediate levers is described separately from installation.

Clean all bearings and cams of inlet camshaft and lubricate with engine oil.

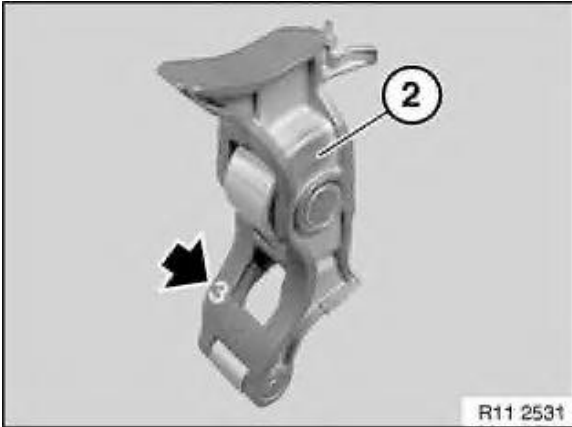

Important!

Intermediate levers (2) are divided into individual tolerance classes.

Only intermediate levers of the same tolerance class may be fitted in a single cylinder head.

The tolerance classes are designated as illustrated with the numbers from 1 to 5.

Used intermediate levers (2) may only be reused in the same position.

Lubricate all sliding surfaces on intermediate lever (2) with engine oil.

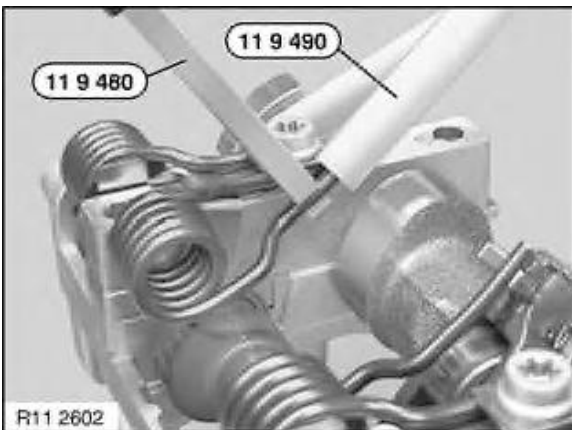

Raise torsion spring (1) with special tool 11 9 480 .

Detach special tool 11 9 490 .

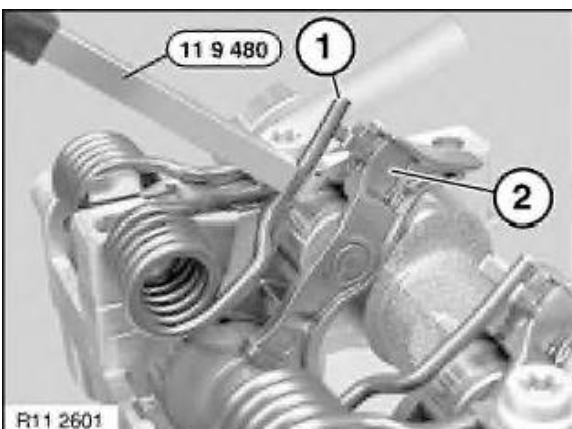

Hold torsion spring (1) with special tool 11 9 480 .

Install intermediate lever (2) from above.

Insert end of torsion spring (1) into guide on intermediate lever (2).

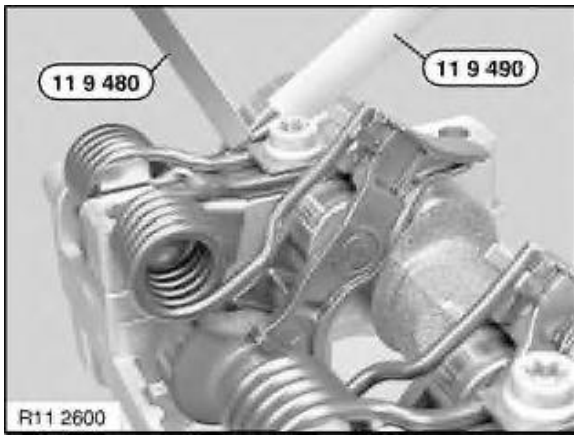

Raise second end of torsion spring with special tool 11 9 480 .
 Detach special tool 11 9 490 .

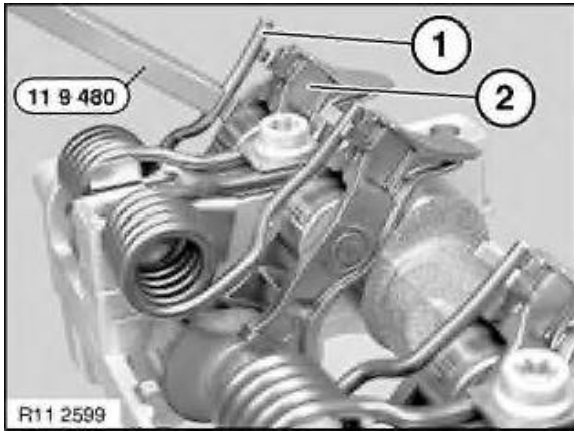

Hold torsion spring (1) with special tool 11 9 480 .
 Install intermediate lever (2) from above.
 Insert end of torsion spring (1) into guide on intermediate lever (2).

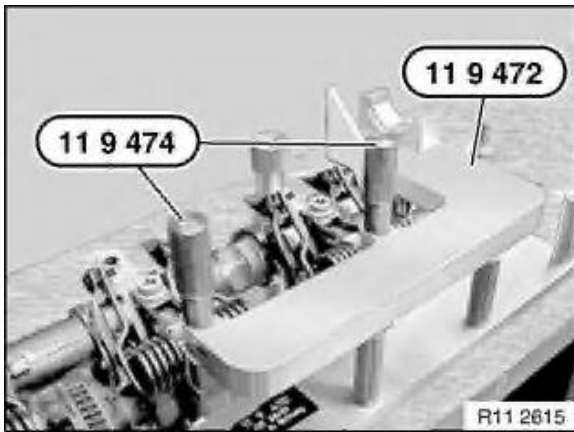

Remove special tool 11 9 474 .

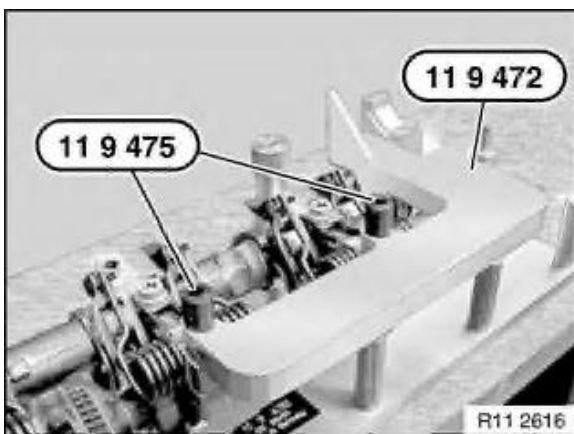

Remove special tools 11 9 472 and special tools 11 9 475 .

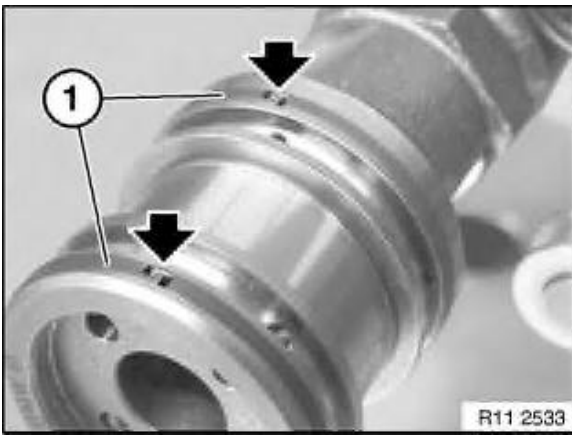

Ends of compression rings (1) point upwards.
Make sure compression rings (1) are engaged at ends.

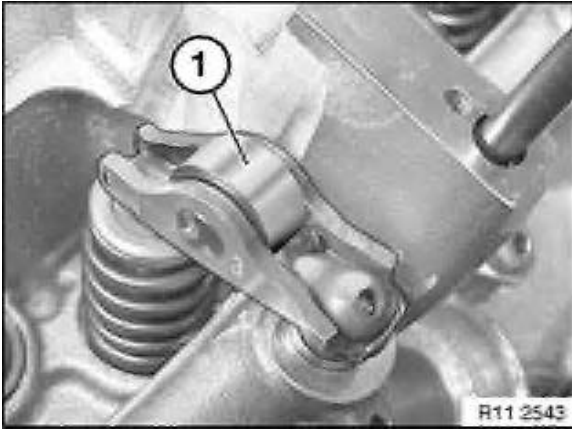

Important!

Rocker arms (1) slip slightly when bearing bracket is fitted.
Make sure rocker arms (1) are secured as illustrated on hydraulic valve clearance compensating elements and on valves.

Align rocker arms (1) straight.

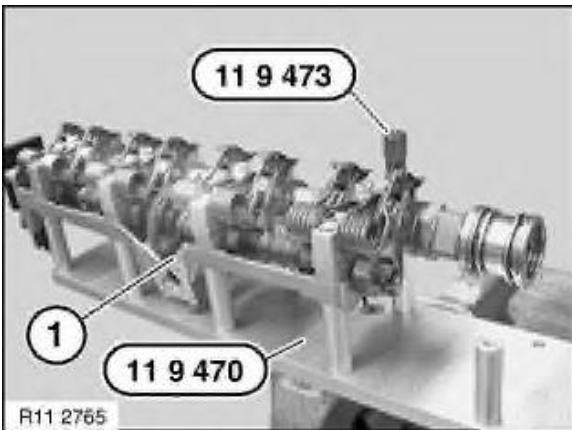

Remove special tool 11 9 473 .

Remove bearing bracket (1) from special tool 11 9 470 .

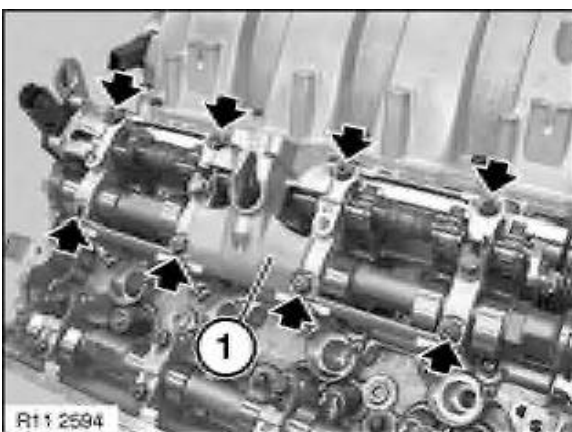

Important!

Do not tilt bearing bracket (1).

Lower bearing bracket (1) from above and carefully bring into contact with cylinder head.

Insert nuts and tighten by hand without play.

Important!

Make sure none of the intermediate levers or rocker arms have slipped out.

Tighten down nuts from inside to outside.

Tightening torque 11 31 1AZ .

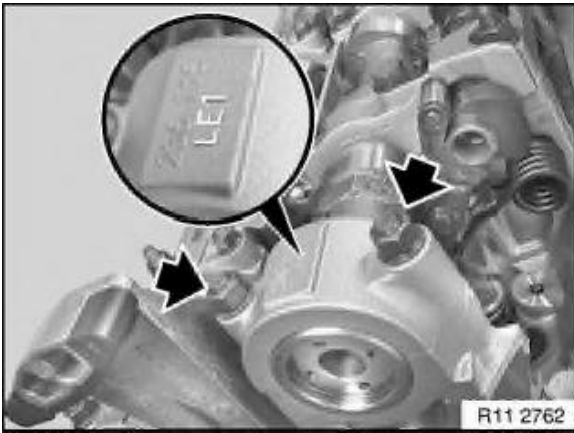

Important!

Do not mix up the camshaft bearing covers of cylinders 1 to 4 and 5 to 8.

Fit bearing cap L E1 in such a way that marking is legible from inlet side.

Install nuts and tighten down.

Tightening torque 11 31 1AZ .

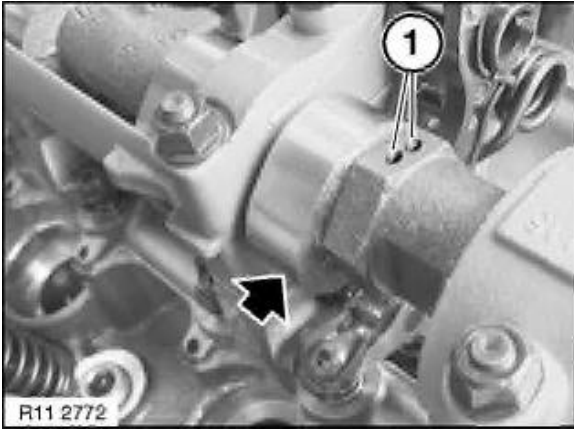

Rotate inlet camshaft at hexagon head against direction of rotation until cam on 1st cylinder points downwards at an angle as shown in illustration.

Note:

The marking (1) on the hexagon drive of the inlet camshaft faces upwards.

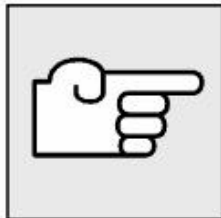

Install inlet and exhaust adjustment unit on right side.

Install spark plugs on cylinder bank 1 to 4.

Install right cylinder head cover.

Install ignition coils on cylinder bank 1 to 4.

Install servomotor for right eccentric shaft.

Assemble engine.