



This Service Information bulletin supersedes SI B51 02 05 **dated February 2007**.

**NEW** designates changes to this revision

## SUBJECT

### Squeaking Noise from Door Frame Area While Driving

## MODEL

E60, E61 (5 Series)

## SITUATION

Some customers may complain of hearing squeaking or creaking noises coming from the door frame area when driving on rough roads.

## CAUSE

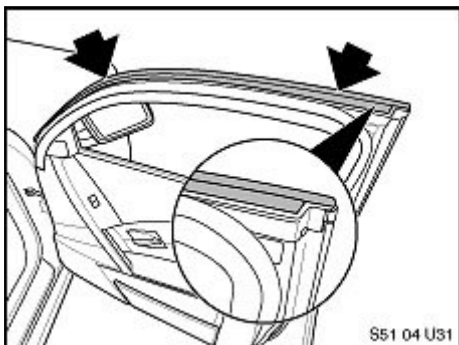

Movement between the flocking material (felt-like material indicated by the arrows) on the upper door seal and the surrounding roof panel may produce squeaking or creaking noises. These noises may be amplified by contamination or cleaner residue on the door opening.

## CORRECTION

**In the case of a customer complaint**, refer to the procedure outlined below to replace the seals with improved parts and/or apply the specified transparent Teflon tape.

The flocking material was changed in 01/2005 to an improved material with exceptional rigidity, strength, and low moisture absorption.

The new and improved parts may not have any unique identifying stamps or markings. Therefore, the production date should be used to identify the new seals.

Updated seals will have a date stamp on the back of the part reading later than January 3, 2005 (3.1.2005).

## PROCEDURE

Depending on the status of the vehicle, perform the applicable procedure described below.

- A. Vehicles produced up to 01/2005 - first complaint:
  - Replace all 4 upper door seals with the improved parts.

- Follow Repair Instruction RA 51 21 360 to replace the front upper door seals.
- Follow Repair Instruction RA 51 22 360 to replace the rear upper door seals.
- Thoroughly clean the upper door seal's mating surface on the body of the vehicle with a silicone remover, such as 3M General Purpose Adhesive Cleaner or Wurth Silicone Remover.
- Do not apply "Carbaflo" on these door seals.

B. Vehicles produced from 01/2005 and vehicles that have previously had the improved seals installed:

- Thoroughly clean the upper door seal's flocking material, as well as the mating surface on the body of the vehicle with a silicone remover such as 3M General Purpose Adhesive Cleaner or Wurth Silicone Remover.

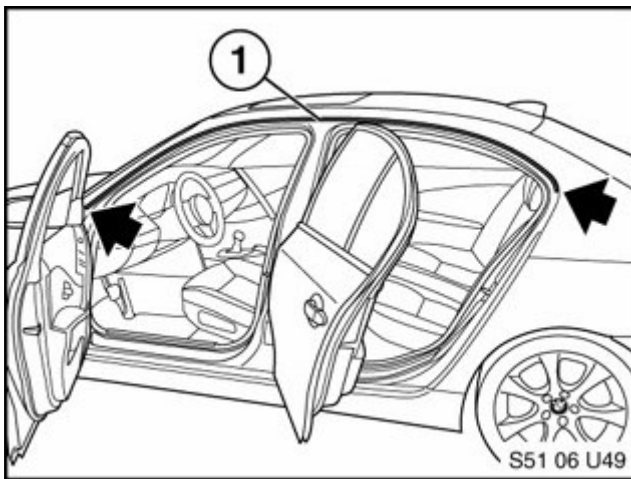

- Apply a continuous length of Teflon tape (PN 9 407 798) to the contact area of the flocking material (1) on the body of the vehicle.
- The area which the tape should be applied to spans from the middle of the A-pillar to the rear-most point on the rear door opening, as indicated by the arrows.

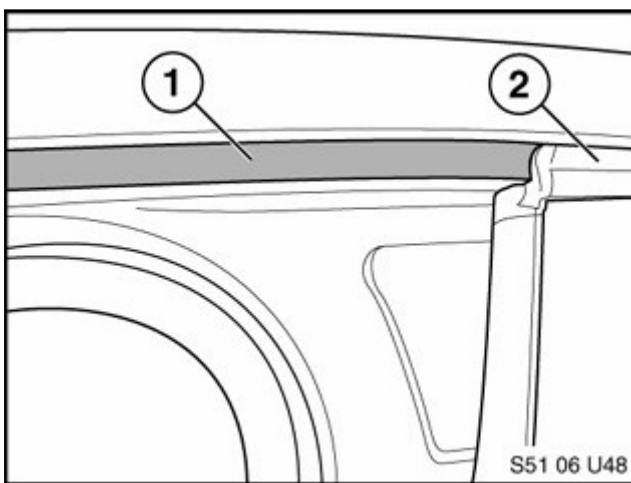

Notes:

The tape should be applied slowly and very carefully to avoid trapping air bubbles under the tape. To eliminate visibility of the tape when the door is closed and ensure proper contact with the flocking surface, the upper edge of the tape (1) should line up evenly with the top of the door seal (2) for the entire length of the applied area. The tape should be applied in its full width (16mm) and not be cut down to a narrower width.

C. Vehicles produced up to 01/2005 which are in for a repeat complaint and have the original seals installed:

- Replace all 4 upper door seals as per procedure A.
- Apply Teflon tape as per procedure B.

#### PARTS INFORMATION

| Part Number     | Description           | Quantity |
|-----------------|-----------------------|----------|
| 51 21 7 057 507 | Left front door seal  | 1        |
| 51 21 7 057 508 | Right front door seal | 1        |
| 51 22 7 057 509 | Left rear door seal   | 1        |
| 51 22 7 057 510 | Right rear door seal  | 1        |
| 83 19 9 407 798 | Teflon adhesive tape  | 1        |

3M General Purpose Adhesive Cleaner may be used for this procedure.

For more information on this product, please visit [www.3M.com](http://www.3M.com).

Würth Silicone Remover may also be used for this procedure.

For more information on this product, please visit [www.wurthusa.com](http://www.wurthusa.com).

#### WARRANTY INFORMATION

Covered under the terms of the BMW New Vehicle Limited Warranty.

**Defect Code**      **51 71 00 39 00**

Labor Operation:    Refer to KSD

Labor Allowance:    Refer to KSD

Labor Operation:    51 99 00            Work time to prepare surface and install Teflon tape

Labor Allowance:    3 FRU

**NEW** A reimbursement of up to \$47 may be charged to sublet code 4 for the Teflon tape (P/N 83 19 9 407 798) required to perform the repair noted above. Claiming this part number outside of sublet code 4 will result in a delayed or denied claim payment.