

- Inputs/outputs

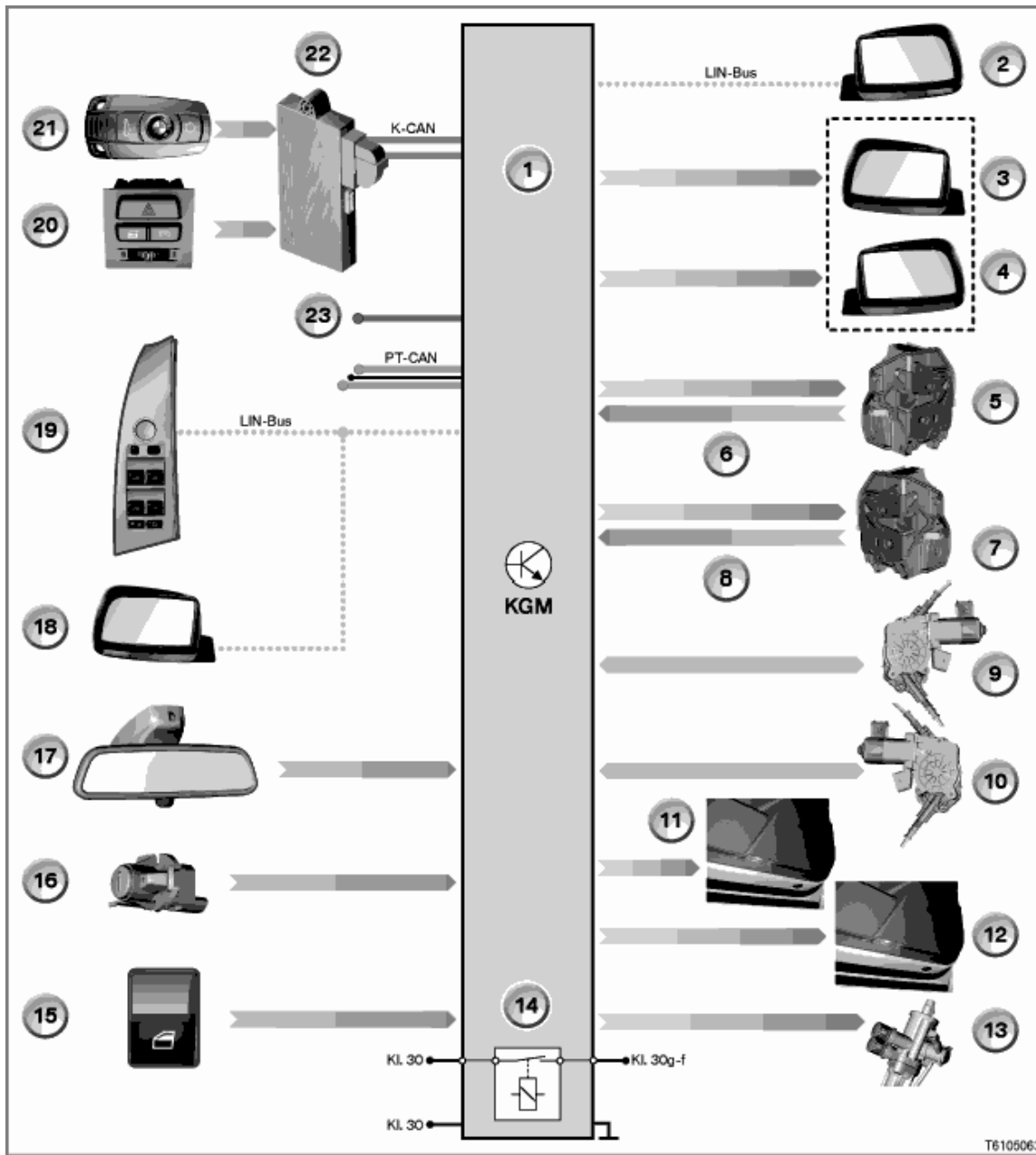

Item	Description	Item	Description
1	Body-gateway module (KGM)	2	Outside mirror with extended functions (passenger's side)
3	Basic outside mirror (driver's side)	4	Basic outside mirror (passenger's side)
5	Central locking drive in driver's door	6	Door contact in the driver's door
7	Central locking drive in passenger's door	8	Door contact in the front passenger door
9	Power-window motor in the driver's door	10	Power-window motor in the front passenger door
11	Door entry light in driver's door	12	Door entry light in passenger's door
13	Servotronic valve	14	Bistable relay

15

	Power-window switch in the front passenger door	16	Driver's door lock cylinder
17	Electrochromic rear-view mirror	18	Outside mirror with extended functions (driver's side)
19	Switch block in the driver's door	20	Central locking button
21	Remote control with integrated key	22	Car Access System (CAS)
23	Diagnostic wire		
Kl. 30	Terminal 30 (power supply)	Kl. 30g-f	Terminal 30 g-f (shut-down for closed-circuit current violation)
K-CAN	Body CAN	LIN-bus	Local data bus (Local Interconnect Network Bus)
PT CAN	Powertrain CAN		

**- System circuit diagram**

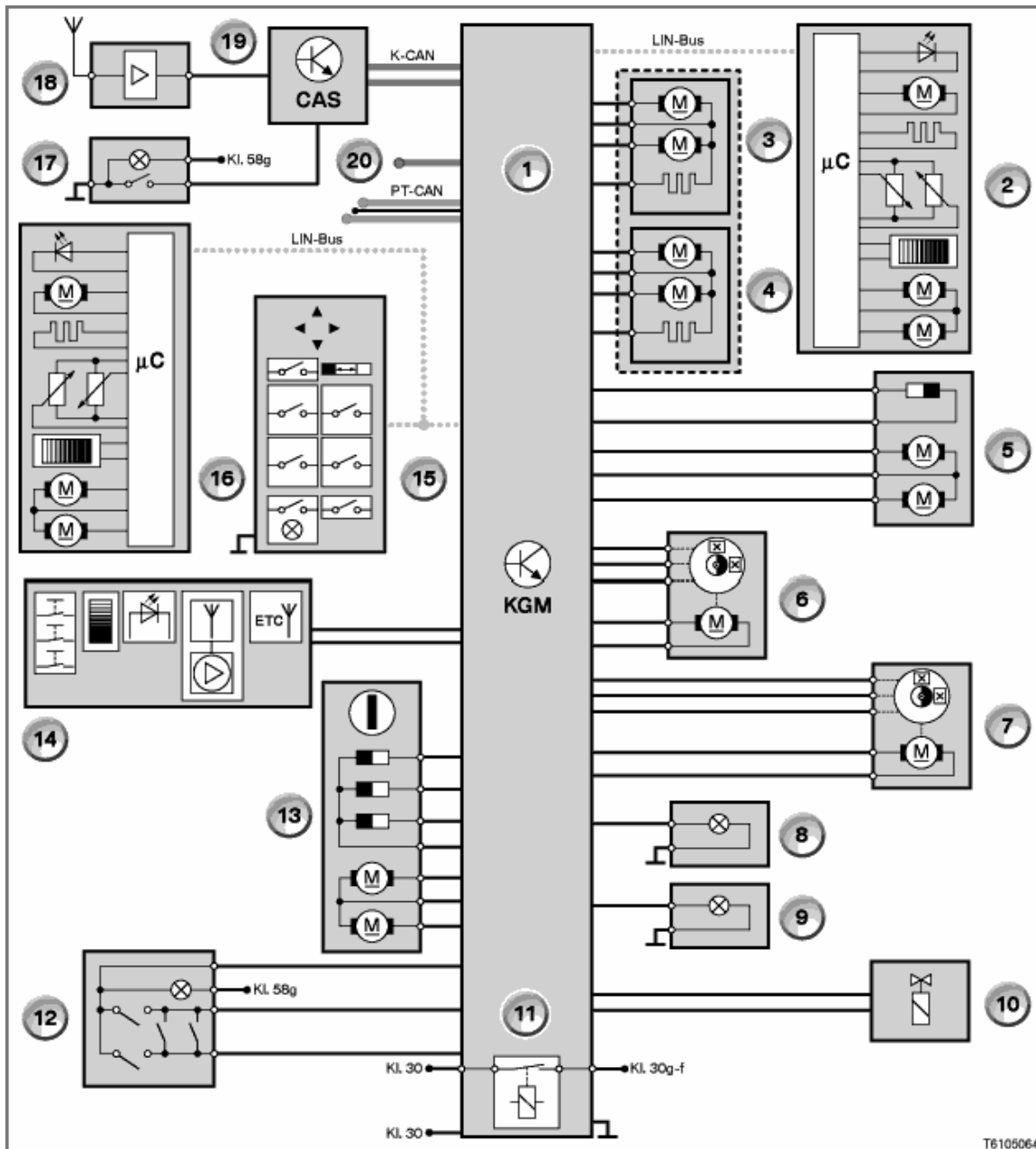

Item	Description	Item	Description
1	Body-gateway module (KGM)	2	Outside mirror with extended functions (passenger's side)
3	Basic outside mirror (driver's side)	4	Basic outside mirror (passenger's side)
5	Central-locking drive and door contact in the front passenger door	6	Power window motor with 2 Hall sensors in driver's door
7	Power window motor with 2 Hall sensors in passenger's door	8	Door entry light in driver's door
9	Door entry light in passenger's door	10	Servotronic valve
11	Bistable relay	12	Power-window switch in the front passenger door
13	Central-locking drive, lock cylinder and door contact in the driver's door	14	Electrochromic rear-view mirror
15	Switch block in the driver's door	16	Outside mirror with extended functions (driver's side)
17	Central locking button	18	Remote control receiver
19	Car Access System (CAS)	20	Diagnostic wire
Kl. 30	Terminal 30 (power supply)	Kl. 30g-f	Terminal 30 g-f (shut-down for closed-circuit current violation)
Kl. 58g	Terminal 58g (locator lighting)		
K-CAN	Body CAN	LIN-bus	Local data bus (Local Interconnect Network Bus)
PT CAN	Powertrain CAN		