Table of Contents

Voltage Supply and Bus Systems

Subject	Page
Voltage Supply and Bus Systems	5
Voltage Supply	5
System Components	7
Ground Points	7
Battery	8
Battery Service Information	8
Battery Cable	8
Intelligent Battery Sensor (IBS)	9
Micro-Power Module (MPM)	9
Rear Power Distributor with Terminal 30g Relay	9
Terminal 30g Relay (KL30g)	9
Front Power Distribution	10
Ignition Starter Switch	10
CAS	10
Digital Engine Electronics (DME)	10
Starter Relay	10
Component Locations	11
Principle of Operation	14
System Functions	14
Electric Energy Management	14
Power Management	15
Battery Charge Balance	16
State of Health of the Battery	17
Variable Charging Voltage	17
Battery Temperature	17
Consumer Current	17
Idling Speed Increase	18
Load Peak Reduction	18
Consumer Shutoff	19
Convenience Consumers	19
Legally Prescribed Auxiliary Consumers	19
Auxiliary Consumers	19
System Related Run-on	19
Off-load Current Monitoring	19
Terminal 30g Relay	19

Subject	Page
Intelligent Battery Sensor	20
Mechanical Section	20
IBS Measuring Ranges	21
Electronic Evaluation Module	22
IBS Hardware	23
IBS Software	23
IBS Functions	23
IBS Charge Management	24
Closed-Circuit Monitoring	24
IBS Wake-up	25
Servicing the IBS	26
IBS Diagnosis	26
Voltage Measurement	26
Current Measurement	27
Terminal 15 Wake-up Signal Faults	27
SoC/SoH	27
State of Charge	27
State of Health	27
Terminal 30g Relay	28
30g Switch On Conditions	30
30g Switch Off Conditions	30
Micro-Power Module	31
Normal Mode	31
MPM Switch-on Conditions	32
Switch-off Conditions	32
Sleep Mode	33
Service Information for MPM	34
Alternator	35
Digital Motor Electronics	35
Variable Battery Charging Voltage	36
Idle Speed Boost	36
Reducing Peak Loads	36
Electric Load Cutout	36
Battery Charge Management	37
Battery - State of Health	37
Data Transfer to the IBS	37
Closed-Circuit Current Diagnosis	37
Terminal 30g Relay	37

Subject	Page
Bus Systems	38
K-CAN	38
K-CAN Changes	38
MOST	39
Most Changes	39
byteflight	39
byteflight Changes	39
PT-CAN	39
Bus System Parameters	39
Sub-Bus Systems	40
LIN-Bus	40
LIN-Bus Main Controller	40
F-CAN	41
BSD (Bit-Serial Data Interface)	41
Sub-Bus System Parameters	42
MOST Connector Junction	42
Bus System Overview (E61)	43
Bus Systems (E63 and E64)	44

Voltage Supply and Bus Systems

Model: E60, E61, E63 and E64

Production: All

OBJECTIVES

After completion of this module you will be able to:

- Understand IBS Operation
- Explain Power management
- Recognize bus systems on E60,E61, E63 and E64
- Diagnose voltage supply faults

Voltage Supply and Bus Systems

Voltage Supply

The voltage supply on the BMW 5 and 6-Series is similar to that on the E65. However, the 5 and 6-Series do not have the power module from the E65. A network of hardware and software assumes the role of energy management. The energy management system monitors and controls the vehicle's energy requirements, both when driving as well as when stationary.

The energy management system comprises the functions of the electric energy management system and the power management functions contained therein.

The "State of Charge" (SoC) and the "State of Health" (SoH) of the battery are determined continuously with the power management system.

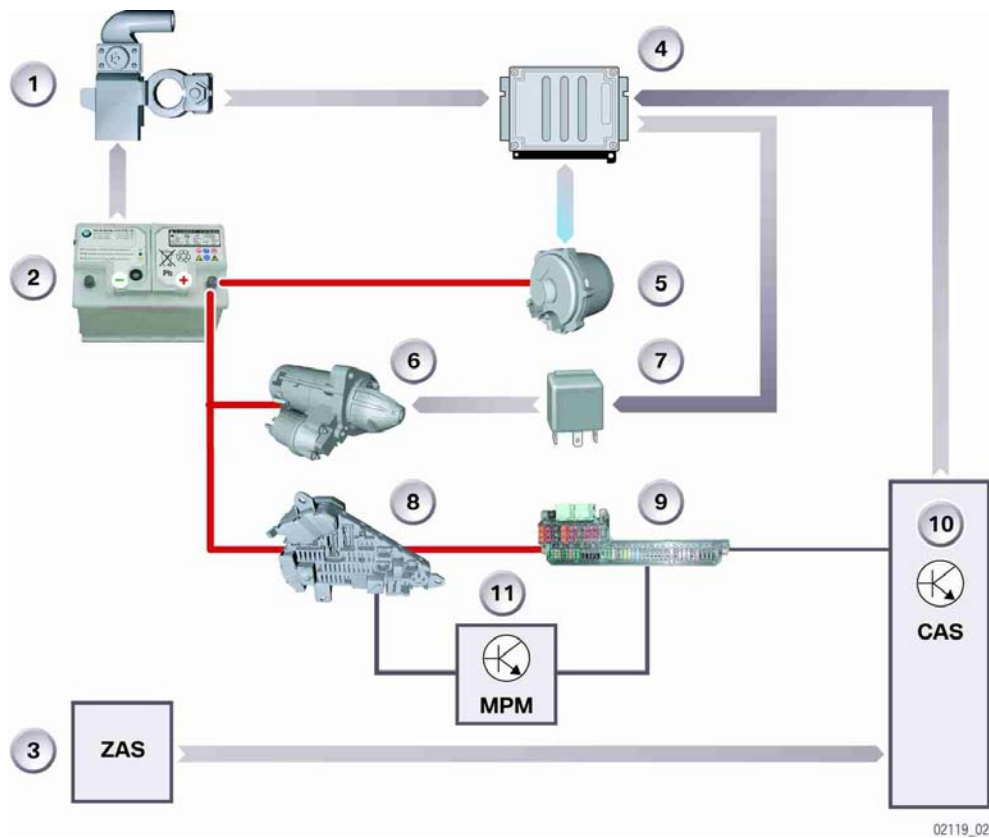

Index	Explanation	Index	Explanation
1	Intelligent Battery Sensor (IBS)	7	Starter relay
2	Battery	8	Rear power distribution box w/ KL30g relay
3	Ignition/Starter switch	9	Front power distribution box
4	DME (ECM)	10	Car Access System (CAS)
5	Alternator	11	Micro-Power Module (MPM)
6	Battery		

The most important components and functions of the electric energy management system are:

- The intelligent battery sensor (IBS) for continuous measurement of the battery values.
- The software of the power management system in the Digital Motor Electronics (DME) and in the IBS.
- The terminal 30g relay, which is actuated by the Car Access System (CAS).
- The micro-power module (MPM), which is located between the front and rear power distributors.

New features of the power supply are:

- IBS
- Terminal 30g relay (terminal 30 active)
- MPM
- Ground point on "reduced-weight aluminum front end" (GRAV)

Advantages of the power supply are:

- Precise identification of the "State of Charge" (SoC) and "State of Health" (SoH) of the battery by the power management system.
- IBS designed for use with different assembly groups.
- Reduced off-load current: The consumers on terminal 30g are switched off in a defined manner by the terminal 30g relay.
- A defined connection between the aluminum front end and the steel bodywork with the GRAV ground point in the engine compartment.
- The GRAV ground point improves the vehicle's electromagnetic compatibility (EMC).
- More headroom in the rear of the vehicle. The routing of the battery cables in the outer area allows the seats and carpets in the rear of the vehicle to be installed with reduced height.

System Components

The power supply system consists of the following components:

- Vehicle Ground Points
- Battery
- Battery Cable
- Intelligent Battery Sensor with ground Lead (IBS)
- Terminal 30g Relay
- Micro-Power Module (MPM)
- DME
- Car Access System (CAS)

Ground Points

The ground point (GRAV) improves the electromagnetic compatibility (EMC) of the vehicle. Aging connections between the front end and the remaining car body do not affect the EMC. The contact resistances between the front end and the remaining car body are bridged by means of the ground lead.

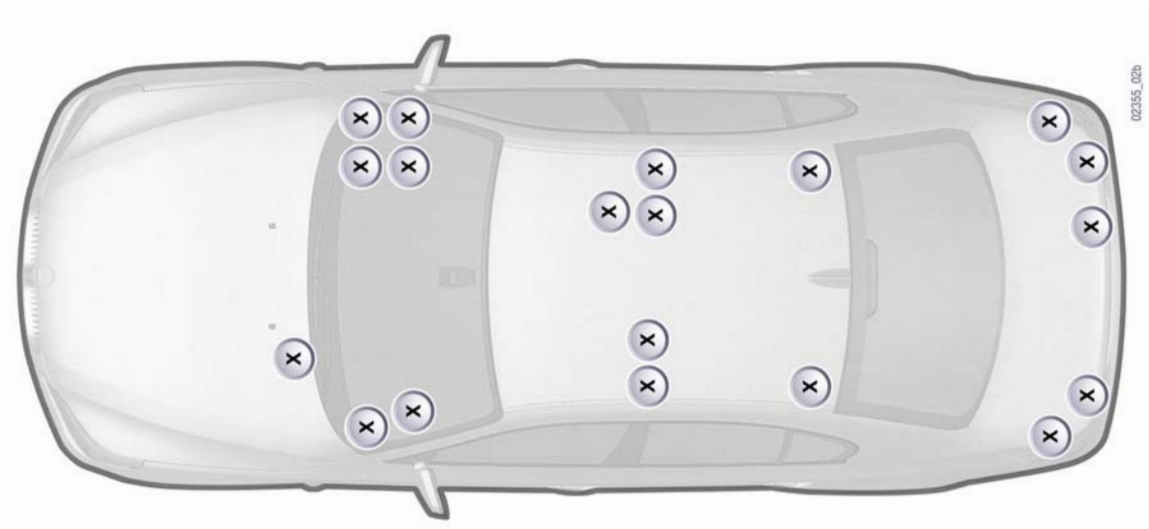
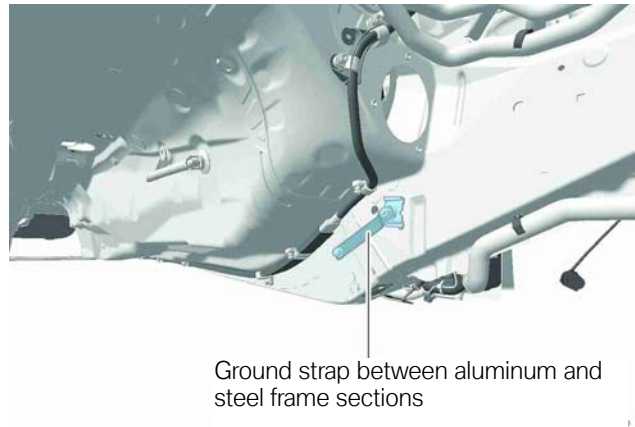

Battery

The battery size depends on the engine and equipment configuration.

Battery Service Information

The battery size is coded in the DME. Replacement batteries must be the same capacity rating as the original battery.

Particular attention must be paid to the cables and the IBS when replacing a battery. Irreparable damage may occur if the cables and IBS are subjected to high mechanical stress and strain. Refer to service information for the IBS.

As on the E65, the power management system is to be initialized by means of the diagnosis job "Control_battery_replacement_register." Follow the repair instructions.

Battery Cable

The battery cable is installed on the underside of the vehicle. The battery cable is monitored by the ASE system as in the E85. Sensor leads are routed from the battery cable to the left and right B Pillar satellites.

Battery cable size is dependent on engine. Most US vehicles use 120mm² aluminum Ribbon cable.

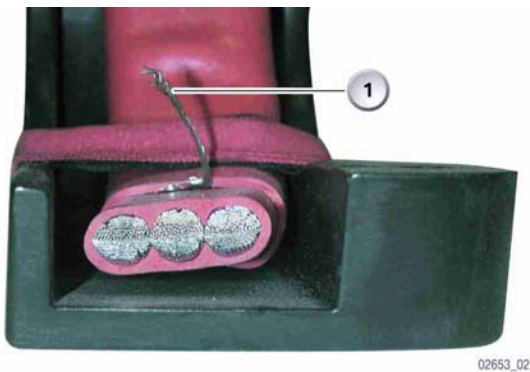

Cross Section of battery cable with sensor lead

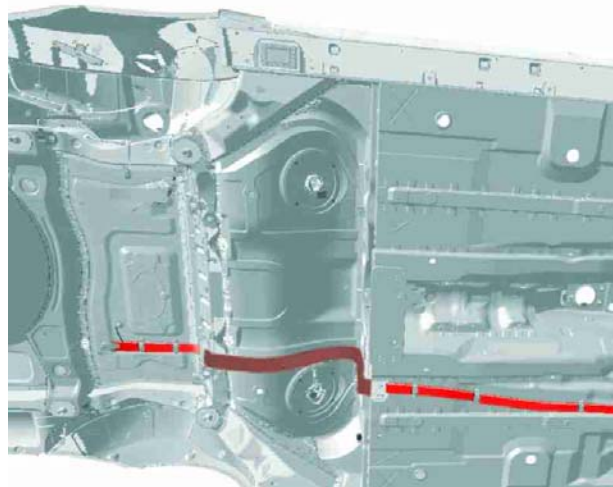

Undercar routing of battery cable

Intelligent Battery Sensor (IBS)

The IBS is a mechatronic, intelligent battery sensor with its own microcontroller. The IBS continuously takes measurements at the battery which include:

- Terminal voltage
- Charge current
- Discharge current
- Battery (electrolyte) temperature

Micro-Power Module (MPM)

When the vehicle is at rest, the MPM switches individual consumers off, if:

- The off-load current is too high when the critical "State of Charge" (SoC) is reached
- Undervoltage occurs
- Too many "wake-up" circuits are activated in the K-CAN
- The vehicle fails to go into sleep mode

The micro-power module (MPM) is connected to the K-CAN and located in the luggage compartment.

Rear Power Distributor with Terminal 30g Relay

The rear power distributor is installed in the luggage compartment . (refer to ETM for specific location). The rear power distribution box is connected to the positive terminal of the battery, the front power distribution box and the external-start support point. The MPM is connected to the rear power distribution box (and the front power distribution).

Terminal 30g Relay (KL30g)

The terminal 30g relay is actuated by the Car Access System (CAS) and prevents increased off-load current by switching off individual consumers.

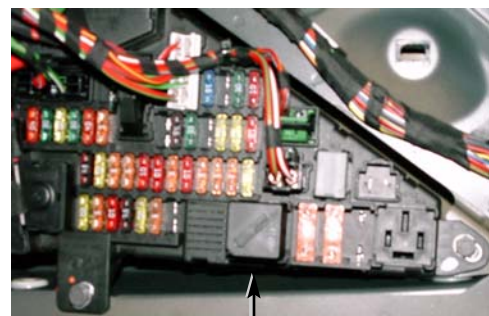

KL30g Relay

Front Power Distribution

The front power distribution box (fusebox) is connected to the rear power distributor. The CAS and the starter motor are connected to the front power distributor.

Ignition Starter Switch

The ignition starter switch is located on the right-hand side of the steering column. The ignition starter switch is directly connected to the Car Access System (CAS).

CAS

The CAS comprises the functions:

- Terminal control
- Electronic immobilizer (EWS)
- Evaluation of radio signals from remote control

The CAS is directly connected to ignition starter switch by cables. The DME (ECM) and the starter motor are connected to the CAS. The CAS is part of the K-CAN bus network.

Digital Engine Electronics (DME)

The digital engine electronics system (DME) is responsible for engine management. The ECM includes the electronic immobilizer (EWS) and is also used for redundant (2-fold) data storage. The ECM is connected to the Powertrain CAN (PT-CAN) data bus to allow it to communicate with other control units in the vehicle.

Starter Relay

The starter relay switches the battery voltage to the starter motor, when:

- The ignition starter switch is in switch position 2,
- The CAS receives the correct information and transmits this to the DME / DDE via the K-CAN,
- The electronic immobilizer (EWS) actuates the starter relay.

Front Power Distribution Box

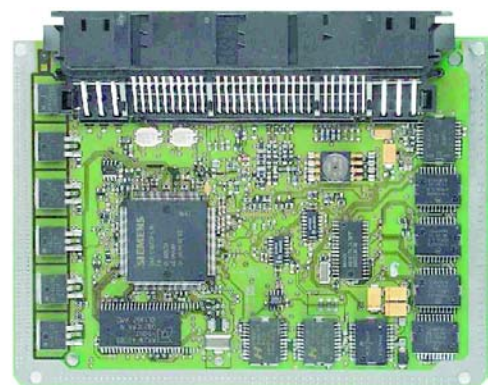

Component Locations

E60

Rear Power Distribution Box

- 1. KL30g relay
- 2. Heated rear window relay

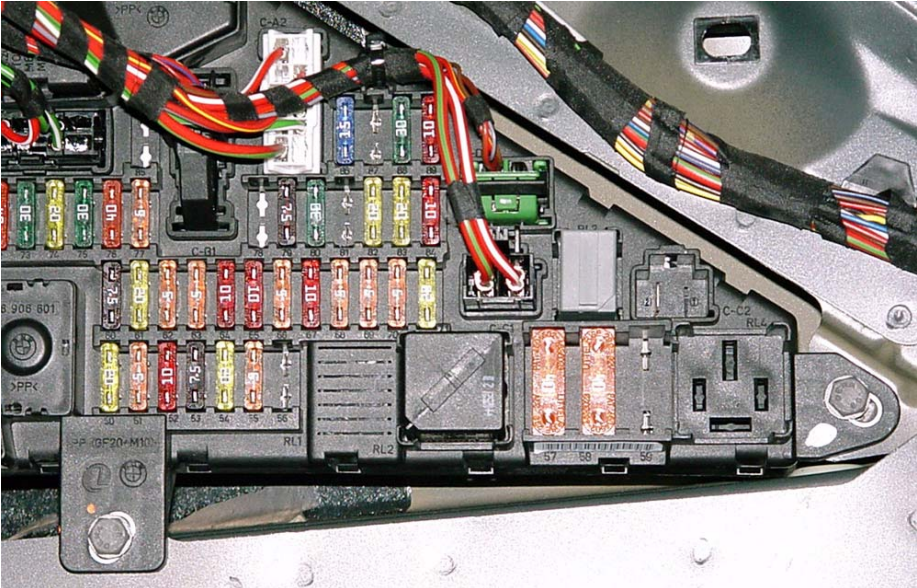
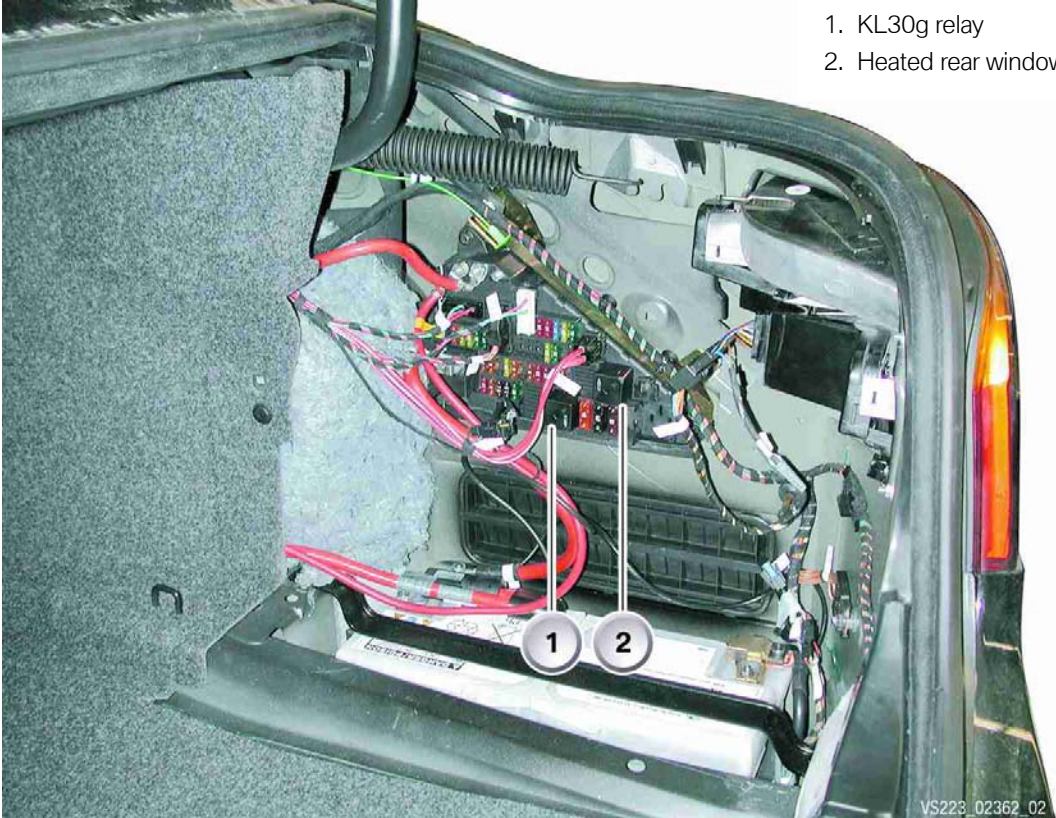

Rear Power Distribution Box

E63/E64

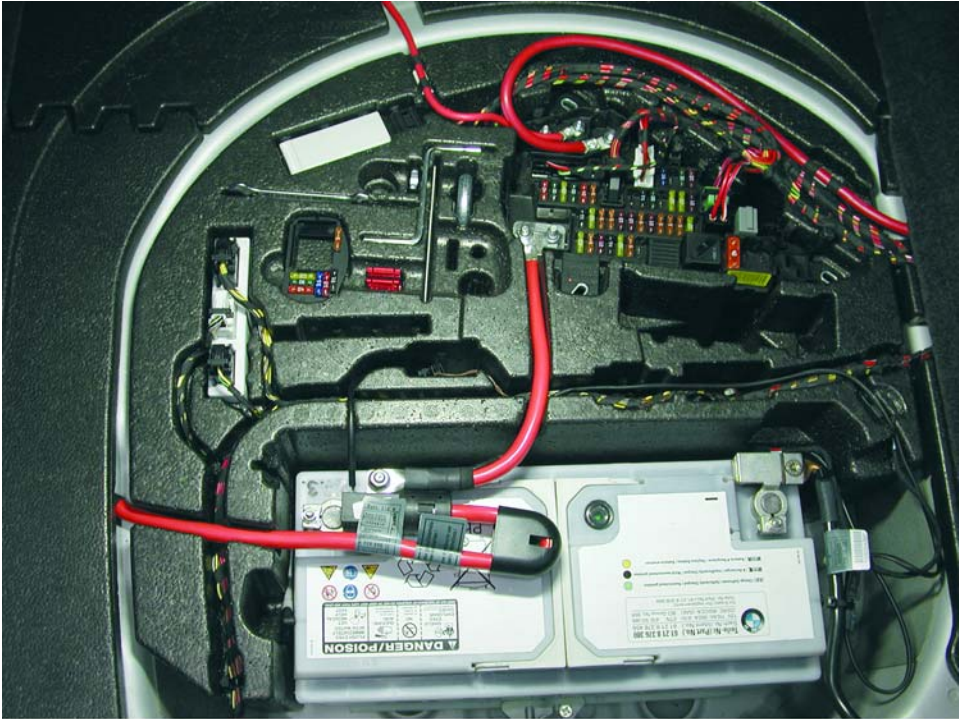

03642_03

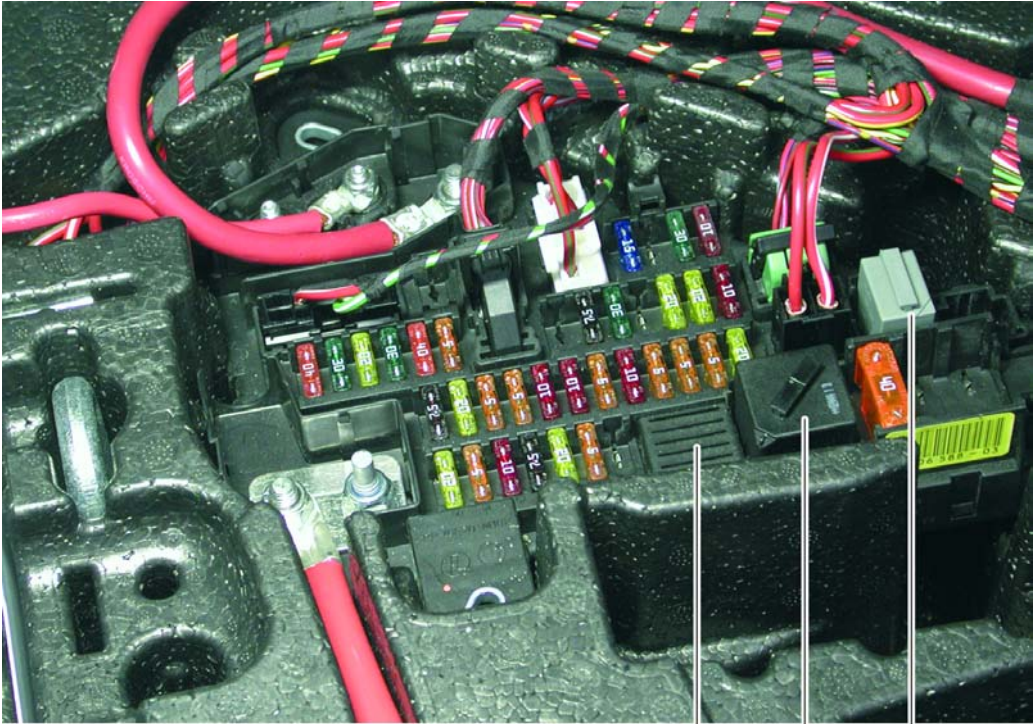

03643_03

- 1. Rear window relay
- 2. Terminal 30g relay
- 3. Terminal 15 relay (soldered)



E61

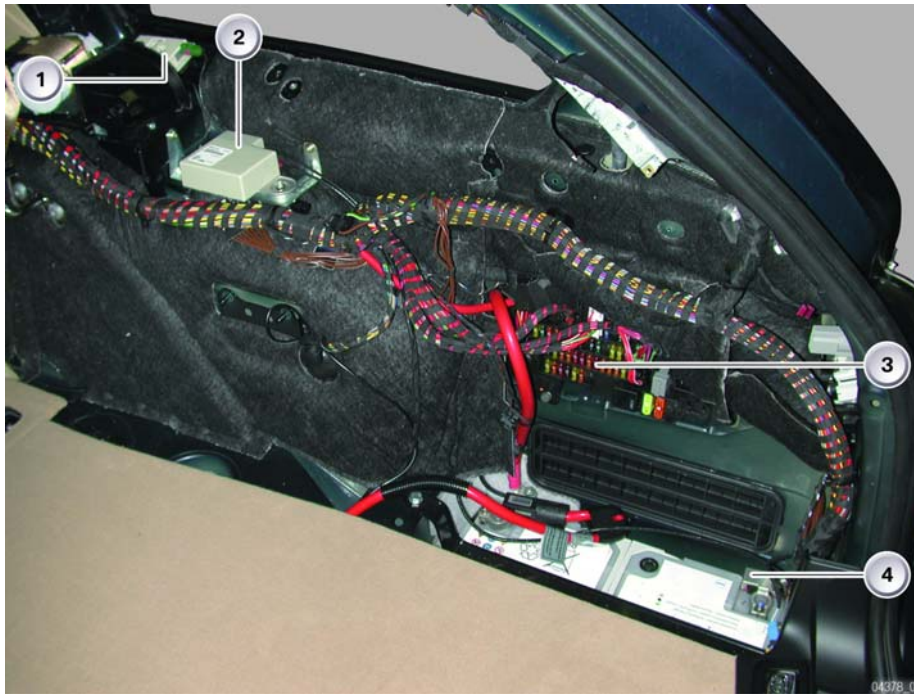

- | | |
|---|-------------------------------------|
| 1. TV Antenna Amplifier, right (not for US) | 3. Rear power distribution box |
| 2. Telephone emergency call antenna | 4. Intelligent battery sensor (IBS) |

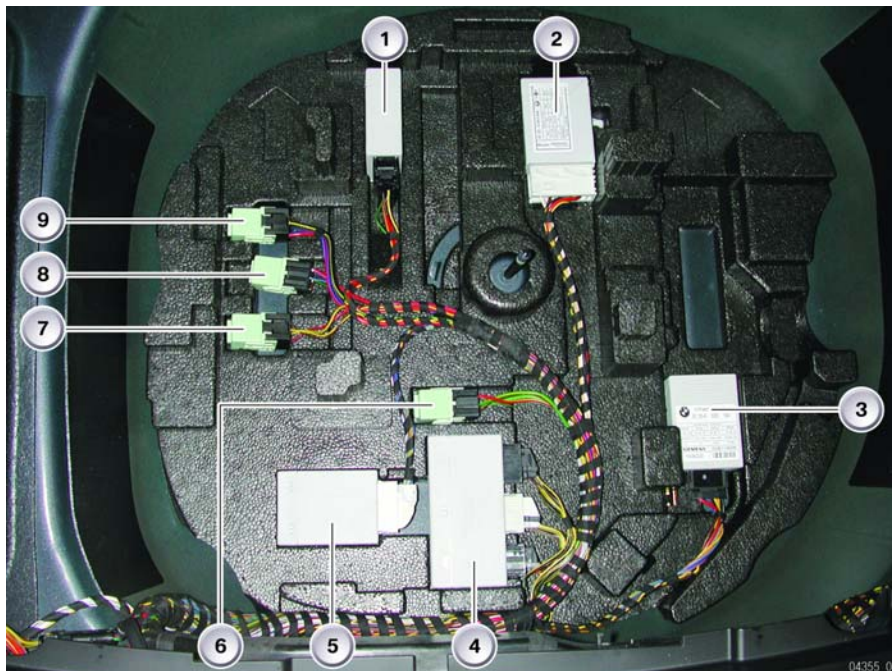

- | | |
|---|---------------------------------|
| 1. Micro-power module (MPM) | 6. Load -shedding relay for EDC |
| 2. Rear Hatch Lift Module (HKL) | 7. Relay, rear window wiper |
| 3. Trailer module (AHM) (not for US) | 8. Relay, automatic soft close |
| 4. Park distance control (PDC) | 9. Relay, compressor for EHC |
| 5. Electronic ride height control (EHC) | |

Principle of Operation

System Functions

The power supply system comprises the following functions:

- Electric energy management
- Power management
- Variable charge voltage
- Idle-speed increase
- Reduction of load peaks
- Consumer shutdown
- Off-load current monitoring
- Terminal 30g relay

Electric Energy Management

The electric energy management monitors and controls the vehicle's energy requirements. The monitoring and control functions are performed by the interconnection of various components. The energy management links functions, signals and maps for generating and outputting control signals.

Components of the energy management system:

- Battery
- IBS
- Bit-serial data interface (BSD)
- DME or DDE
- Engine
- Power management (microcontroller)
- Micro-power module (MPM)
- Alternator
- Terminal 30g relay
- Consumers on terminal 30/terminal 30g

Function/systems involved in energy management:

- Power management
- Car Access System (CAS)

Signals/maps in energy management system:

- Current flow to consumers
- Increased idling speed
- Battery charge current
- Nominal value for charge voltage
- Consumer reduction
- Terminal 15 wake-up wire

Power Management

The power management is on the one hand part of the electrical energy management system. Power management is software stored in the DME and in the intelligent battery sensor that is used for controlling the vehicle's energy requirements.

Power management comprises the functions controlled by the software in the DME and in the IBS:

- Variable charge voltage for the battery by adapting the charge voltage from the alternator to that required by the battery.
- Increased idling speed to boost the alternator's output .
- Reduction of load peaks through power reduction when the vehicle's electrical system is unable to provide the energy needed (vehicle electrical system deficiency).
- Auxiliary consumers switched off via CAN messages when engine has reached its limit of starting capability.
- Off-load current monitoring.

Power management links the input signals with the characteristic curves stored in an EPROM (Erasable Programmable Read-Only Memory) and generates the output signals to control energy requirements.

Power management components:

- DME or DDE
- EPROM
- Microcontroller (C)

Power management input signals:

- Battery voltage (U)
- Current ($I \pm$)
- Temperature (T)

Maps

- Battery voltage (U)
- Current ($I \pm$)
- Temperature (T)

Output signals

- Idle-speed control
- Nominal value for charging voltage
- Auxiliary consumer shutdown
- Load peak reduction

The power management system measures the "State of Charge" (SoC) and the "State of Health" (SoH) of the battery.

Battery Charge Balance

The charge balance of the battery is determined by the charge quantity flowing into and out of the battery. Two counters are provided in the power management to give a running balance of the battery's charge state. One of the counters counts the charge quantity taken up by the battery. Another counter counts the charge quantity discharged from the battery. At the factory, the counters are calibrated for the battery fitted. The IBS transmits the data to power management in the DME / DDE. The data are transmitted via the bit-serial data interface (BSD).

The difference between the two charge quantities is the battery's state of charge (SoC). After the engine has been shut down, the power management will calculate the current SoC value when the engine is restarted.

State of Health of the Battery

The battery's state of health is derived from the drop in battery voltage during the starting procedure and from the starting current. These data are measured by the IBS during the starting procedure. The average value of the starting current in the start phase and the value of the voltage dip are transmitted to the DME / DDE via the bit-serial data interface (BSD). The starting procedure is indicated to the IBS by currents greater than 200 ampères (A). The "engine running" signal is output by the DME / DDE as soon as the engine starts.

The power management system calculates the battery's internal resistance from the average value of the starting current and the value of the voltage dip. The internal resistance of the battery gives a good indication of the battery's State of Health (SoH).

Variable Charging Voltage

The variable charging voltage for the battery ensures that an optimal battery charge state is maintained, even in unfavorable driving situations. unfavorable driving situations are, e.g. city traffic and driving in congested traffic.

The charging voltage varies, depending on

- Battery temperature and
- Consumer current.

Battery Temperature

The temperature-dependent adjustment of the battery charging voltage prevents an undesirable increase of the battery temperature during recharging.

Moreover, the battery temperature remains lower, even at higher ambient temperatures. This reduces the amount of gas generated during charging and the amount of distilled water consumed.

Consumer Current

The level of consumer current is measured by the IBS and transmitted to the power management via the bit-serial data interface (BSD). From this, the power management derives the charging voltage level to be generated by the alternator. This charging voltage nominal value, as derived by the power management, determines the level of the charging voltage generated by the alternator. This determines the battery charge current, which in turn influences the battery charging process, and ultimately the vehicle's consumer current.

Idling Speed Increase

The idling speed of the engine is raised by the DME to 750 rpm if the specified battery charging voltage level is not achieved.

The idling speed is raised when:

- The alternator is at full capacity **and**
- The battery's state of charge is too low.

Load Peak Reduction

If the charge state of the battery does not improve, even after the idling speed has been increased, the peak load in the vehicle electrical system is reduced. The peak load reduction is achieved by the following actions:

- Pulsing the load with pulse width modulation (PWM) signals

In this process, consumers are switched on and off for defined times.

- Power draw is reduced to a certain percentage.
- Individual consumers are switched off in extreme situations when the power reduction achieved through pulsing and reduced consumption is insufficient.

The load on the vehicle electrical system is reduced according to the table:

Priority of consumers	Power reduction	Control unit
Heated rear window	Pulsing	IHKA
Seat heating	Level 2	SM
Seat heating	50 %	SM
Active seat	Off	SM
Heater blower	75 %	IHKA
Steering wheel heating	Pulsing	SZL
Heater blower	50 %	IHKA
Mirror heating	Off	TM
Heated rear window	Off	IHKA
Seat heating	Off	SM
Steering wheel heating	Off	SZL
Seat climate	Off	SM
Heater blower	25 %	IHKA

Consumer Shutoff

Consumers are switched off according to different criteria and are split into the following categories:

Convenience Consumers

- Window heating
- Seat heating
- Steering wheel heating

The convenience consumers are automatically switched off when the engine is switched off. The convenience consumers can only be switched on again after the engine has been restarted.

Legally Prescribed Auxiliary Consumers

- Side lights
- Hazard warning lights

Legally prescribed auxiliary consumers must still be operational when the engine has been switched off, as long as this is possible. These auxiliary consumers are not switched off, even if the battery's limit of starting capability has been reached.

Auxiliary Consumers

- Independent heating
- Independent ventilation
- Communications components (Displays - Terminal 30g and Telematic services)

The auxiliary consumers listed can still be switched on after the engine has been switched off. The auxiliary consumers are automatically switched off when the battery reaches its limit of starting capability. A CAN message from the DME / DDE prompts the shutdown.

System Related Run-on

- Electric radiator fan

System-related run-on components can remain operational for a certain time after the engine has been switched off.

Off-load Current Monitoring

If the battery current exceeds 80 milliamperes (mA) in off-load state (setting programmed at factory), a fault entry will be stored in the DME / DDE.

Terminal 30g Relay

The terminal 30g relay prevents a higher off-load current, e.g. one caused by a defective consumer, with a predefined consumer shutoff. The terminal 30g relay is actuated by the CAS. The "g" indicates that terminal 30g is an active terminal.

Intelligent Battery Sensor

The IBS is a mechatronic intelligent battery sensor with its own microcontroller. It constantly measures the following:

- Battery terminal voltage
- Battery charge/discharge current
- Battery acid temperature

Installed directly at the negative battery terminal, care should be used when removing and installing the negative battery cable.

The IBS consists of 3 functional elements:

- Mechanical section
- Hardware
- Software

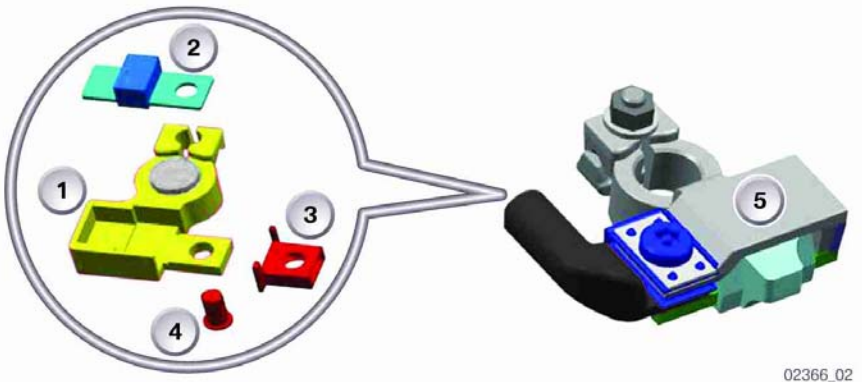

Index	Explanation	Index	Explanation
1	Pole Terminal	4	Screw
2	Shunt	5	IBS
3	Spacer		

Mechanical Section

The mechanical part of the IBS consists of the battery terminal for the negative pole with ground cable. Tasks of the mechanical section of the IBS:

- Providing electrical contact of the car body with the negative pole of the battery
- To accommodate the sensor element for current measurement
- To provide mounting for the hardware
- Providing sufficient thermal contact between the temperature sensor of the hardware and the negative pole of the battery
- Providing protection for the sensitive electronic components
- The battery terminal provides the ground connection for IBS

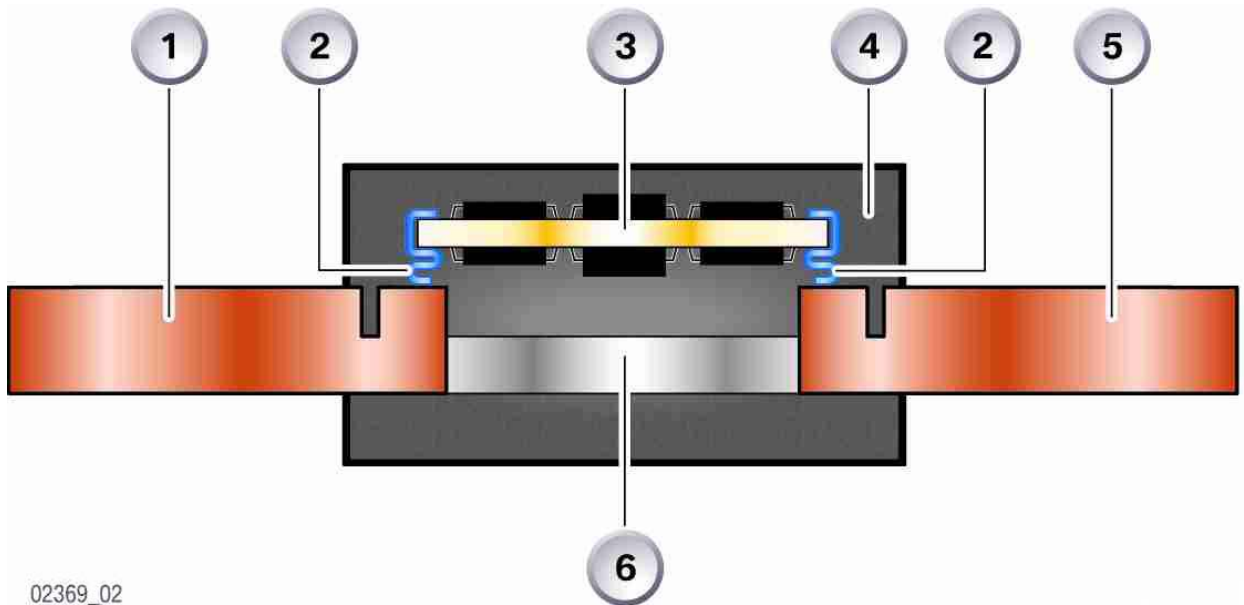

02369_02

Index	Explanation	Index	Explanation
1	Copper	4	Injection molding
2	Gullwings (tabs)	5	Copper
3	PC board with evaluation electronics	6	Manganin

Manganin

A copper alloy resistor of low resistance value, that maintains an extremely constant temperature, regardless of current flow. Used as a shunt resistor to measure current flow by the evaluation electronics of the IBS

IBS Measuring Ranges

- Voltage 6 V to 16.5 V
- Current -200 A to +200 A
- Closed circuit current 0 A to 10 A
- Starting current 0 A to 1000 A
- Temperature -40°C to 105°C

Electronic Evaluation Module

The electronic evaluation module of the IBS continuously registers the measured data. The IBS uses these data to calculate the following battery indicators.

- Voltage
- Current
- Temperature

The IBS sends the calculated battery indicators to the DME via the BSD. The IBS calculates changes in battery SoC/SoH based on information received from the DME on the SoC of the battery during the period of time between engine "OFF" and deactivation of the DME relay. After the DME relay has been switched off, the IBS continues to constantly observe the SoC of the battery.

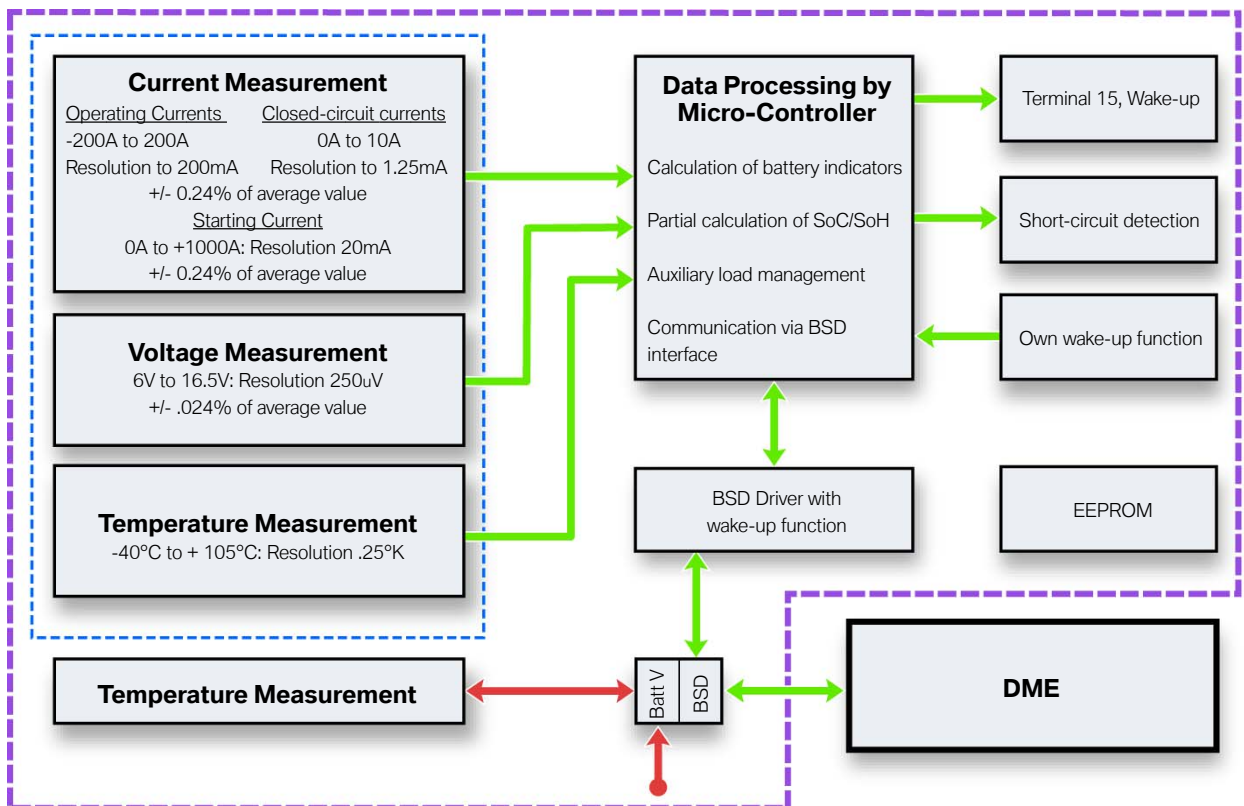

02915_02

IBS Hardware

IBS Hardware consists of the following:

- Shunt for current measurement
- Temperature Sensor
- Multi-layer pc-board as the electronic circuit including the electronic components.

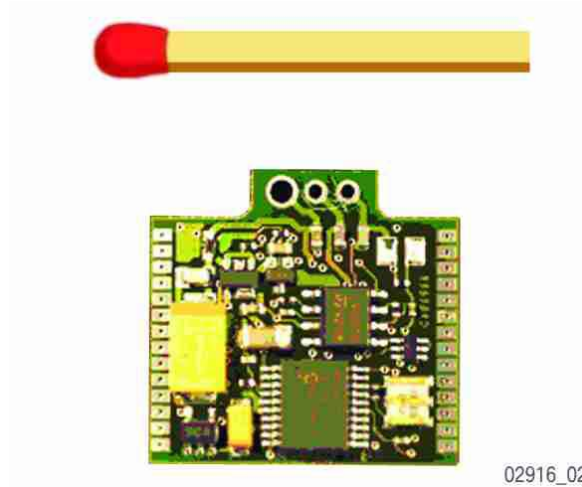

IBS Software

The software in the PC-board of the IBS calculates State of Charge and State of Health of the battery and sends the information to the DME. Communication with the DME, which takes place via the BSD, allows the DME to obtain data constantly from the IBS during vehicle operation.

IBS Functions

The following functions are integrated in the IBS:

- Continuous measurement of current, voltage and temperature of the battery under all vehicle operating conditions
- Calculation of battery indicators as basis for SoC and SoH
- Monitoring of battery charge/discharge current
- Monitoring of SoC and notification to DME of critical SoC
- Partial calculation of SoH Based on starter draw
- Closed-circuit current monitoring in vehicle
- Data transfer to DME
- Self-diagnosis
- Self wake-up capability during sleep mode

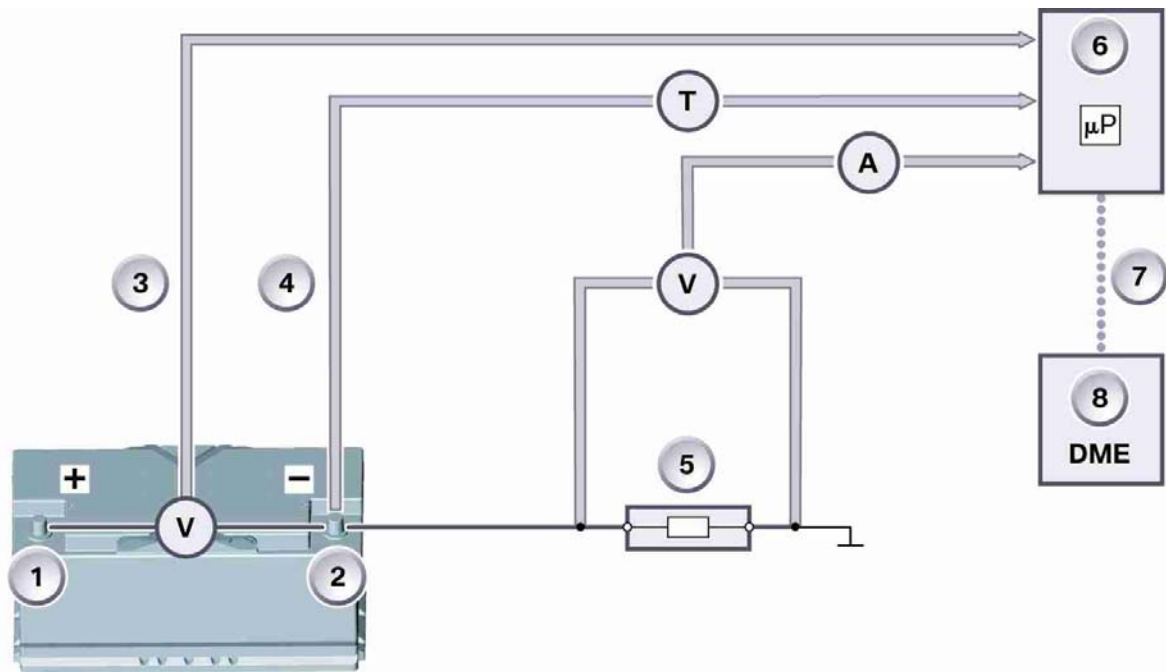

02382_02

Index	Explanation	Index	Explanation
1	Battery positive	5	Current measurement
2	Battery negative	6	Microcontroller (in IBS housing)
3	Battery voltage measurement	7	BSD (Bit Serial Data line)
4	Temperature measurement	8	DME (ECM)

IBS Charge Management

The IBS continuously manages the charge status of the battery when the key is off. The current SoC is stored in the IBS every 2 hours.

When the IBS receives the terminal 15 “wake up signal” the DME is updated with the current values of the battery indicators.

Closed-Circuit Monitoring

When the vehicle is off the IBS is programmed to wake up every 40 seconds so that it can update the measured values (Voltage, current, temperature). The measuring time of the IBS is approximately 50 ms.

The DME reads the history of the measurements on start-up. An entry is made in the fault code memory of the DME if a closed-circuit current draw was present.

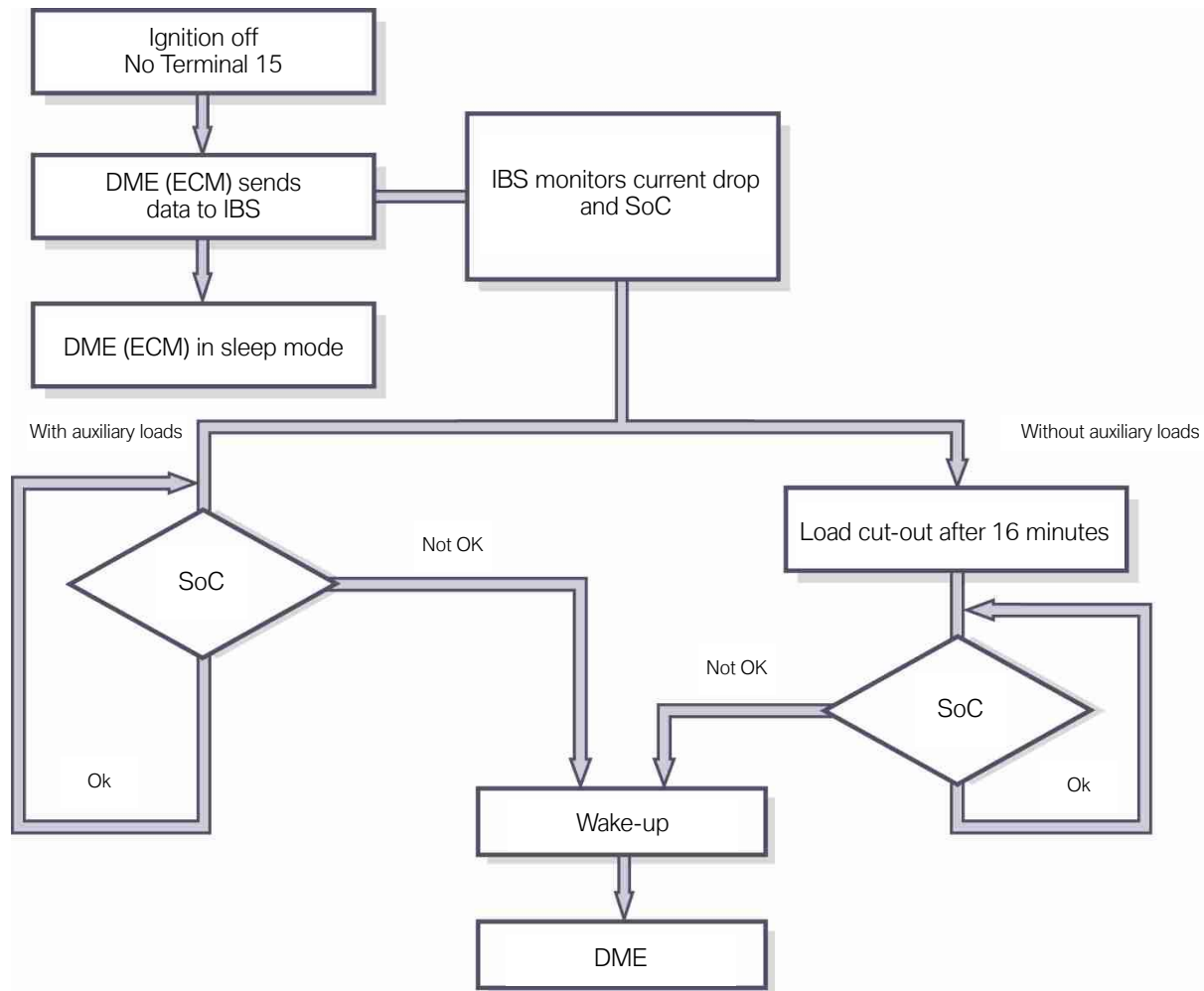

VS223_02372_02

IBS Wake-up

When the key is switched off, before the DME enters sleep mode, the DME informs the IBS of the current SoC of the battery. The IBS monitors the SoC and when it drops below the programmed threshold, a wake-up signal is sent to the DME via the BSD. The DME wakes up, obtains information on the current SoC of the battery from the IBS and requests the auxiliary electrical loads to switch off.

After one wake-up sequence the IBS is prohibited from waking the vehicle again during this key off cycle. The vehicle subsequently reassumes sleep mode.

Servicing the IBS

The IBS is very sensitive to mechanical stress and strain. It is serviced as a complete unit with the ground cable. The ground cable also serves as a heat dissipater for the IBS.

Particular attention should be paid to the following points in service:

- Do not make any additional connections at the negative terminal of the battery
- Do not modify the ground cable
- Do not make any connections between the IBS and the sensor screw
- Do not use force when disconnecting the ground terminal from the battery
- Do not pull at the ground cable
- Do not use the IBS as a pivot point to lever off the ground terminal
- Do not use the connections of the IBS as a lever
- Use only a torque wrench as described in the repair manual
- Do not release or tighten the sensor screw

A fault code is stored in the DME when the IBS is defective. The DME adopts a substitute value and assumes IBS emergency mode. IBS emergency mode boosts the idle speed in order to sufficiently charge the battery.

Note: The software in the DME and that of the IBS must match. To ensure this requirement it may be necessary to replace the IBS in connection with a software update.

IBS Diagnosis

The IBS features a fault code memory that is read out by the DME. Self diagnosis checks the voltage, current, temperature measurement, terminal 15 wake up as well as system errors in the IBS.

Direct diagnosis of the IBS is not possible, it must be diagnosed through the DME.

Voltage Measurement

If the IBS is shorted to ground, a DME fault code will display “Voltage Fault DME ON”. The IBS will be unable to wake up the DME.

If the IBS is shorted to B+, a DME fault code will display “Voltage fault, DME not ON” and no charging current. The vehicle will NOT enter sleep mode.

Current Measurement

Current measurement is a very dynamic process, indicated by the measuring range of mA to kA.

The fault code “Current Fault” is entered in fault memory when an implausible value is determined during the plausibility check of the various measuring ranges of the IBS.

Terminal 15 Wake-up Signal Faults

The IBS recognizes wake-up line faults. The IBS can detect a wake-up line error under the following conditions:

- DME “ON”
- Terminal 15 “ON” (voltage high at IBS)
- Terminal 15 running via BSD

If Terminal 15 at the IBS and Terminal 15 via the BSD are not equal, a fault is indicated in the BSD line or an IBS Fault.

The IBS fault may be caused by:

- Terminal 15 Driver in the IBS has a short to ground
- Terminal 15 Driver in the IBS has a short to B+ or is defective.

SoC/SoH

State of Charge

SoC is a calculated condition showing the current charge in the battery. The SoC calculations are performed by the DME. SoC is used during key off periods to insure the battery maintains a sufficient charge to start the engine at least one more time.

State of Health

SoH tracks the history of the battery in the vehicle. Charge/discharge cycles and times are monitored. SoH helps the DME determine the proper charging rates and anticipated battery life.

The IBS detects vehicle start based on current draw in excess of 200A. The engine running signal is made available by the DME via the BSD. Internal resistance of the battery is calculated from the current and voltage dip. These indicators are forwarded to the DME. From this data, the DME the state of health (SoH) of the battery.

Terminal 30g Relay

The Terminal 30g Relay prevents increased closed-circuit current consumption by switching off electric loads.

The switch-off procedure disconnects various electric loads in a defined manner from the vehicle electrical system. This happens approximately 60 minutes after terminal R "OFF." The deactivated electric loads are activated again together with terminal 30g "ON."

The terminal 30g relay is actuated by the car access system.

Power to the following control units is managed by the terminal 30g relay:

- Center console switch center (SZM)
- Rain and low beam sensor (RLS)
- Controller
- Central information display (CID)
- Slide/tilt sunroof (SHD/MDS)
- Satellite radio (SDARS)
- TOP HiFi amplifier
- Telephone
- Head-up display (HUD)
- Active cruise control (ACC)
- Electronic transmission control/SMG
- Dynamic stability control (DSC)
- Adaptive cornering light (AHL)

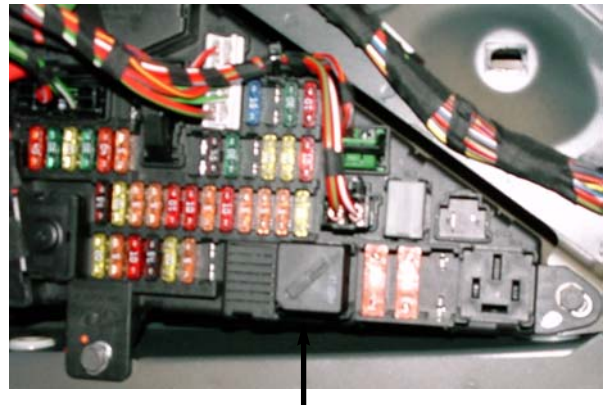

Terminal 30g relay location

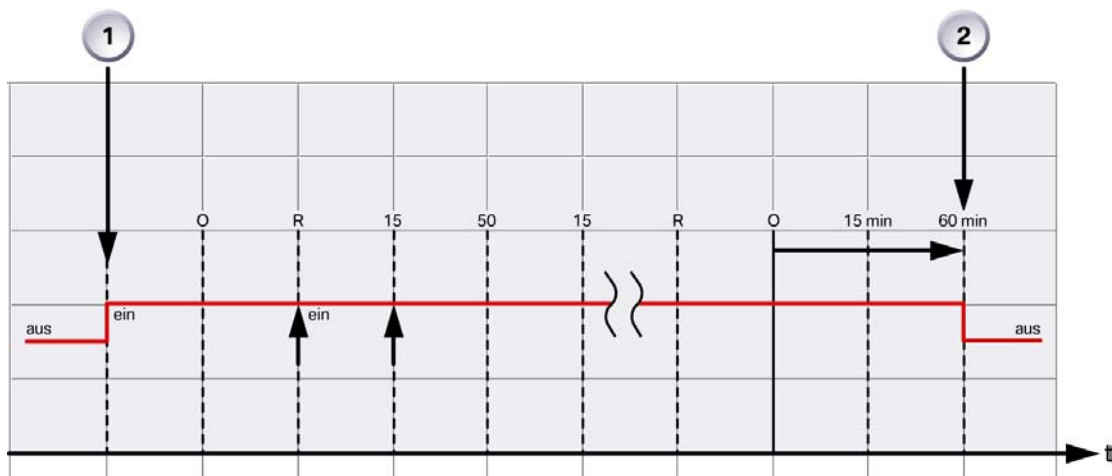

02072_02

30g and MPM System Schematic

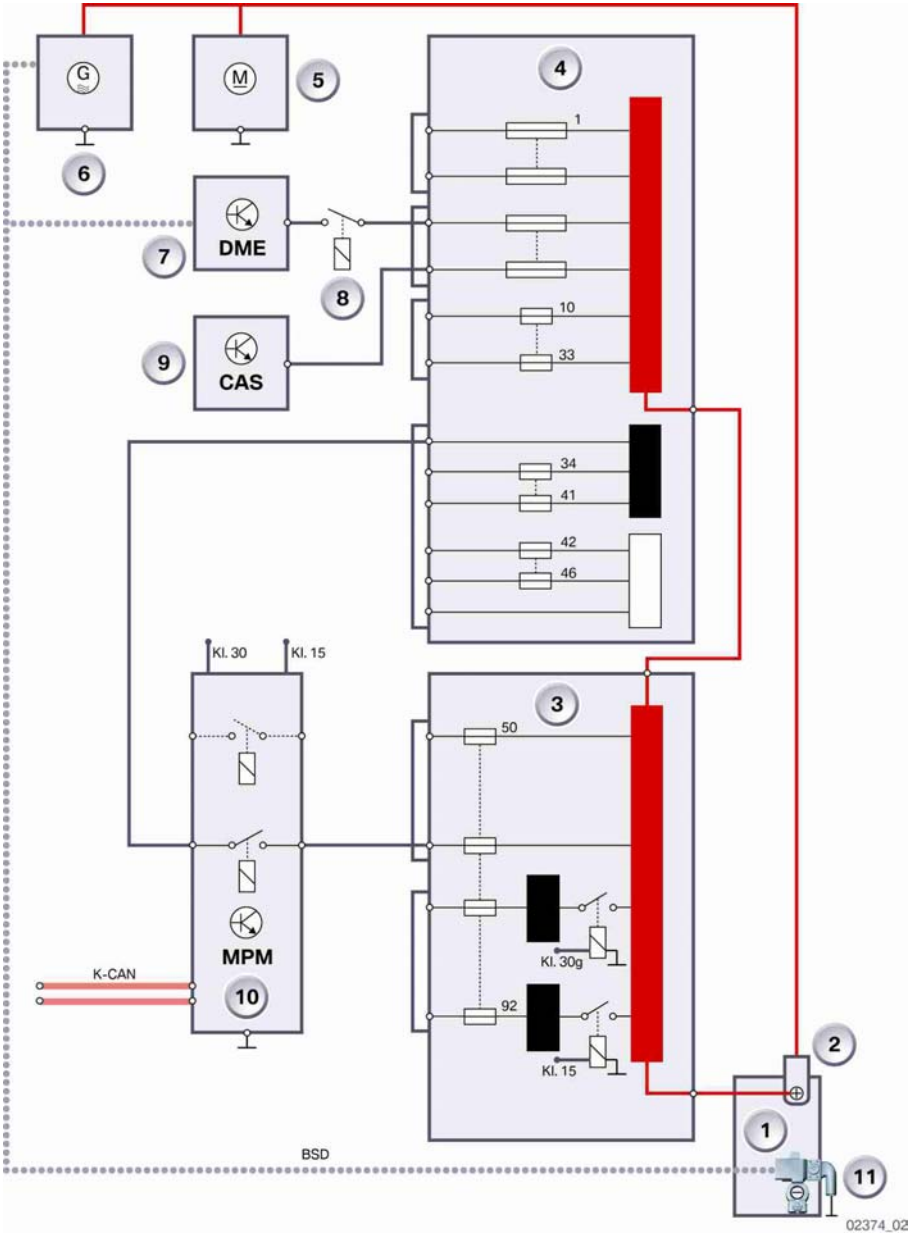

Index	Explanation	Index	Explanation
1	Battery	7	DME (ECM)
2	BST	8	DME (ECM) Relay
3	Rear power distribution w/KL30g and KL15 relays	9	CAS
4	Front power distribution box	10	MPM
5	Starter motor	11	IBS
6	Alternator		

30g Switch On Conditions

The switch-on conditions for terminal 30g relay are as follows:

- Unlock vehicle or
- Terminal R or
- Status change of door contacts or of trunk contact or
- Telephone wake-up line for telematic services or
- Service applications

30g Switch Off Conditions

The switch-off conditions for terminal 30g relay are as follows:

- 60 minutes after terminal R "OFF" or
- Service applications
- Power Management Switch off

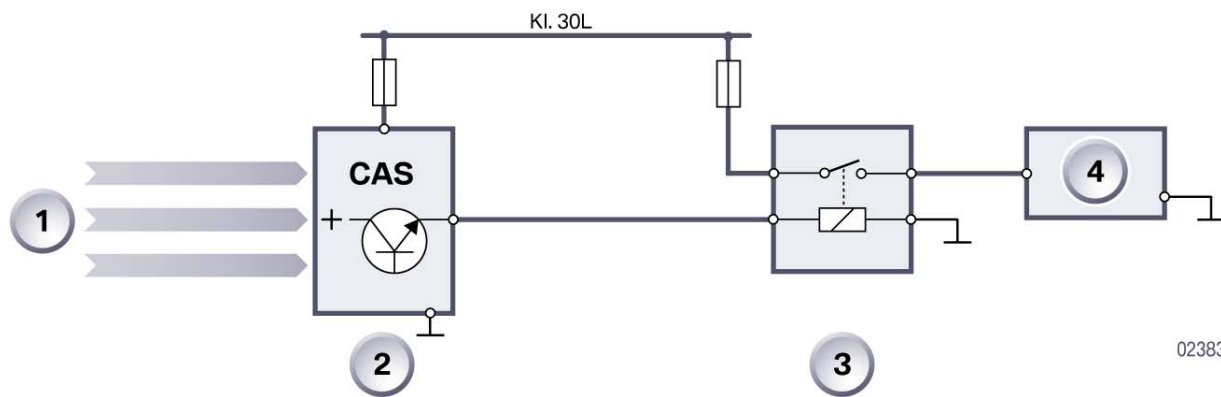

02383_02

Index	Explanation	Index	Explanation
1	Input signal/Terminal 30g OFF/ON	4	Electric Load
2	Car Access System (CAS)	KL30 L	Terminal 30 (load)
3	Terminal 30g Relay		

Micro-Power Module

In the same way as with terminal 30g, the micro-power module (MPM) facilitates defined deactivation of electric loads.

The MPM is installed in the spare wheel recess and operates in 3 modes, normal mode, sleep mode and service mode.

Normal Mode

All functions of the MPM are available in normal mode.

The MPM switches on/off the voltage supply to the electric loads involved in communication. Loads are switched on and off only when a fault occurs during the vehicle rest period. The MPM switches the voltage supply on and off in the following control units:

- Multi-audio system controller M-ASK
- Car communication computer CCC
- CD disc changer CDC
- DVD changer DVD

The supply voltage is switched on and off by means of a bistable (switchover type) relay.

The relay is set to "ON" when it leaves the factory. This type of relay has two positions, On and OFF. When ON voltage is passed from Fuse 57 through the MPM to the above consumers. When OFF, the connection to F57 is broken. This type of relay does not need power (coil energized) to maintain either switch position. Power is only needed to

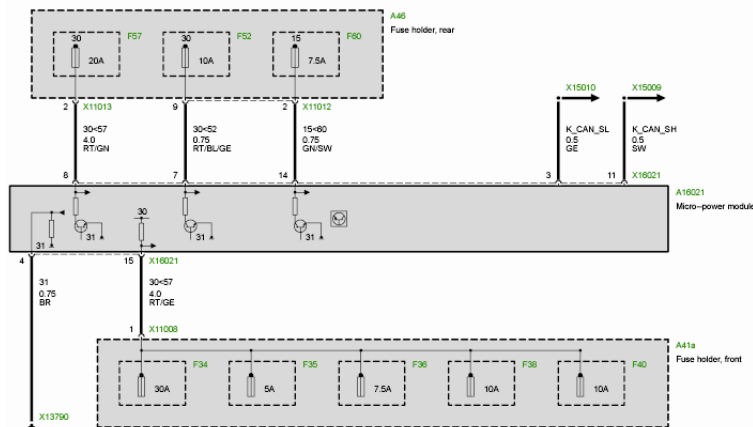

MPM Switch-on Conditions

The conditions required for switch-on are:

- Initial application of battery voltage ("first switch to power") to the MPM in the factory.

This action makes sure that the MPM has switched through, even without further conditions required for switch-on.

- Lock/unlock
- Terminal R ON
- Terminal 15 ON
- Changes in condition of door contacts or boot-lid-contact switch.

Switch-off Conditions

The conditions required for switch-off are:

- Off-load current at critical State of Charge (SoC - battery's limit of starting capability).
- "Auxiliary consumers OFF" signal from DME / DDE for off-load current of more than 80 milliampères (mA).
- SoC below battery's limit of starting ability.

All auxiliary consumers must be signed off immediately if:

- Undervoltage Battery voltage less than 9 volts (V) for a period of time greater than 60 seconds (s).
- Permissible number of "wake-up" actions in K-CAN exceeded.
- Bus activity after 60 minutes, even though vehicle has been parked up (terminal 0).
- The time is reset by switch-on conditions, e.g. by a door being opened.

This means: The vehicle is unable to go into sleep mode after terminal R is switched OFF.

There is no limit to the number of times this process can be repeated. It could thus cause the battery to become discharged!

When it is switched off, the bistable relay separates the consumers from the vehicle electrical system with a time lag of 5 minutes.

The switching-off process is interrupted if any of the switch-on conditions occurs during these 5 minutes.

The switch-on condition has priority over the switch-off condition.

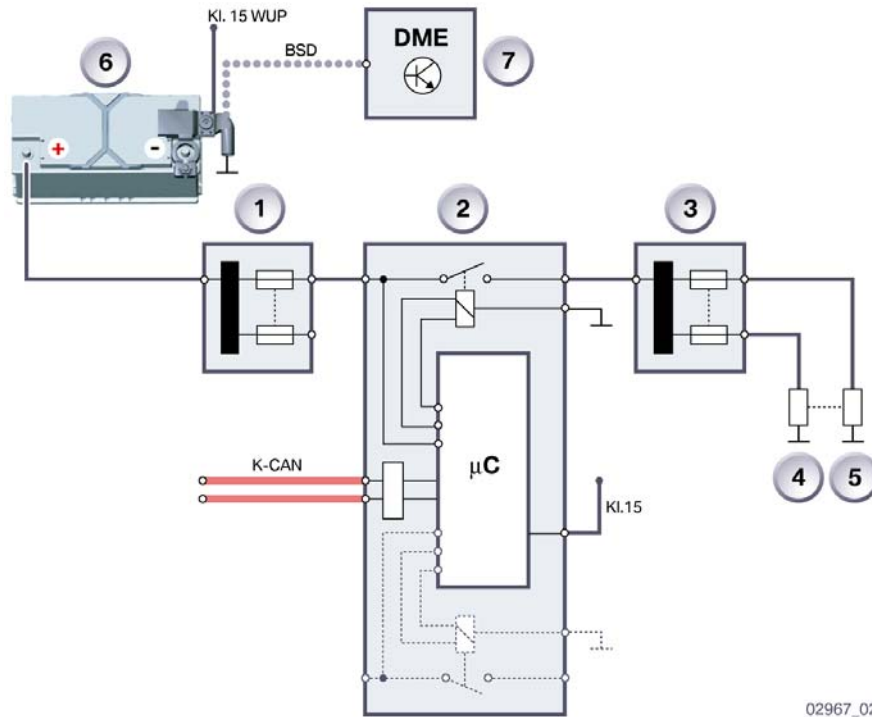

02967_02

Index	Explanation	Index	Explanation
1	Rear power distribution w/KL30g and KL15 relays	7	DME (ECM)
2	MPM	K-CAN	Body Controller Area Network
3	Front power distribution box	KL15	Terminal 15
4	Electrical Load	KL15 WUP	Terminal 15 Wake up
5	Electrical Load	BSD	Bit-serial Data Line
6	Battery		

The MPM communicates with the vehicle through the K-CAN and is supplied power by both a KL 30 and a KL 15. If terminal 30 voltage is lost, operation continues with the voltage supplied by terminal 15, and a fault is registered.

Sleep Mode

The MPM assumes sleep mode approximately 1 s after the K-CAN has gone into sleep mode. The current switching status of the relay is stored before the MPM assumes sleep mode.

The MPM is woken by the terminal 15 signal via the K-CAN or by activation of KL15.

On waking, the switching status of the relay last stored is reestablished.

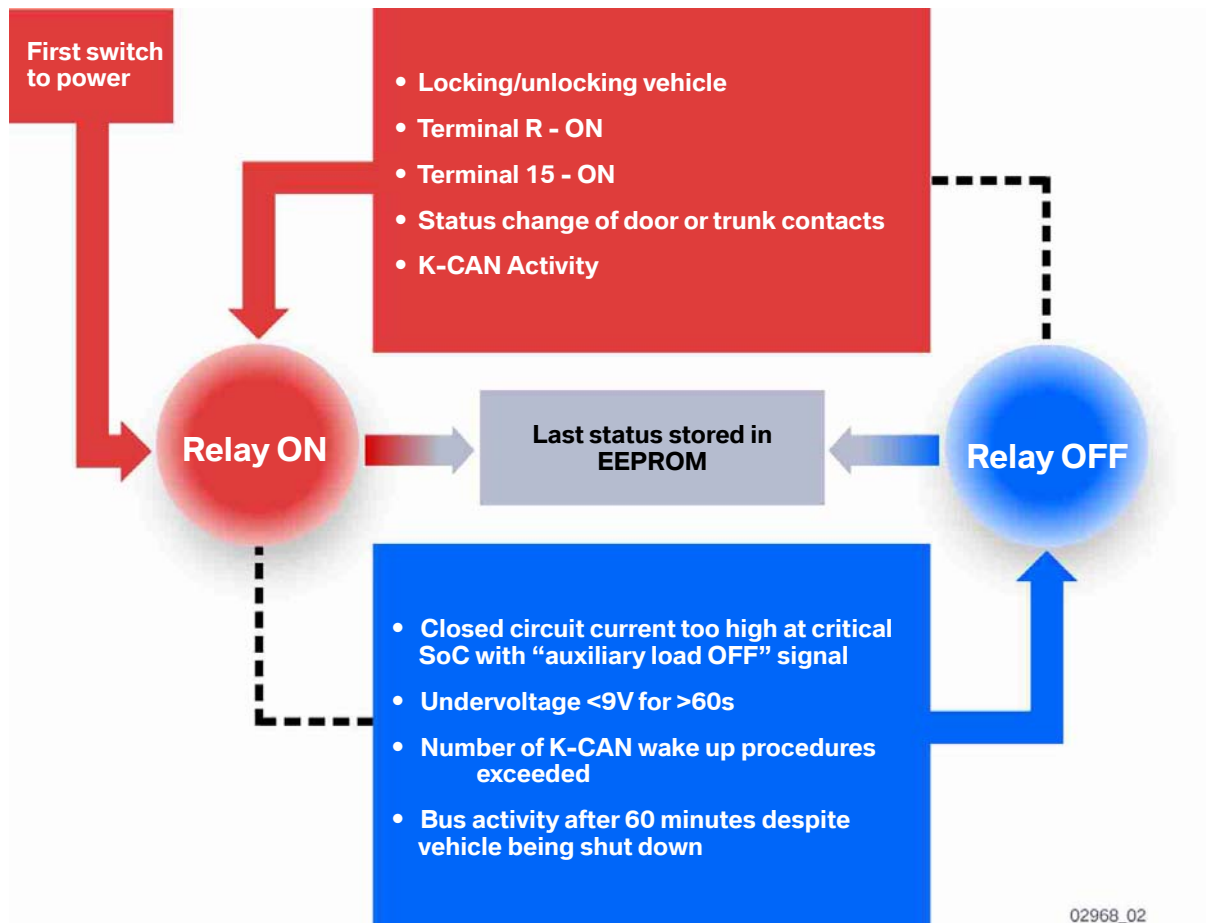

Service Information for MPM

A fault code is stored in the fault code memory when the MPM disconnects the electric loads from the vehicle electrical system. The following fault codes can be read out in diagnosis:

- Terminal 15 fault
- Deactivation with information on the switch-off condition

The information on the switch-off condition is stored in the info memory:

- Undervoltage
- Contact fault of relay contacts

Alternator

Bosch and Valeo alternators are installed in the 5 and 6 series. The alternators are fitted depending on the type of engine and equipment configuration. They differ with regard to their rating of 140 A and 170 A and are air-cooled.

Digital Motor Electronics

The power management software is contained in the DME. When the vehicle is at rest, the IBS is partially responsible for power management.

The tasks of the power management system include:

- Adaptation of the alternator charging voltage.
- Idle speed boost for increasing the power output of the alternator.
- Reduction of peak loads in the event of a shortfall in coverage provided by the vehicle electrical system.
- Deactivation by means of bus messages of electric loads such telephone, on reaching the start capability limit of the vehicle.
- Closed-circuit current diagnosis.

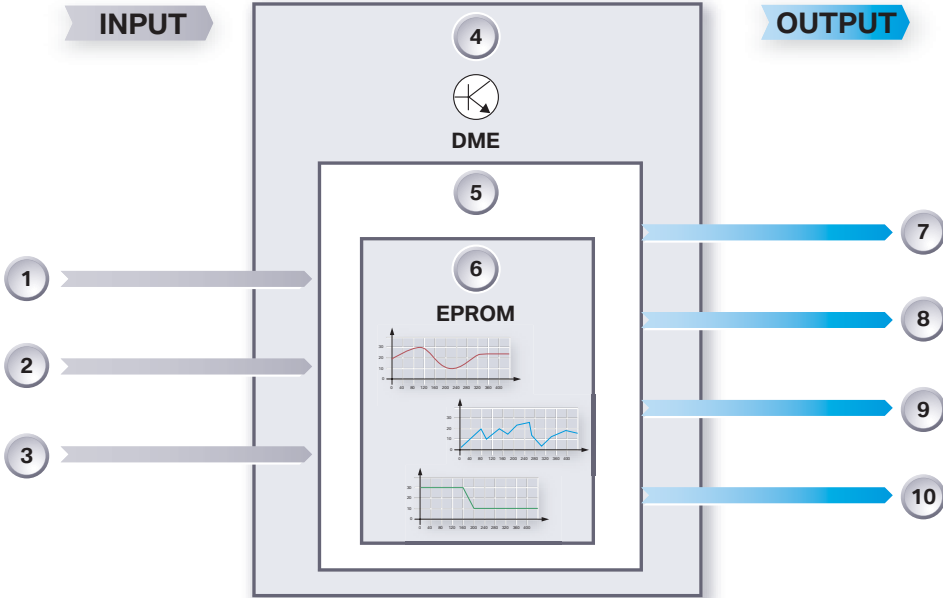

VS223_02373_02b

Index	Explanation	Index	Explanation
1	Battery Voltage	6	EEPROM with maps for voltage, current & temp
2	Current input	7	Idle speed control
3	Temperature input	8	Specified alternator charging voltage
4	DME (ECM)	9	Deactivation of electrical loads
5	Power management	10	Peak load reduction

Variable Battery Charging Voltage

The variable battery charging voltage on system ensures improved charging management of the battery in unfavorable driving situations. The power management controls the temperature-dependent voltage for the charging voltage of the alternator via the BSD line.

Idle Speed Boost

The idle speed can be increased in situations where the battery does not cover power requirements. When the specified voltage alone is no longer sufficient, the DME boosts the idle speed corresponding to the engine status.

Reducing Peak Loads

The peak load of the vehicle electrical system is reduced when there is still a shortfall in battery coverage despite boosting idle speed.

Peak load reduction is realized by:

- Reducing power output, e.g. by correspondingly controlling the clock cycles of the rear window defogger.
- If reducing the power output is not sufficient, individual electric loads can be switched off in extreme situations.

Electric Load Cutout

The electric loads in the E60, E63 and E64 are divided into the following categories:

- Comfort loads, e.g. window defogger, seat heating, steering wheel heating. Electric loads switch off automatically after engine "OFF." These electric loads can be activated again after the vehicle has been restarted.
- Legally required auxiliary electric loads, e.g. side lights, hazard warning lights. Legally required auxiliary loads must be operational for a certain period of time after engine "OFF." These legally required electric loads are not switched off even on reaching the start capability limit of the battery.
- Auxiliary electric loads, e.g. independent ventilation, communication components such as central information display, telephone, telematic services. Auxiliary loads can be switched on after engine "OFF." The comfort electric loads switch off automatically on reaching the start capability limit of the battery. Switch-off is requested by the DME in the form of a CAN message.
- System-related after-running loads, e.g. electric radiator fan. System-related after-running loads can maintain operation for a defined period of time.

Battery Charge Management

There are two “counters” in the power management module. One counter is responsible for the battery charge and the other is for the battery discharge level. The state of charge (SoC) of the battery is formed by the difference between the charge acceptance and draw level. The power management receives the corresponding data from the IBS via the BSD. The power management calculates the current SoC value on restarting the vehicle.

Battery - State of Health

The IBS measures the dip in the battery terminal voltage and the starting current of the starter when the vehicle is started. The IBS detects vehicle start based on current draw in excess of 200 A. The engine running signal is made available by the DME (ECM). Internal resistance of the battery is calculated from the current and voltage dip.

Starting current and voltage dip values determined during the startup process are transferred via the BSD to the DME (ECM). From this data, the power management calculates the state of health (SoH) of the battery.

Data Transfer to the IBS

The following data are transferred via the BSD to the IBS before the DME assumes sleep mode:

- State of charge of the battery SoC
- State of health of the battery SoH
- Outside temperature
- Available discharge level
- Terminal 15 wake-up enable
- Terminal 15 wake-up disable
- DME close

Closed-Circuit Current Diagnosis

A fault code is stored in the DME when the battery current exceeds a defined value during the vehicle rest phase. The vehicle should be analyzed accordingly.

Terminal 30g Relay

The terminal 30g relay is actuated by the CAS at an excessively high closed-circuit current or on reaching the start capability limit of the battery.

Bus Systems

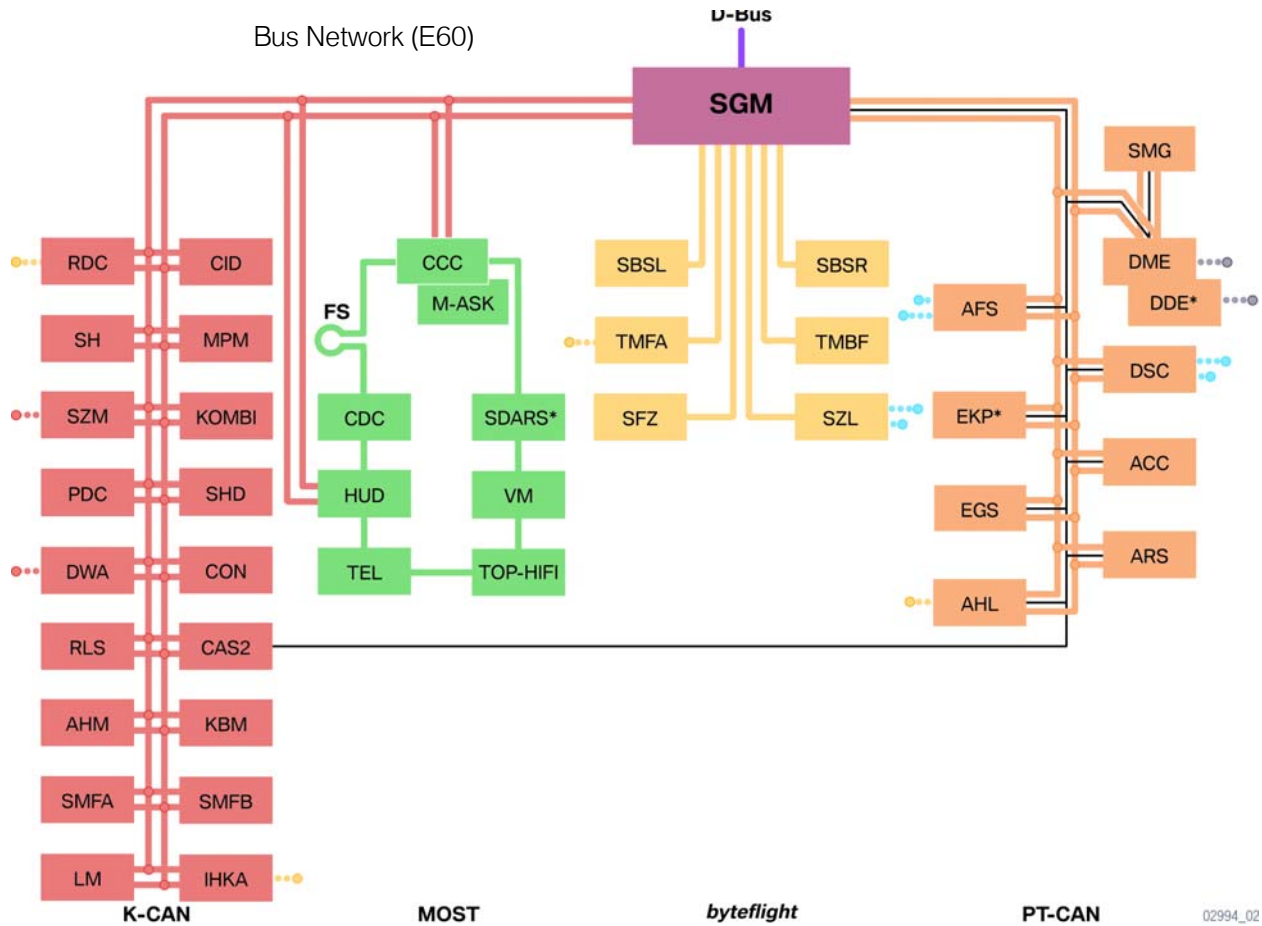

K-CAN

K-CAN Changes

In the E60, the bus systems K-CAN S and K-CAN P of the E65 were combined to form the K-CAN.

The car access system CAS is no longer used as a repeater between K-CAN S and K-CAN P. CAS is now only a K-CAN user. The internal designation is CAS 2.

The instrument cluster and the central information display are now connected to K-CAN. They no longer serve as a gateway between K-CAN S and MOST.

The door modules are no longer connected to K-CAN P but rather to byteflight.

The controller CON is connected directly to K-CAN and no longer via the centre console switch centre SZM.

MOST

Most Changes

MOST has less users than on the E65. Components such as the instrument cluster and central information display CID are connected to other bus systems. The MOST additionally features the satellite radio (SDARS).

A large MOST system extending up to the luggage compartment is installed if the E60 is equipped with a telephone, or Top HiFi system.

byteflight

byteflight Changes

The SIM and ZGM functions have been combined in the SGM. The door modules adopt the functions of the front door satellites.

byteflight E65	byteflight E60/ E63/E64
Central Gateway Module	Safety and Gateway Module (SGM)
Safety and Information Module	Combined in SGM
Steering Column Switch Center (SZL)	SZL
Center Vehicle Satellite (SFZ)	SFZ (E64 uses SFZ-R)
A-pillar satellite, left SASL	not used
A-pillar satellite, right SASR	not used
Front door satellite, left STVL	Driver's door module TMFA
Front door satellite, right STVR	Passenger door module TMBF
B-pillar satellite, left SBSL	SBSL
B-pillar satellite, right SBSR	SBSR
Driver's seat satellite SSFA	not used
Passenger seat satellite SSBF	not used
Rear seat satellite SSH	not used

PT-CAN

No Changes

Bus System Parameters

Bus System	Data Rate	Bus Structure
K-CAN	100 kbps	Linear/two wire - copper
PT-CAN	500 kbps	Linear/two-wire - copper
byteflight	10 Mbps	Star/Fiber optic
MOST	22.5 Mbps	Ring/Fiber optic
D-Bus	10.5/115 Kbps	Linear/Single-wire

Sub-Bus Systems

LIN-Bus

The LIN-bus was developed to provide a standard network for the automobile industry.

The LIN-bus is a standardized serial single-wire bus system. The LIN bus facilitates fast and simple data transmission. The use of LIN-bus technology reduces the number of lines in the vehicle.

LIN-bus systems in E60

A typical LIN-bus system includes the following components:

- 1 Main Controller
- Several Server Units
- Single-wire line

On the E60, the LIN bus is used on the IHKA system, the SBFA and the AHL system.

Main Controller	Server Unit(s)
IHKA	Flap (stepper) motors and Blower motor
Door Module	Driver's Switch Block (SBFA)
AHL (Adaptive Head Lights)	Stepper Motor Controller (SMC)

The LIN-bus uses a bi-directional single-wire bus line as the transmission medium. The bus contains only one Main Controller while many server units are possible. The transfer rate on the LIN-bus can be up to 19.2 kBaud.

The following transfer rates are possible:

9.6 kBaud for IHKA 19.2 kBaud for other systems

LIN-Bus Main Controller

The LIN-bus Main Controller transfers the control unit requests to the server units of the system. The LIN-bus Main Controller controls the message traffic on the bus line.

LIN-bus server units of the air conditioning systems include:

- Actuator motors for the air distribution flaps
- Blower controller

The LIN-bus server units wait for commands from the LIN-bus Main Controller and communicate with it only on request.

F-CAN

The F-CAN enables fast data transfer between the chassis related system components (e.g. active steering, DSC etc.)

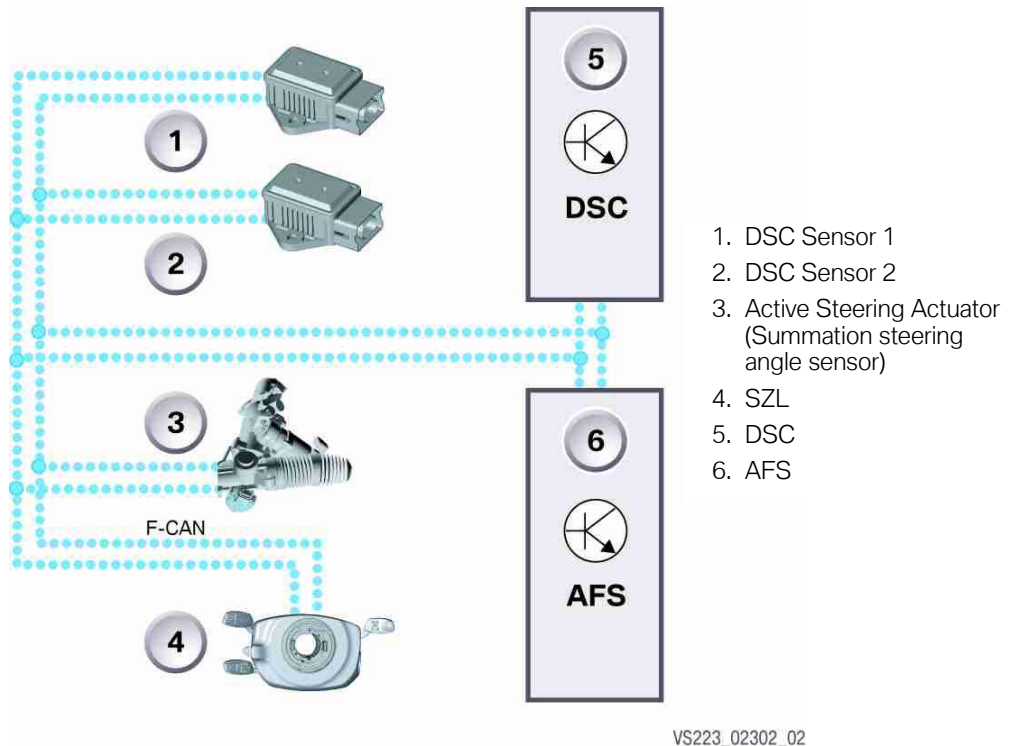

BSD (Bit-Serial Data Interface)

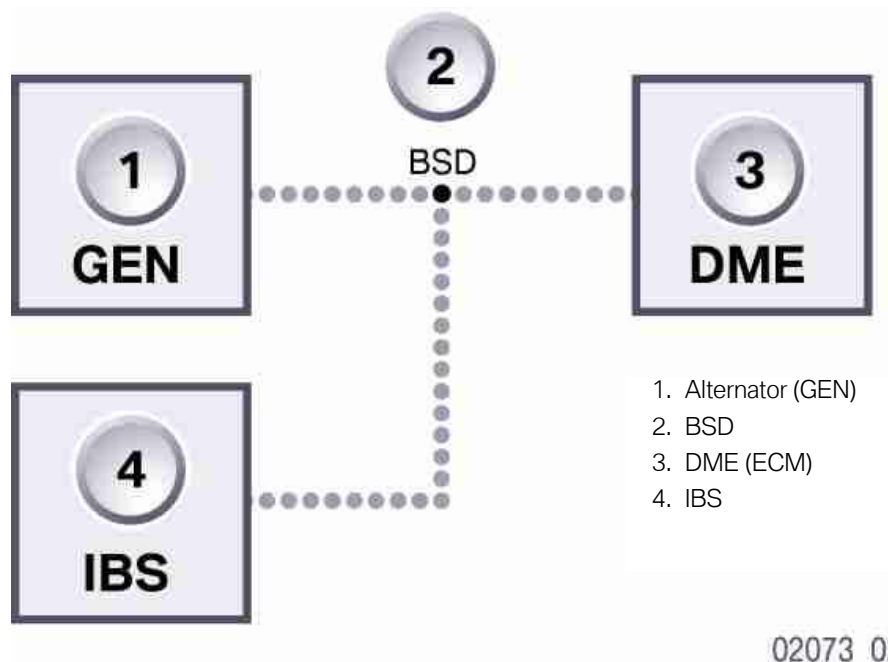

Sub-Bus System Parameters

Sub-bus system	Data rate	Bus Structure	Components
BSD	9.6 Kbps	Linear/Single wire	DME, IBS, Alternator
DWA K-Bus	9.6 Kbps	Linear/Single wire	UIS, DWA Siren w/tilt sensor
K-Bus seat	9.6 Kbps	Linear/Single wire	Seat adjustment switch unit, Center console switch unit
LIN Bus A/C (IHKA)	9.6 Kbps	Linear/Single wire	IHKA, All IHKA stepper motors, blower motor
LIN Bus RDC (not for US)	9.6 Kbps	Linear/Single wire	RDC, wheel arch antennae
LIN Bus AHL	19.2 Kbps	Linear/Single wire	AHL Control unit, SMC
LIN Bus TMFA	19.2 Kbps	Linear/Single wire	Door module, Driver's switch block
F-CAN	100 Kbps	Linear/Two wire	AFS, ARS, yaw rate sensors, SZL, DSC, LWS

MOST Connector Junction

The MOST connector junction facilitates quick connection of new control units.

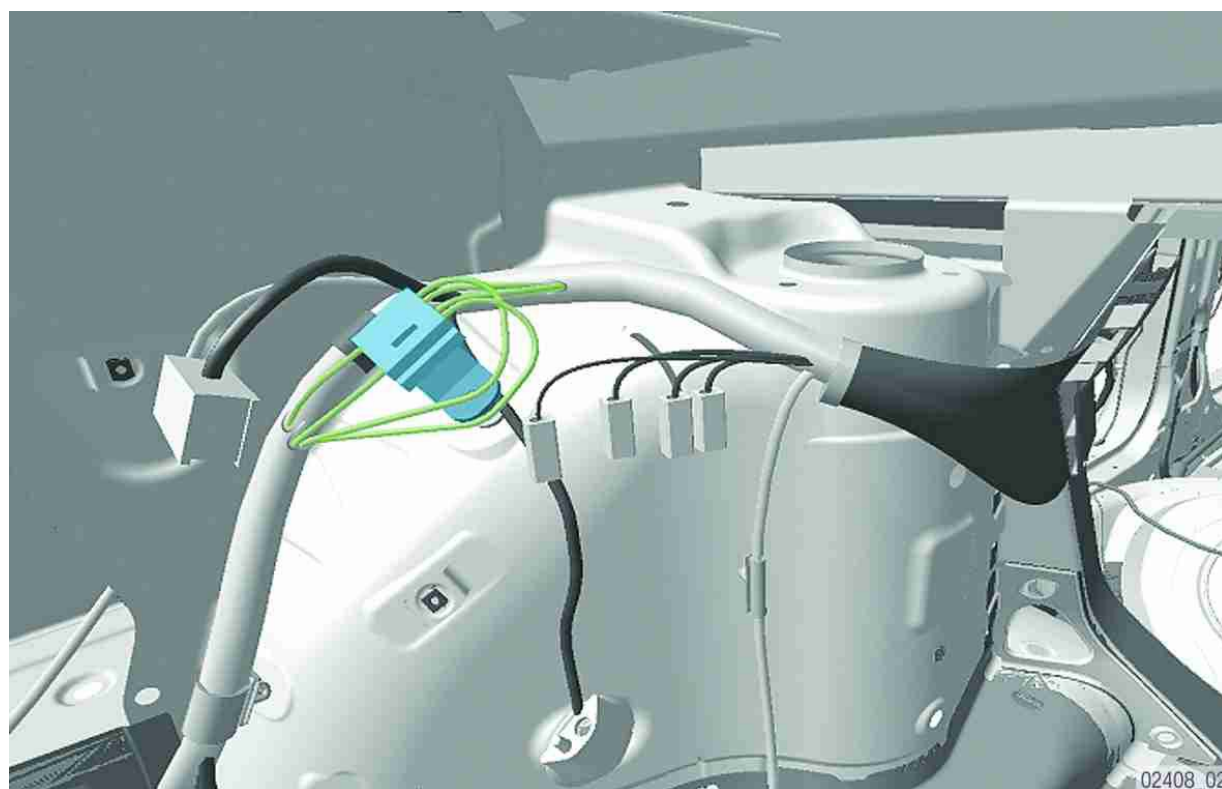

Bus System Overview (E61)

The bus system on the E61 contains additions to K-CAN. EHC and HKL are added with the MDS control unit for the panoramic sunroof.

The MOST bus, byteflight and PT-CAN have remained mostly unchanged.

The sub-bus systems are as used on E60.

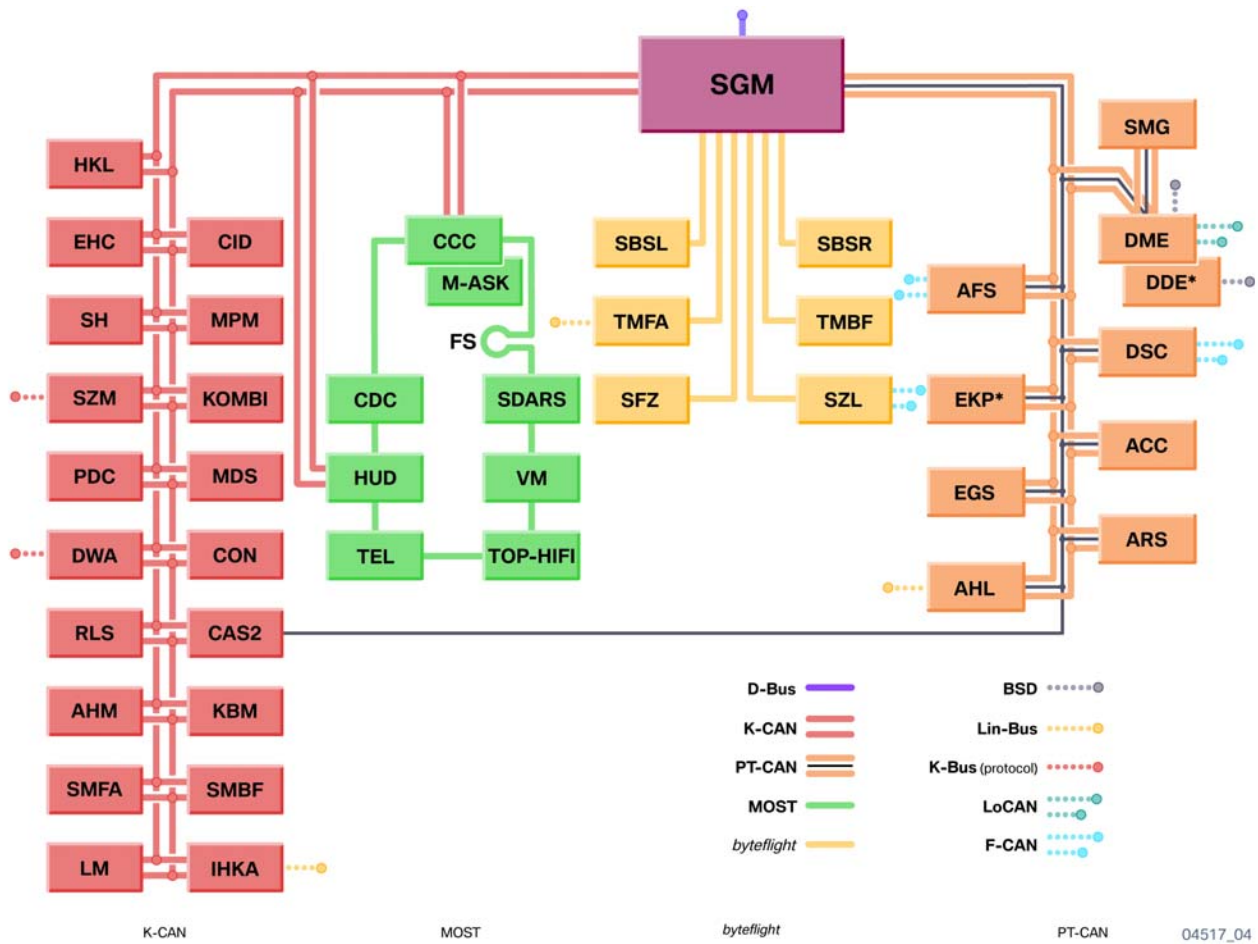

Bus Systems (E63 and E64)

The bus system on the E63/E64 is mostly the same as the E60. Due to the sunroof design in the E63, there is no SHD module but rather an Multi-Drive Sunroof module (MDS). Also, there is no passenger seat module on the E63/E64, so the K-CAN only has the SMFA.

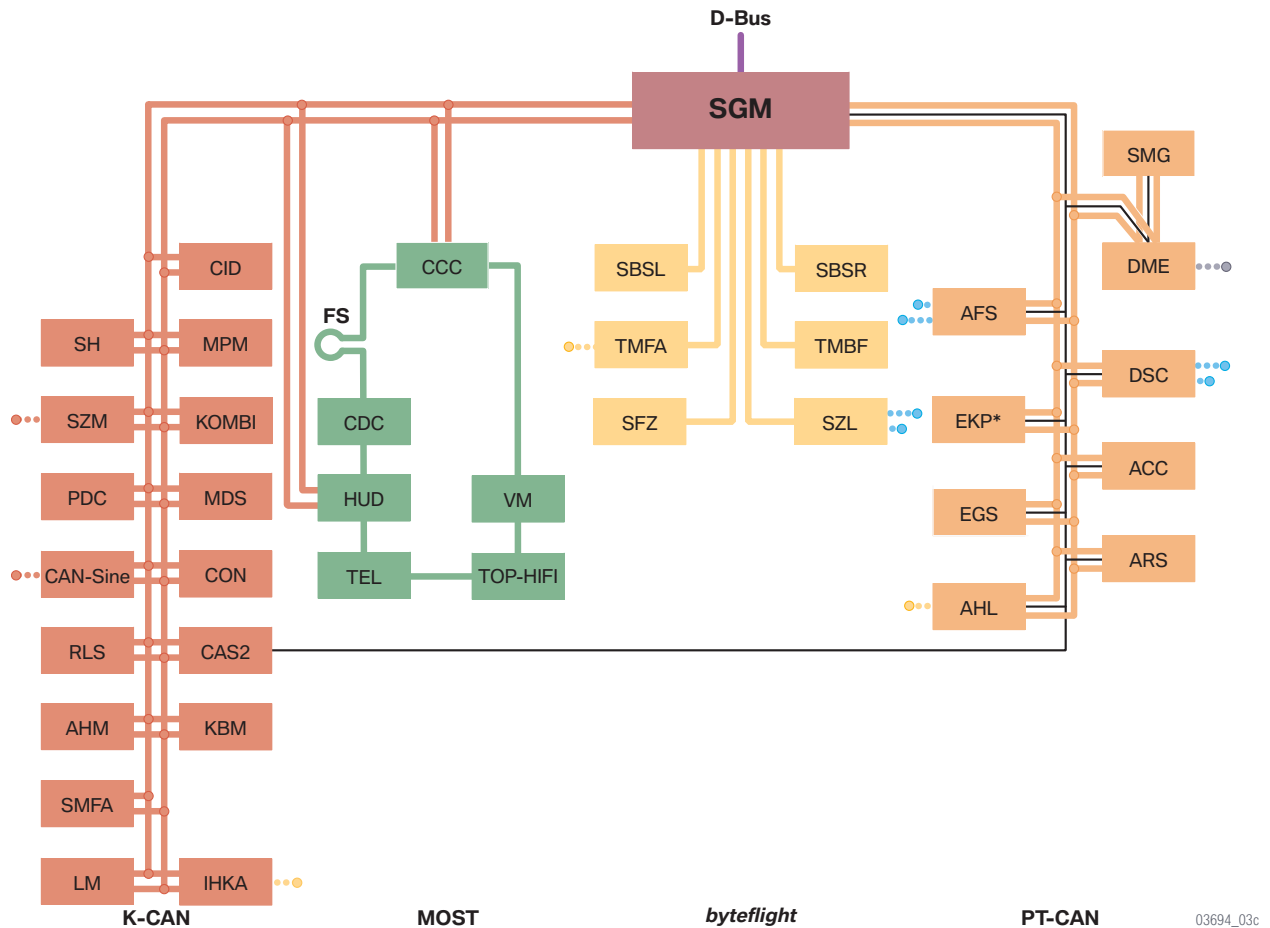



Workshop Exercise - Battery and Power Supply

Using an instructor designated vehicle, connect appropriate diagnostic equipment and perform complete vehicle short test.

Describe how to access the test module for “battery replacement register”:

What is the importance of performing this test module after replacing a battery?

List the last battery replacement mileage for:

Last _____

Second _____

Third _____

Fourth _____

Go to the “closed circuit current” test module in the service functions menu and record the time/current values below:

0 - 80ma _____

80 - 200ma _____

200 - 1000ma _____

> 1000ma _____

How is this information useful in diagnosis?

Can you reset the “histogram” in this test module?



Workshop Exercise - Intelligent Battery Sensor

Using an instructor designated vehicle, connect appropriate diagnostic equipment and perform complete vehicle short test.

Locate and Identify the IBS in the vehicle. Connect oscilloscope to BSD

What is observed regarding the BSD signal? (Voltage etc.)

Disconnect BSD connector and measured signal on both ends of the open connection. Compare both signals.

What is observed regarding the signal from the DME and the IBS?

Reconnect BSD connector and monitor signal of BSD when entering sleep mode.

What happens to the BSD when entering sleep mode and How long does the BSD stay active?

Perform the test plan B1362 as outlined in the DISplus.

Why is it important that replacement batteries be the same type and capacity as the factory installed battery?

What measurements are performed directly by the IBS?



Workshop Exercise - Terminal 30g Relay

Using an instructor designated vehicle, connect appropriate diagnostic equipment and perform complete vehicle short test.

Remove Terminal 30g relay and perform complete vehicle short test.

What control modules were not identified during the short test?

What control module is responsible for switching the control circuit of the KL30g relay?

With the KL30g relay still removed attempt to start the vehicle.

Does the vehicle start? Why or Why not? What circuits are affected?

How long after terminal R "OFF" is the terminal 30g relay switched off?

What conditions will cause the KL30g relay to be switched on when in sleep mode?



Workshop Exercise - Micro Power Module

Using an instructor designated vehicle, connect appropriate diagnostic equipment and perform complete vehicle short test.

Access correct ETM for MPM circuit.

What fuse supplies the load circuit power for the MPM?

What circuits are supplied by the MPM?

Unplug the MPM and observe which circuits are inactive.

Which circuits are inactive with MPM disconnected?

Using the oscilloscope obtain the scope pattern (dual trace) for pins 3 and 11 (K-CAN) of the MPM.

What is observed regarding this scope pattern? (voltage etc)

What are the pin numbers of the M-ASK that provide K-Can communication?

If the M-ASK is not recognized during the short test would the OPSS tester be useful?



Classroom Exercise - Review Questions

1. What are the power management tasks performed by the DME?

2. Under what conditions (concerning the electrical system) does the DME boost the idle?

3. How does the DME determine SoC?

4. What is the difference is between SoC/SoH?

5. How does the IBS detect starter operation?

6. Explain IBS wake-up disable.

7. Which control module is the gateway from the K-Can to the MOST?



Classroom Exercise - Review Questions

8. Name the Bus or sub-bus systems that consist of two wires.

9. What is the purpose of the MOST connector junction?

10. What are some of the symptoms of a failed MOST Bus?

11. Which control unit calculates the SoC/SoH of the battery while the engine is running?

12. How often is the battery conditioned monitored while the vehicle is "OFF"?

13. How does the IBS signal the DME of significant changes in SoC during "OFF" time?



Workshop Exercise - Diagnosis

Vehicle/Model _____ Chassis #: _____

Complaint:

Cause:

Correction:
