

Mechatronic Replacement Hints

Our mechatronic units

The CTSC
the california transmission
supply company, LLC

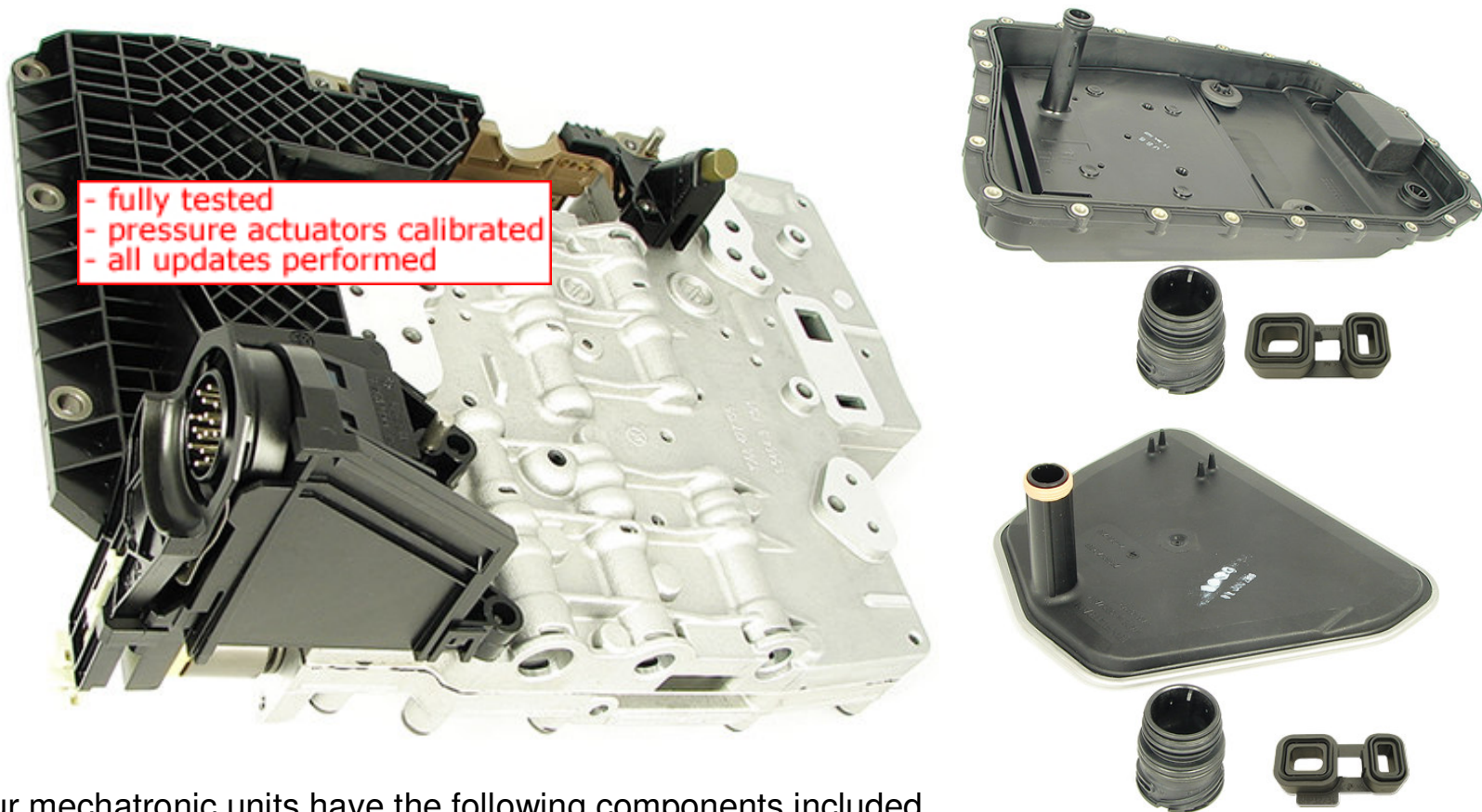

Our mechatronic units have the following components included.

* Mechatronic units for vehicles with plastic oil pan include a new oil pan, sealing sleeve and mechatronic seal adapter.

* Mechatronic units for vehicles with steel oil pan include a new filter, sealing sleeve and mechatronic seal adapter, the oil pan gasket needs to be ordered separately.

Mechatronic Replacement Hints

Removing harness and sleeve

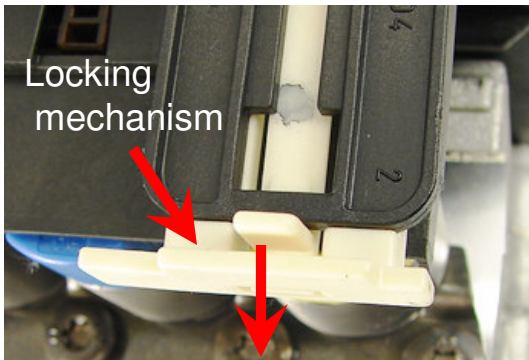

- Secure vehicle against rolling, secure wheels with wheel chocks.
- Drain transmission fluid and remove the transmission oil pan.
- Unlock and disconnect the vehicle connector from the transmission.

Note



- Pull the sealing sleeve locking mechanism to the unlocked position. The locking tab is located on the bottom of the mechatronic below the sealing sleeve.
- Remove the sealing sleeve.

Mechatronic Replacement Hints

Secure the emergency release lever

The CTSC
the california transmission
supply company, LLC

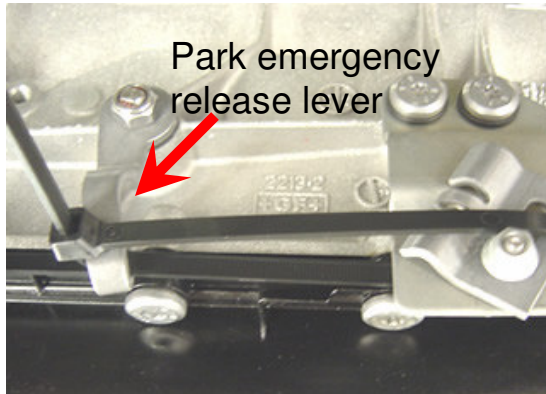

- On E-shift applications only (vehicles with emergency release cable). Use a wire tie or mechanics wire and secure the emergency release lever in a slight backward position as shown.

Note

- By moving the emergency release lever backward, the transmission is no longer in the park position. Secure against rolling, apply parking brake and secure **wheels with chocks**.

Note

- During removal and handling of the mechatronic apply special care not to bump, drop or rough handle the unit especially in the area of MV2 solenoid.

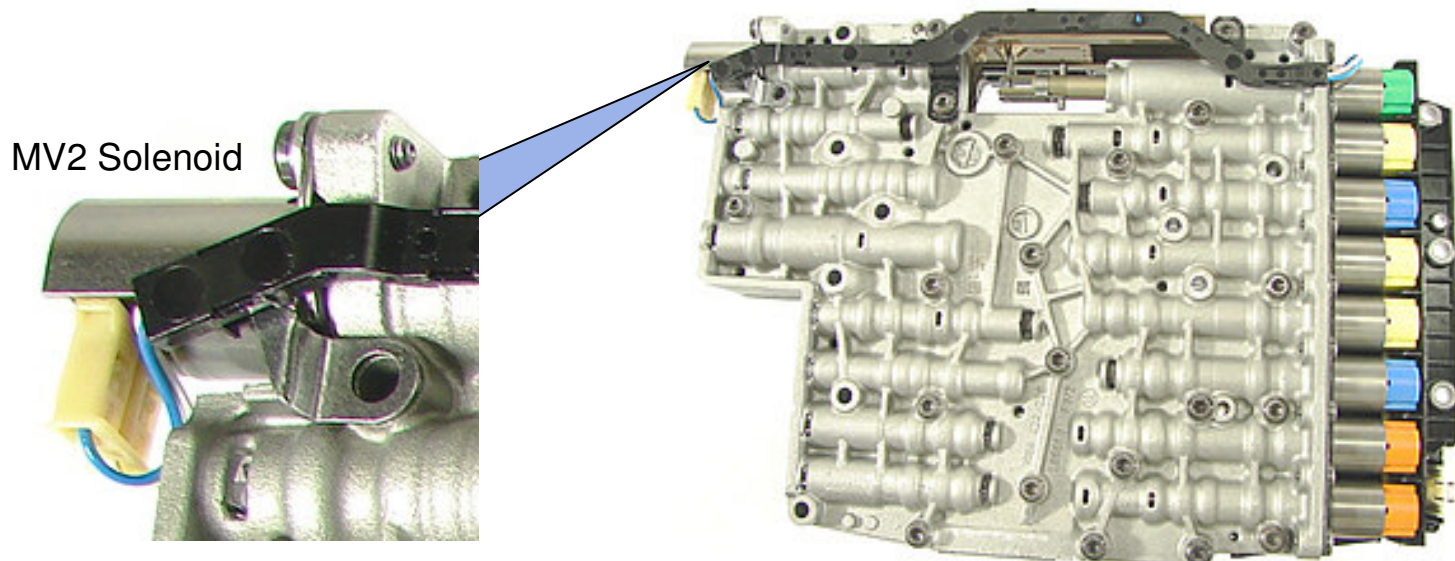

Mechatronic Replacement Hints

Removing the mechatronic

Note

- During removal and handling of the mechatronic apply special care not to bump, drop or rough handle the unit. The pressure actuator and solenoids are easily damaged and can cause erratic operation or even result in transmission damage.

Release and remove the screws **1** through **10** or **1** through **13** as shown in the schematic below to remove the mechatronic.

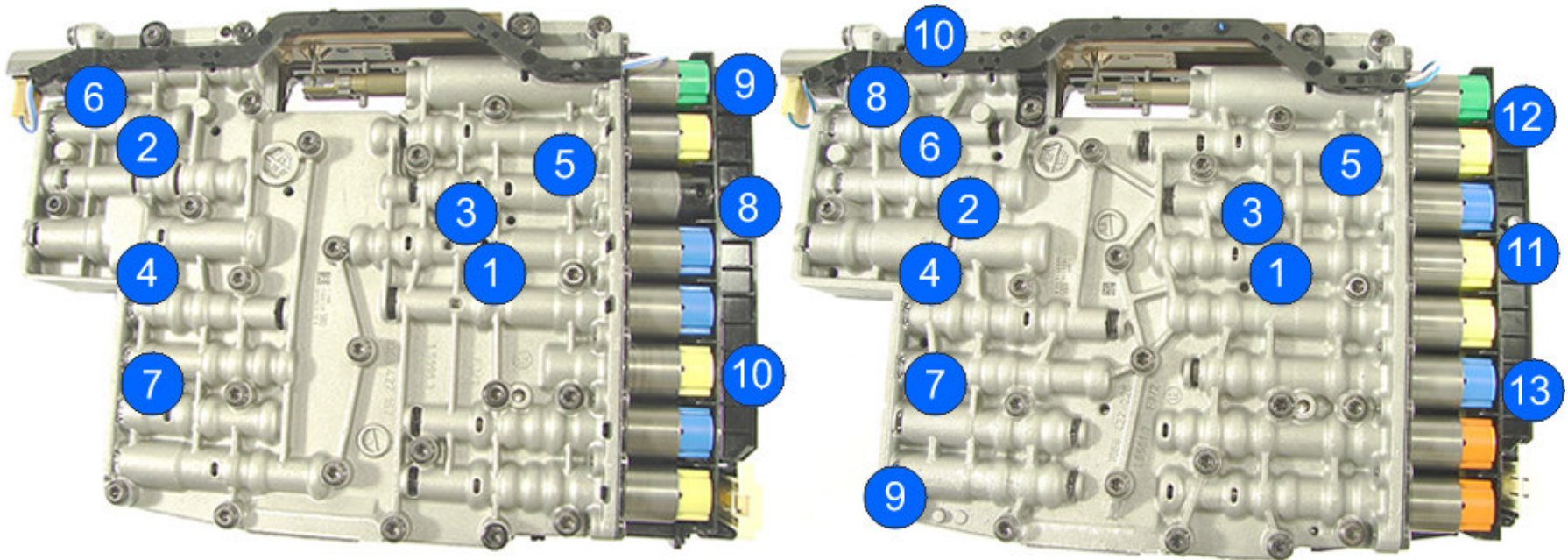

Mechatronic Replacement Hints

Adapter replacement

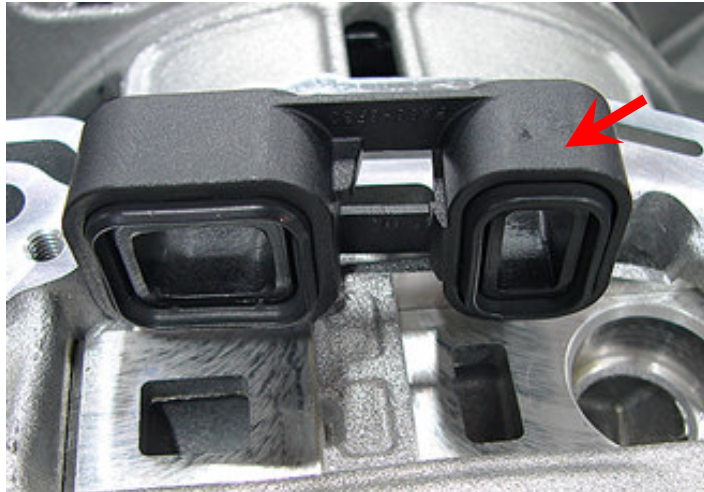

- Remove the mechatronic adapter from the transmission housing and replace it with the new one that came with the mechatronic. Use transmission fluid to coat the adapter seals.
- The 6HP19-21 and the 6HP26-28-32 adapters are different in their height. Check the height of the adapter without the seals installed.

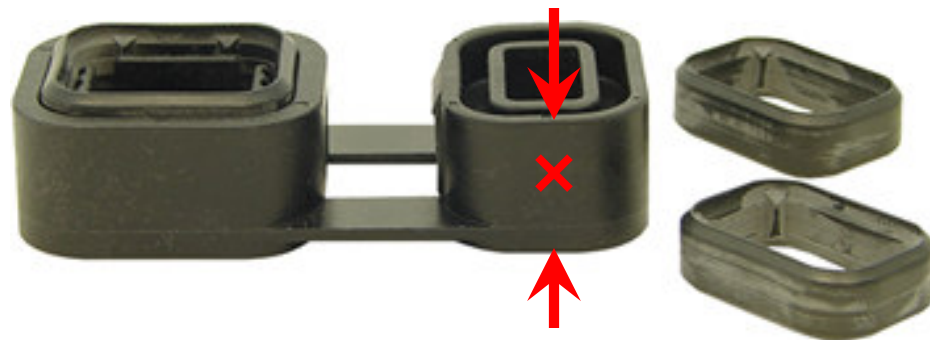

Note

- Adapter height **X** on 6HP19 & 21 = **15.4 mm ± 0.1 mm**
- Adapter height **X** on 6HP26 & 28 & 32 = **14.4 mm ± 0.1 mm**

Mechatronic Replacement Hints

Park cylinder rod or selector valve alignment

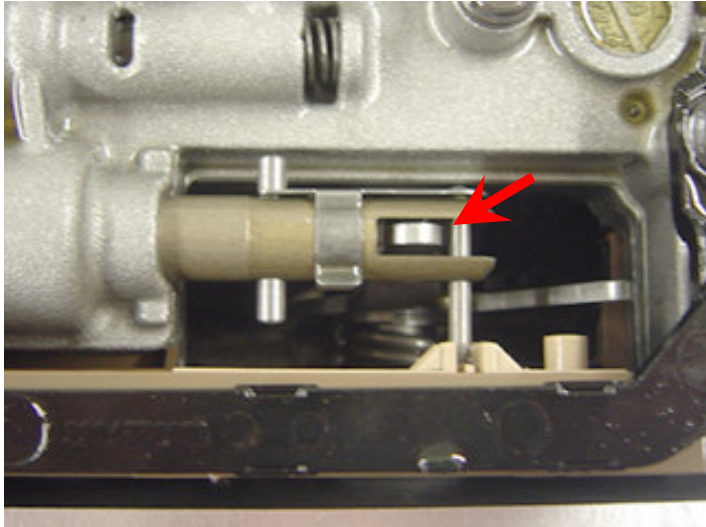

E - shift

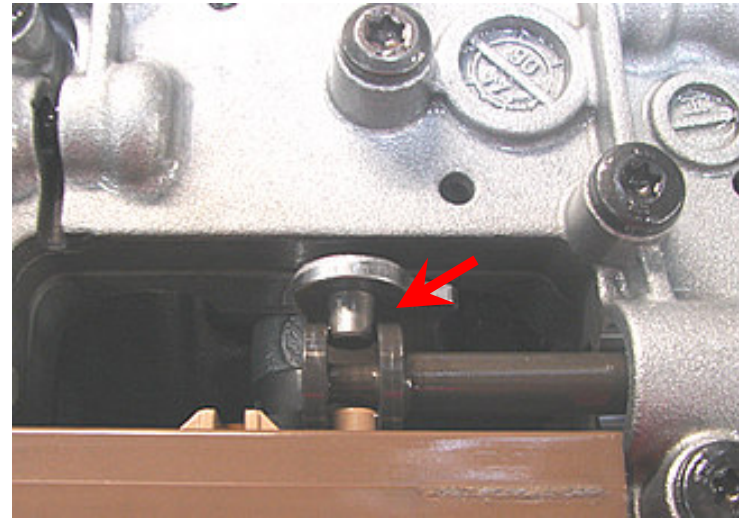

M - shift

- When installing the replacement mechatronic make sure the park cylinder rod on E-shift or the manual valve on M-shift is properly engaged before installing any of the mechatronic mounting bolts.

Note

- If the screws were installed without the park cylinder or manual valve in place, do not force the components in place, irreversible damage will occur. Remove all mechatronic mounting screws and start from the beginning.

Mechatronic Replacement Hints

Installing the mechatronic mounting bolts

Note

- Use hand tools – do not use power tools for screw installation. Improper torque of the mechatronic mounting screws will cause erratic transmission operation.

First install and turn screw 1 and 4 alternately until seated then install all other screws until they make contact with the mechatronic. After all screws are installed, tighten screws in order 1 through 10 or 1 through 13 as shown in the schematic below.

Torque for screws is **8 NM ± 0.8 Nm**.

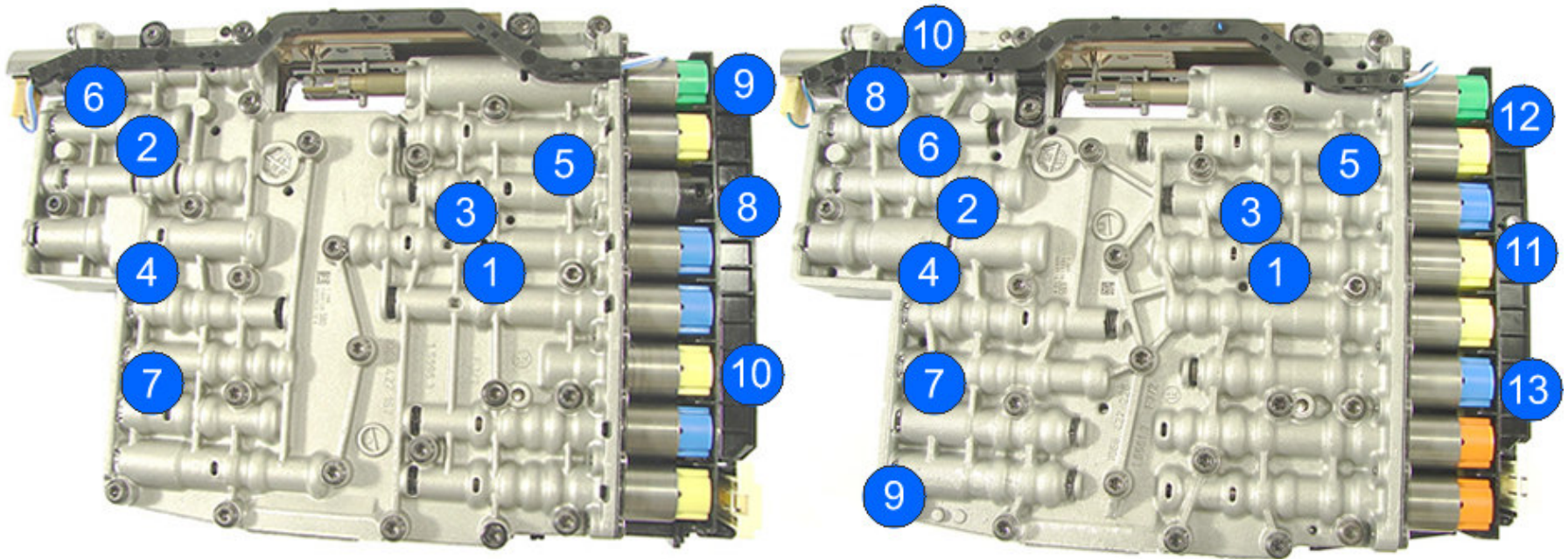

Mechatronic Replacement Hints

Sleeve installation

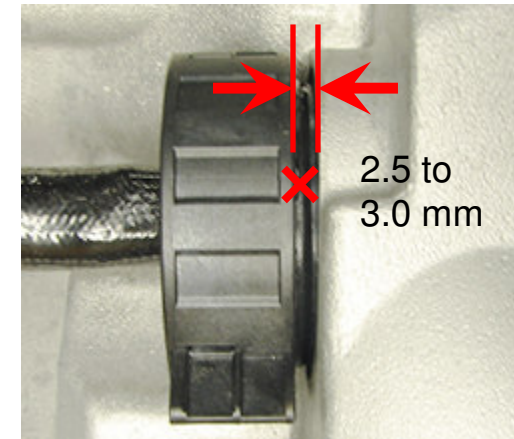
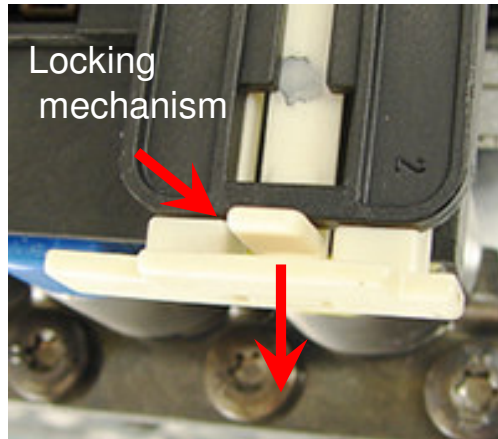

- Unlock the sealing sleeve locking mechanism and install the sealing sleeve with the locating tab properly aligned with the mechatronic. Use transmission fluid to lubricate the seals for installation. After the sleeve is properly seated, push the locking mechanism to the locked position. Install the vehicle connector plug and check that the sleeve is properly seated. The gap **x** should be between **2.5 to 3.0 mm**.



Note

Attention
ESD sensitive device.
Do not touch the pins
of the electrical connector.



Mechatronic Replacement Hints

Oil pan torque sequence

- Install the oil pan and attach all screws until they just make contact with the oil pan. After all screws are installed, tighten screws in order **1** through **24** or **1** through **21** as shown in the schematic below.

The tightening torque for screws on a plastic oil pan is **10 Nm ± 1.0 Nm**.

The tightening torque for screws on a steel oil pan is **12 Nm ± 1.0 Nm**. (steel pan not pictured)

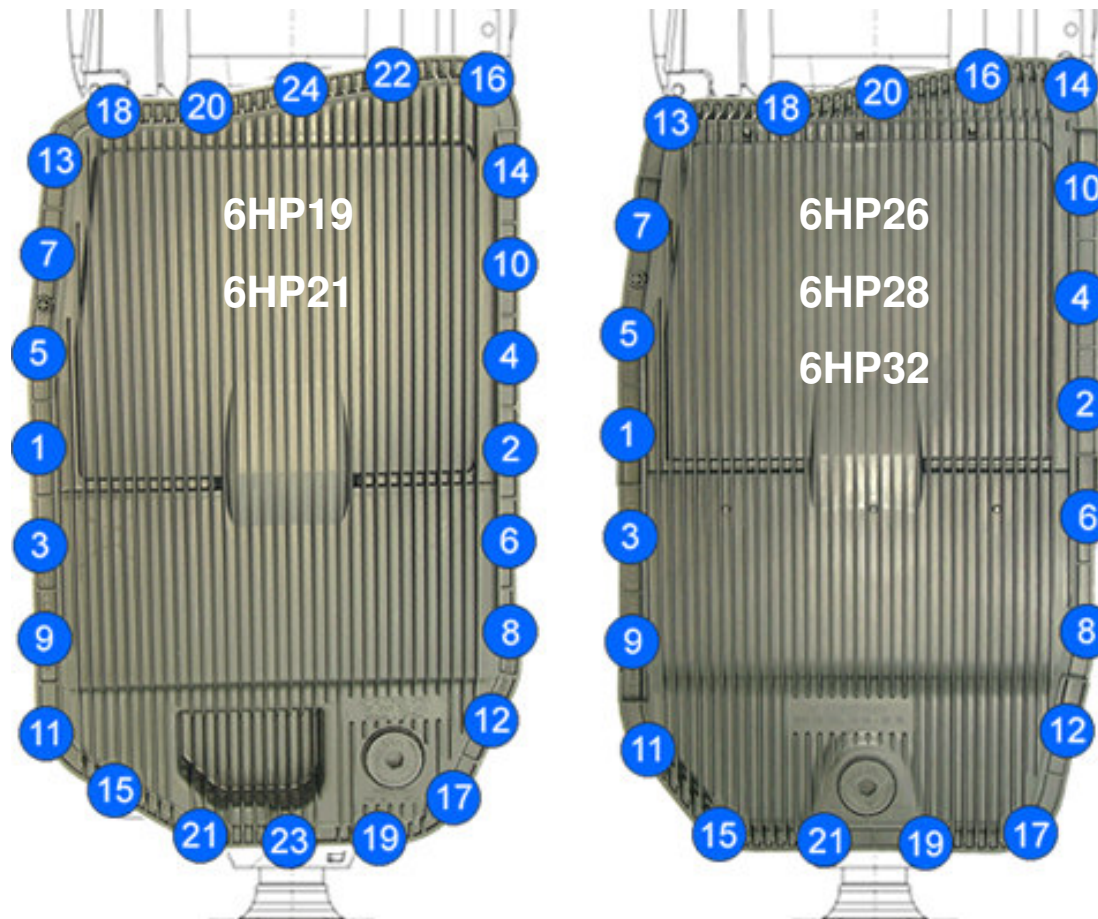

Mechatronic Replacement Hints

Emergency release cable adjustment

The CTSC
the california transmission
supply company, LLC

- E-shift vehicles only, remove the tie strap or wire that held the emergency park release lever in the backwards position and adjust cable as follows.

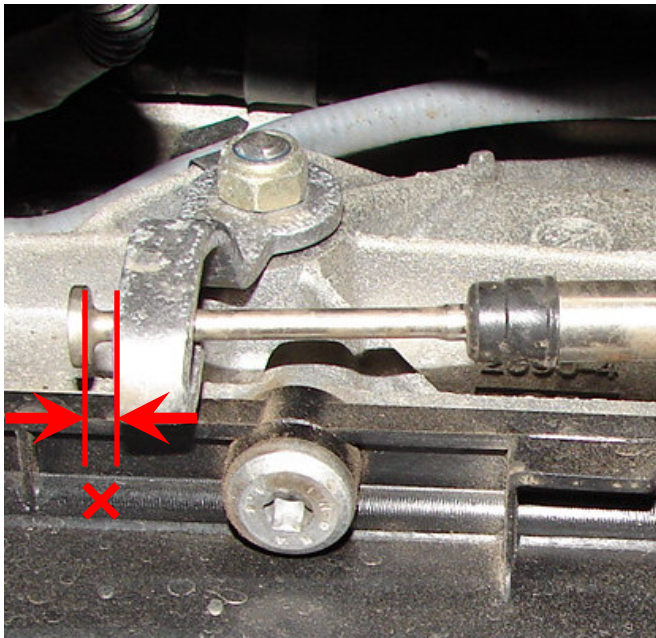

With the emergency cable released the clearance **X** indicated above must be adjusted to **1.0 to 2.0 mm**.

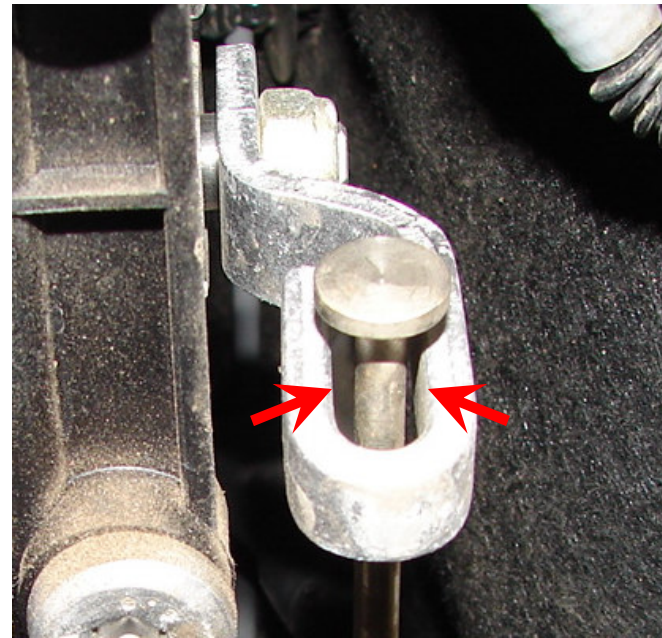

The cable should not touch the lever at any time, even if the lever is moved back and forth. If the cable does come in contact then check for a bent lever or a bent cable bracket.

Mechatronic Replacement Hints Programming

- If the mechatronic was not previously programmed with vehicle specific software then this must be performed at this time. Operating the vehicle in failsafe mode may cause transmission damage. If on site programming tools are not available then the vehicle must be transported to a vehicle specific dealer for programming.

Note

- The transmission does not contain transmission fluid and therefore should only be transported on a flat bed tow truck.

Mechatronic Replacement Hints

ZF LifeguardFluid

The CTSC
the california transmission
supply company, LLC



Notes on transmission fluid

- Use of **ANY** transmission fluid other than ZF LifeguardFluid can cause transmission slippage, harsh shifting, noise, lock-up clutch cycling and reduced service life.

LifeguardFluid6 S671 090 255

all 6HP19,
all 6HP19X **except for Audi Q7**,
all 6HP21, 6HP21X, 6HP26, 6HP26X,
all 6HP26A61(2) **except vehicles with Audi W12-engine**
all 6HP28, 6HP28X, 6HP28A61,
all 6HP32, 6HP32A (2), 6HP32X

LifeguardFluid6+ S671 090 281

6HP26A61(2) **for vehicles with Audi W12-engine**

LifeguardFluid8 AA00 601 304

all 6HP19A (2)
6HP19X **for Audi Q7**
all 6HP28AF (2)

(2) differential require different oil, see TE-ML11 for specifications.

Transmissions fluid level checking.

- The transmission fluid temperature must be between 30°C and 35°C before checking can begin. Use test equipment to determine the trans temperature.
- The vehicle must be level with engine running at idle speed and air conditioning turned on.
- Step on the brakes firmly, apply parking brake fully and shift to D and R, briefly pausing in each position before shifting back to the Park position.
- With the engine running at idle speed and the selector in Park position, remove the filler plug. Monitor the transmission temperature, if a small stream of oil runs out at 40°C, the fluid level is correct.
- If no oil runs out when the filler plug is removed, the fluid level is too low and oil needs to be added until it overflows.
- With engine running, install the oil filler plug and tighten to proper torque.

Adding fluid after repairs.

- With the engine stopped and the transmission in Park position, remove the oil filler plug. Add transmission fluid until a small stream of oil runs out.
- Insert the filler plug and tighten by hand. Start the engine.
- With the engine running, remove the oil filler plug and add transmission fluid until a small stream of oil runs out. Insert the filler plug and tighten by hand.
- Follow the “Transmission fluid level checking” procedure described in section **Transmission fluid level checking** above.

Mechatronic Replacement Hints

Fluid level procedures

Notes on fluid level and adding procedure.

- Use only ZF-LifeguardFluid6 or OE approved transmission fluid.
- If the transmission temperature rises above 50°C during the fluid level checking procedure the resulting oil level will be too low. Let the transmission cool down and repeat the fluid level procedure.
- Have transmission fluid and a suitable oil pump available before starting the fluid level procedure. The transmission fluid temperature will rise quickly during the checking procedure.

Mechatronic Replacement Hints

Drain and filler plug location for 6HP19/21 with plastic oil pan

The CTSC
the california transmission
supply company, LLC

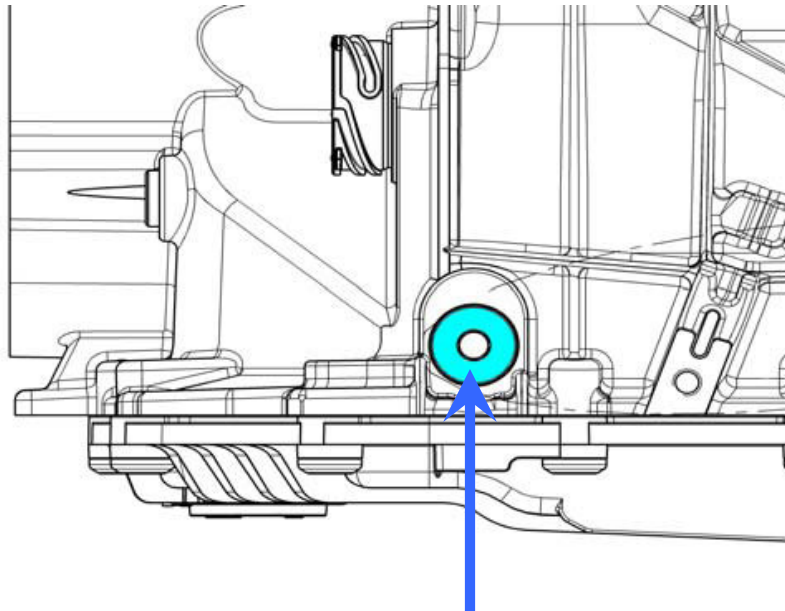

Filler plug **M18x1.5**
Inner hexagon **8mm**
Tightening torque **35 Nm ± 3.5 Nm**

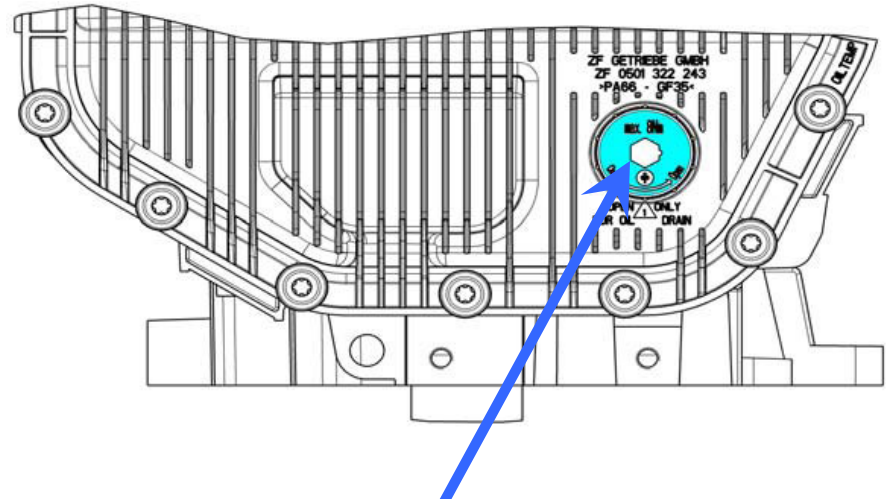

Drain plug **M24x1**
Inner hexagon **10mm**
Tightening torque **8 Nm - 0.5 Nm**

Mechatronic Replacement Hints

Drain and filler plug location for 6HP19X/21X with plastic oil pan

The CTSC
the california transmission
supply company, LLC

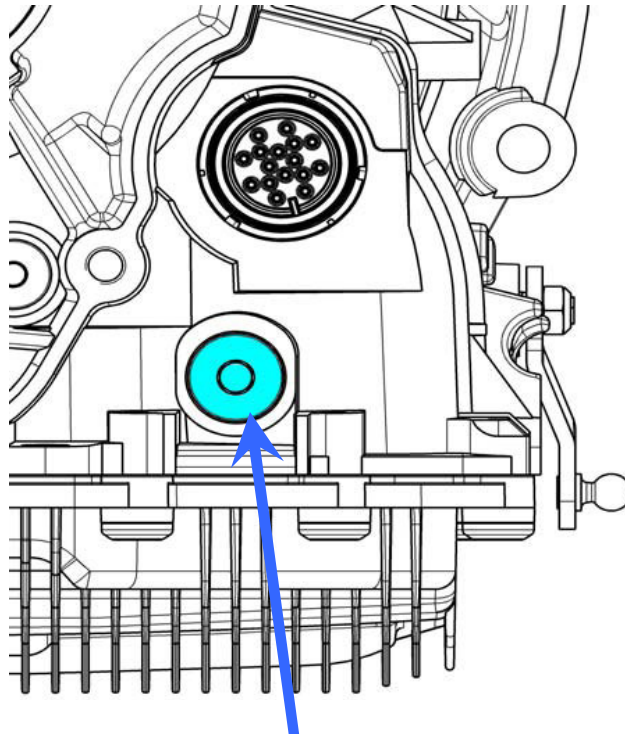

Filler plug **M18x1.5**
Inner hexagon **8mm**
Tightening torque **35 Nm ± 3.5 Nm**

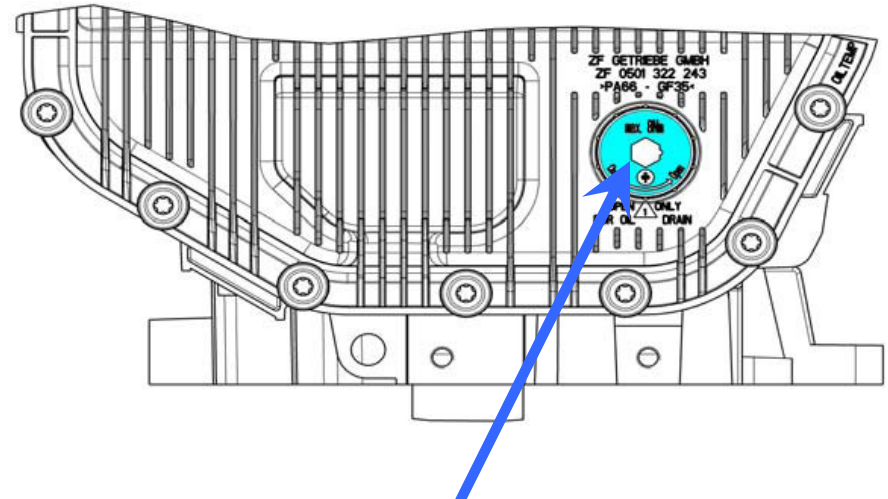

Drain plug **M24x1**
Inner hexagon **10mm**
Tightening torque **8 Nm - 0.5 Nm**

Mechatronic Replacement Hints

Drain and filler plug location for 6HP26/28/32 with plastic oil pan

The CTSC
the california transmission
supply company, LLC

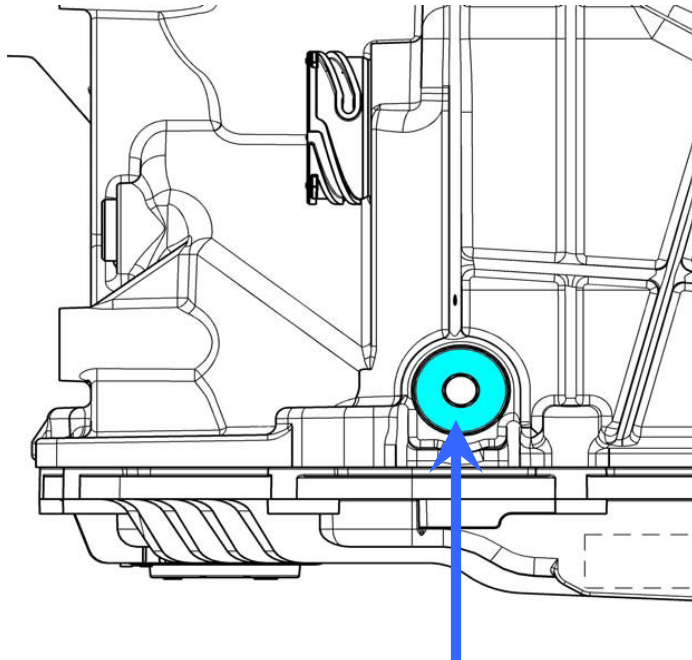

Filler plug **M18x1.5**
Inner hexagon **8mm**
Tightening torque **35 Nm ± 3.5 Nm**

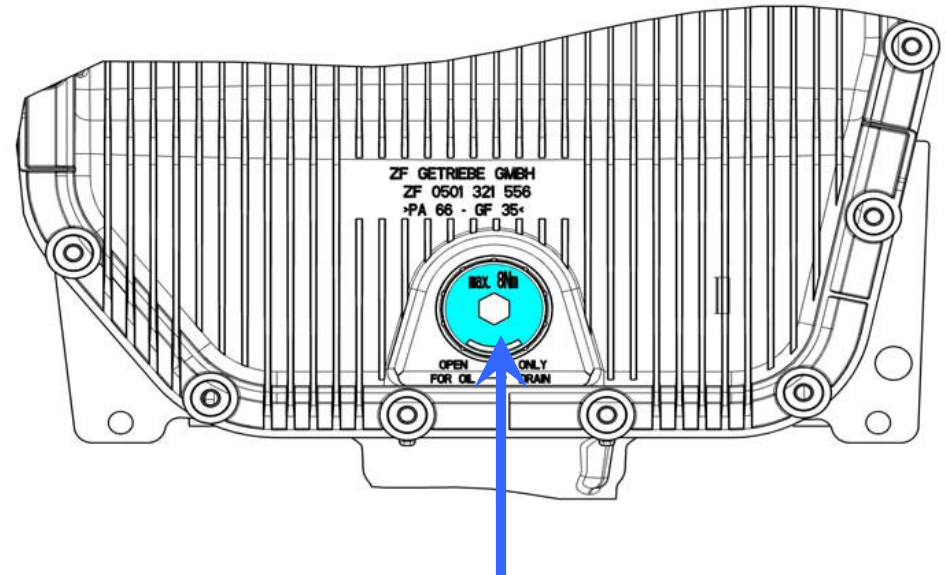

Drain plug **M24x1**
Inner hexagon **10mm**
Tightening torque **8 Nm - 0.5 Nm**

Mechatronic Replacement Hints

Drain and filler plug location for 6HP26X with steel oil pan

The CTSC
the california transmission
supply company, LLC

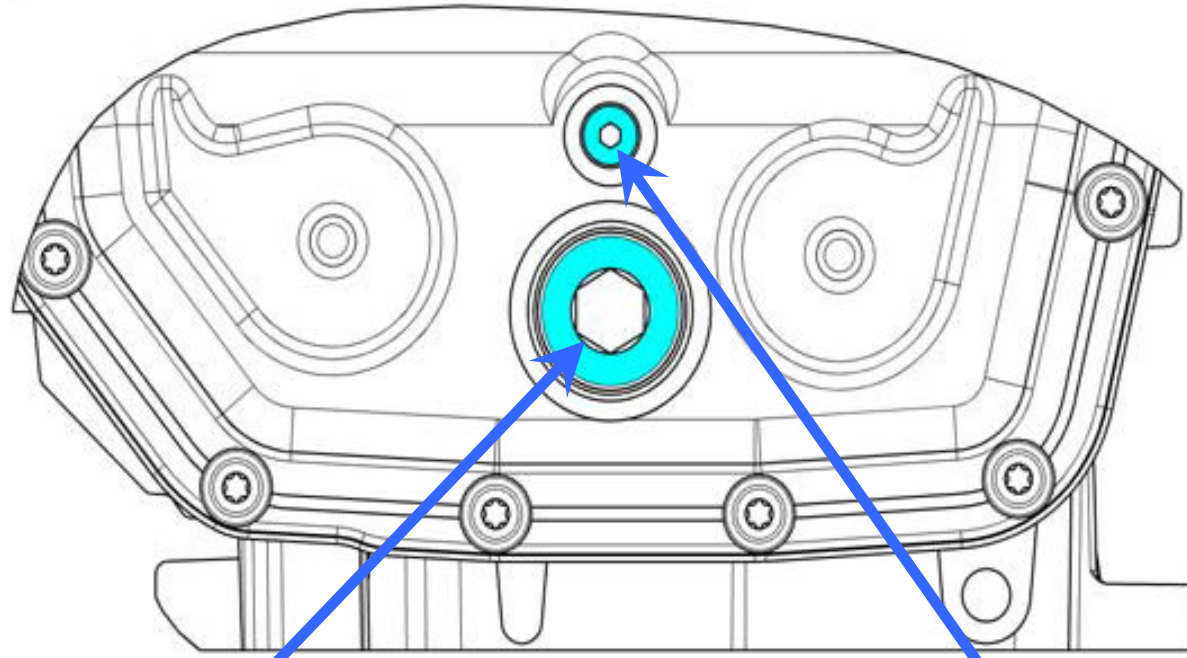

Filler plug **M30x1.5**
Inner hexagon **17mm**
Tightening torque **80 Nm ± 8 Nm**

Drain plug **M10x1**
Inner hexagon **5mm**
Tightening torque **12 Nm ± 1.2 Nm**

Mechatronic Replacement Hints

Core Return

- Insert the old sealing sleeve back into the mechatronic, push the locking tab into its locked position for core return shipping.

Note

- Avoid touching any electrical pins to prevent ESD (electrostatic discharge) damage.

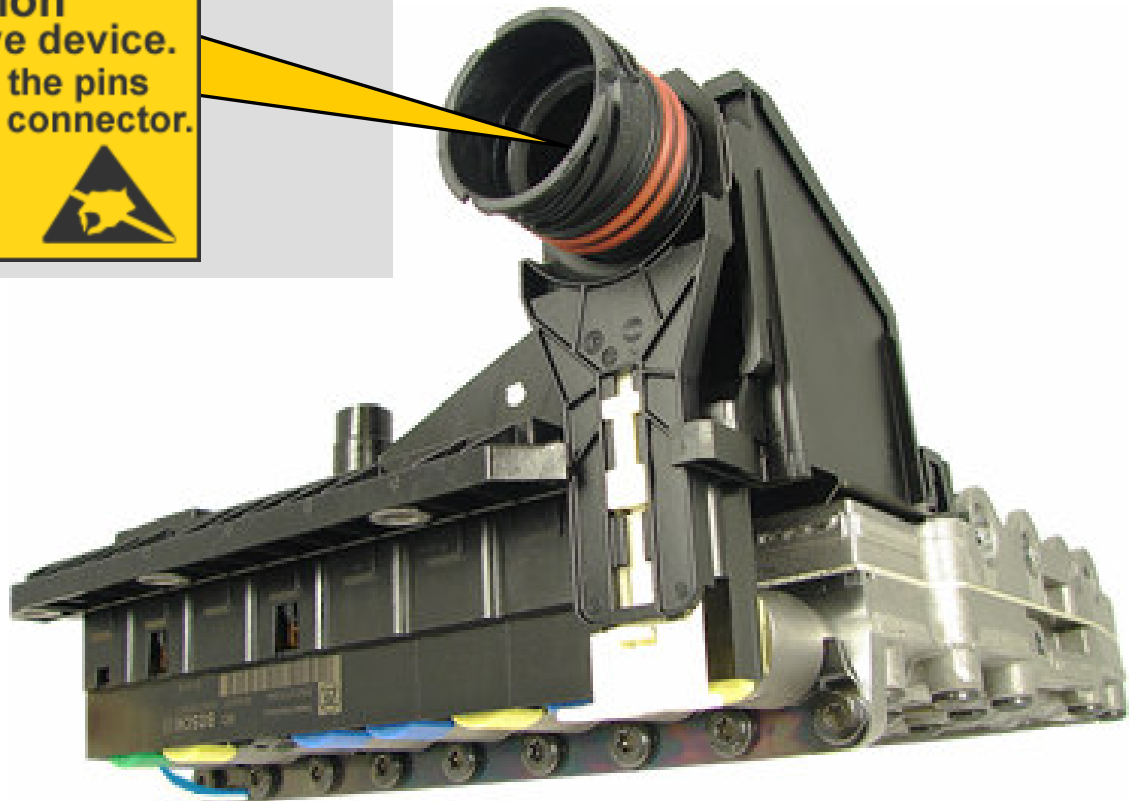

Mechatronic Replacement Hints

Core Return

- To receive full credit core unit must be returned undamaged.
Packaging recommendation:



- Use the original shipping box for the mechatronic return.
Place the cardboard insert upside down into the shipping box.



- Add additional packaging material to the bottom of the box.

Mechatronic Replacement Hints

Core Return

- To receive full credit core unit must be returned in the original box..
Packaging recommendation:



- Place the mechatronic into a plastic bag to prevent oil leakage, then set into shipping box.
Note: Clean up charges due to leaking packages will be deducted from the core credit..

Note

- Do not return the oil pan or any of the sealing parts that came with the mechatronic.



- Add additional packaging material on top of the mechatronic to provide a snug fit in the shipping box.

Note

- Package mechatronic as secure as possible, damage to the mechatronic will result in deduction or loss of your core credit.

No Communication - Failsafe

Most common issues after mechatronic replacement

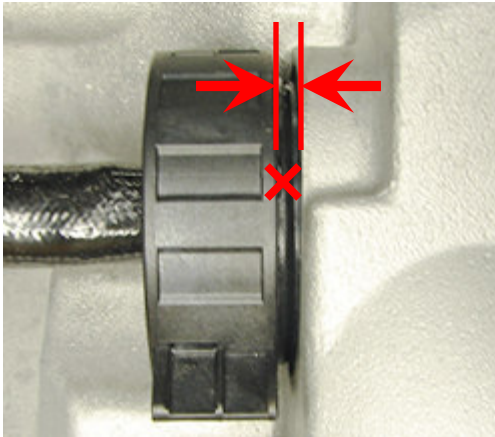

CHECK GAP BETWEEN HOUSING AND CONNECTOR

IS THE GAP X LARGER THAN 3.0mm?

YES

NO

THE SLEEVE IS NOT PROPERLY SEATED IN THE MECHATRONIC. REINSTALL PROPERLY.

CHECK FOR PUSHED BACK PINS AT THE VEHICLE CONNECTOR?

PINS PUSHED BACK?

YES

NO

REPAIR AS NECESSARY

ARE YOU ABLE TO ACCESS ALL OTHER SYSTEMS?

YES

NO

TROUBLESHOOT COMMUNICATION PATH

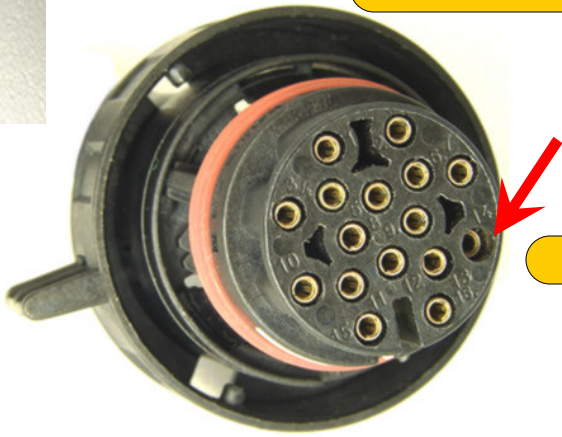

WITH VEHICLE CONNECTOR DISCONNECTED AND IGNITION ON, CHECK VOLTAGE AS FOLLOWS

PIN 13 to PIN 14 – RECORD VOLTAGE
PIN 13 TO PIN 9 – RECORD VOLTAGE
PIN 16 TO PIN 14 – RECORD VOLTAGE
PIN 16 TO PIN 9 – RECORD VOLTAGE

IS VOLTAGE BETWEEN PINS BATTERY VOLTAGE?

YES

NO

RECOMMEND MECHATRONIC REPLACEMENT

TROUBLESHOOT POWER PATH - FUSES

