



This Service Information bulletin supersedes SI B24 08 06 **dated March 2010**.

**NEW** designates changes to this revision

## SUBJECT

**NEW**

### ZF 6HP Transmissions - Mechatronic Sealing Sleeve Seepage

#### MODEL

**NEW** E53, E60, E61, E63, E64, E65, E66, E85, E90, E91, E92, and E93 vehicles with ZF 6-speed 6HP19/21 or 6HP26/28 transmissions produced up to 04/08

#### **NEW** SITUATION

Transmission fluid seepage is visible in the area of the transmission oil pan. In most cases, only an oil "wetness" spot is spotted in the back of the transmission oil pan (the transmission fluid does not drop on the ground).

#### **NEW** CAUSE

The Mechatronic sealing sleeve's O-ring tightness

#### PROCEDURE

**NEW** 1. Only if a visible leakage trace indicates a substantial loss of transmission fluid (e.g., transmission fluid accumulation on the underbody panel), replace the Mechatronic sealing sleeve.

**NEW** The "oil wetness" in the area of the sealing sleeve is not an indication of substantial leak, and does not justify this repair.

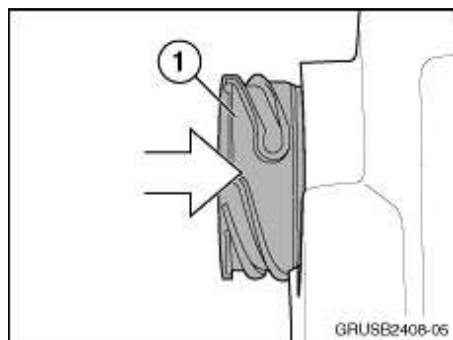

**NEW** 2. Drain and save the long-term fill transmission fluid (Shell M-1375.4).

Replace the sealing sleeve (P/N 24 34 7 588 725) and the transmission oil pan gasket. Follow Repair Instruction REP 24 34 020.

**Note:** It is not necessary to replace the transmission oil pan bolts set during this repair. Unnecessary pan bolts replacement will be debited.

#### **Important:**

Make sure to push the sealing sleeve firmly into the housing assembly before closing the white locking tab of the Mechatronic.

To ease the sleeve installation, use some lubrication (e.g., transmission fluid) on both sleeves' O-rings.

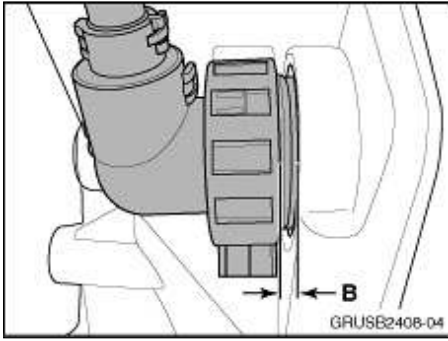

3. After installation, the correct distance between the transmission harness connector and the housing surface (B) should not exceed 3 mm.

**Important:**

When installing the transmission harness connector, do not use excessive force - locking of the connector should not require an increased effort. This would be an indication of an incorrectly installed sealing sleeve!!!

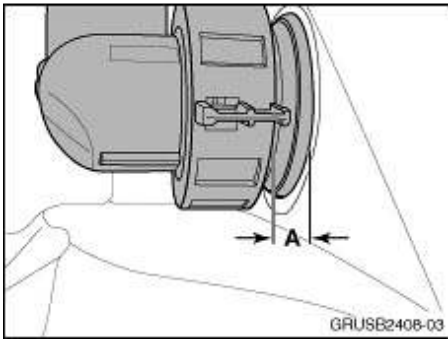

**NEW** 4. If the distance between the connector and the transmission housing (A) measures approximately 7 to 8 mm, the sealing sleeve was installed incorrectly. In such a case, an intermittent connection problem between Mechatronic and the vehicle harness connector will occur, resulting in various EGS communication faults (e.g., FC 5079 "Serial wire message missing"; FC 507A "Serial line signal plausibility"; "Gearbox Emergency Program" lamp illumination; and the transmission entering a failsafe mode).

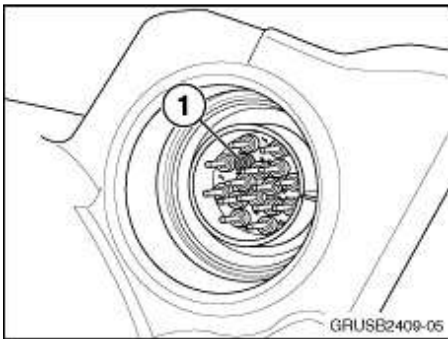

5. In some cases, the incorrectly installed sealing sleeve may permanently damage pins in the Mechatronic connector (X8500). In such a case, the Mechatronic module has to be replaced (**pin repair is not possible**). The illustration shows an example of a broken and missing pin #4 in the X8500, caused by improper sleeve installation; this resulted in the customer's complaint about the inoperative Sport Mode of the transmission.

**IMPORTANT:**

Damage to the Mechatronic connector (X8500) pins, caused by an improper installation on the sealing sleeve and a subsequent Mechatronic replacement, **is not covered under the BMW warranties**.

6. Clean the groove in the plastic oil pan before gasket installation. When reinstalling the oil pan, make sure that the sealing surface of the gasket is oil-free.

**Important:** If the sealing surface is not completely dry, the oil pan may still appear to exhibit a minor leak. Follow the torque sequence and specification from REP 24 34 020.

7. On vehicles equipped with a plastic oil pan (all with the exception of the E53), replace the drain plug. Follow the torque specification from REP 24 34 020.

**NEW** 8. IMPORTANT NOTE:

It is not necessary to replace the transmission oil pan during this repair. Unnecessary oil pan replacements warranty claims will be debited.

**NEW** 9. Check and top up the transmission fluid level using Shell M-1375.4. For the filling procedure, refer to

REP 00 11 500.

**NEW Note:**

Up to 1 liter of Shell M-1375.4 transmission fluid can be claimed for topping up the transmission fluid level.

10. Warm the engine and test drive the vehicle to verify the effectiveness of the repair.

**PARTS INFORMATION**

<b>Part Number</b>	<b>Description</b>	<b>Quantity</b>
24 34 7 588 725	Mechatronic sealing sleeve	1
24 11 7 571 204	<b>NEW</b> 6HP26/28 - oil pan gasket for E60/61/63/64/65/66 vehicles equipped with eight cylinder engine (N62/N62TU)	1
24 11 7 543 484	6HP26 - oil pan gasket for E53 equipped with eight cylinder engine (N62) – X5 4.4i	1
24 11 7 571 235	<b>NEW</b> 6HP19/21 - oil pan gasket all models equipped with six cylinder (M54/N52/N52K/N54)	1
24 11 7 520 713	Drain plug 6HP19/6HP26 (except E53)	1
<b>NEW</b> 83 22 0 406 929	Topping up fluid level with up to 1 liter of Shell M-1375.4	2

**NEW WARRANTY INFORMATION**

Covered under the terms of the BMW New Vehicle Limited Warranty or the BMW Certified Pre-Owned Program.

Please refer to the latest KSD for model applicable labor allowances.

**Defect Code**            **24 00 51 48 00**

**Main Work\***

Labor Operation	24 34 020*	Replace sealing sleeve for gearbox <b>Vehicles with 6HP26/28 transmission</b>
	24 34 021*	Replace sealing sleeve for gearbox <b>Vehicles with 6H19/21 transmission</b>

\*Main Work: Use this labor operation number when this is the only repair being performed, or if this is the main repair when performed along with other repairs at the same time. If this is not the main repair, use the associated (+) labor operation code.