

E60 - Head-up display

Installation location

The head-up display is installed above the steering column in the instrument panel.

Construction

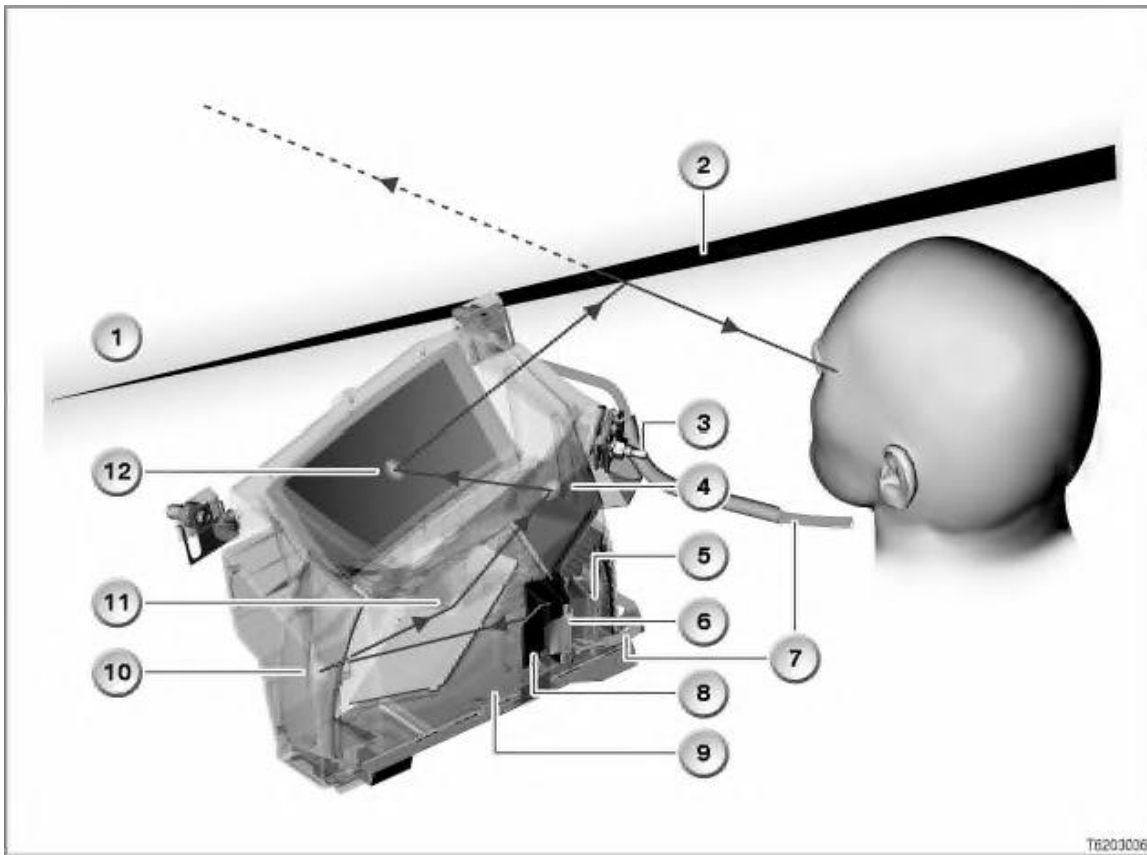

Key	Explanation	Key	Explanation
1	Windscreen	2	Wedge-shaped plastic film between the inner and outer glass of the windscreen
3	Adjusting screw for height adjustment within the defined eye position range	4	Mirror with flat surface
5	Light source	6	Projection display
7	from 12/2003 Flexible shaft, connected to projection display	8	Projection display cover panel
9	Casing	10	Curved mirror
11	Curved mirror	12	Curved mirror

The key components of the head-up display are:

- 4 mirrors

The 4 mirrors ensure that the contents of the projection display appear at the distance and in the size required, and that deformations caused by the windscreen are largely compensated for.

- Light source

The light source is the back lighting of the projection display. This light source is a number of coloured LEDs laid out in rows over a certain area.

The light source is actuated by the electronic circuitry in the head-up display, which also controls the brightness of the display content.

- Projection display with cover panel

The projection display with TFT technology (TFT = thin-film transistor) is used to show the display contents. The projection display is activated by the electronic circuitry of the head-up display.

A cover panel protects the projection display when it is switched off. When the projection display is switched on, the cover panel helps to heat the projection display more quickly. Up to a certain temperature, the projection display cover panel remains closed. A stepper motor folds the cover panel out of or into the beam. The stepper motor is actuated by the electronic circuitry in the head-up display.

- Electronic circuitry

The electronic circuitry has the following tasks:

- Actuation of light source and of stepper motor for cover panel
The electronic circuitry includes a temperature sensor whose signal is evaluated for the actuation of the stepper motor. At the same time, the temperature sensor protects the head-up display from overheating. The light source is switched off if the temperature exceeds approx. 105 °C.
- Evaluating and processing incoming image information
- Generating display content

A power supply in the head-up display provides the light source with a voltage of 42 volts, transformed from the on-board supply voltage.

A 12-pin connector on the head-up display creates the connection to the vehicle electrical system. The MOST data bus is connected to the head-up display via a 2-pin connector.

Pin assignment X13819, 12-pin

Pin	Type	Description
1	E	Signal wire from button for switching head-up display on and off
2	---	---
3	E/A	K-CAN High
4	E/A	K-CAN Low
5	V	Terminal 30g (power supply, active)
6	V	Terminal 30g (power supply, active)
7	A	Negative wire to button for switching head-up display on and off
8	---	
9	---	
10	---	
11	M	Terminal 31 (earth)
12	M	Terminal 31 (earth)

E = Input
 E/A = Input and output
 M = Earth
 V = Supply

For current specifications regarding pin assignment, please refer to BMW diagnosis system

Pin assignment X13835, 2-pin

Pin	Type	Description
1	E	MOST data bus input
2	A	MOST data bus output
E = Input A = Output		For current specifications regarding pin assignment, please refer to BMW diagnosis system

How it works

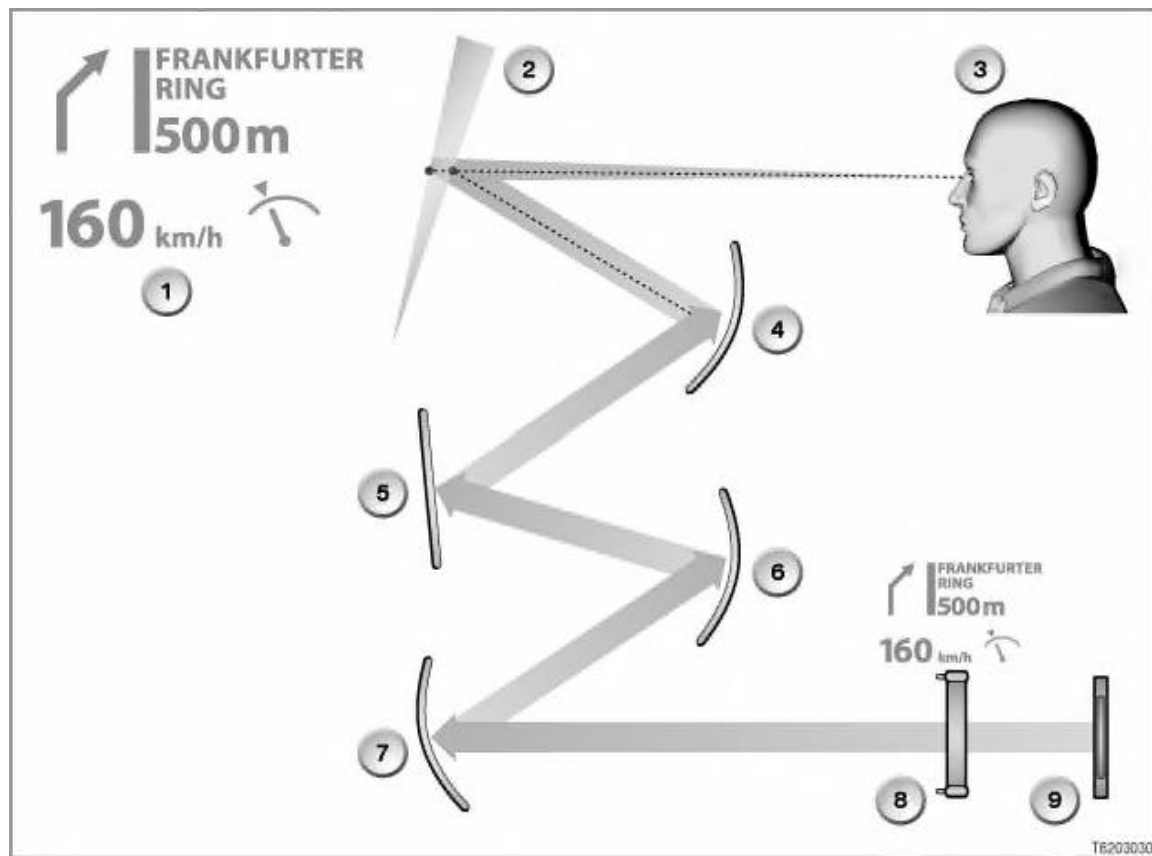

Key	Explanation	Key	Explanation
1	Virtual image	2	Display content is projected onto the windscreen
3	Observer's viewpoint	4	Curved mirror
5	Flat mirror	6	Curved mirror
7	Curved mirror	8	Projection display
9	Light source		

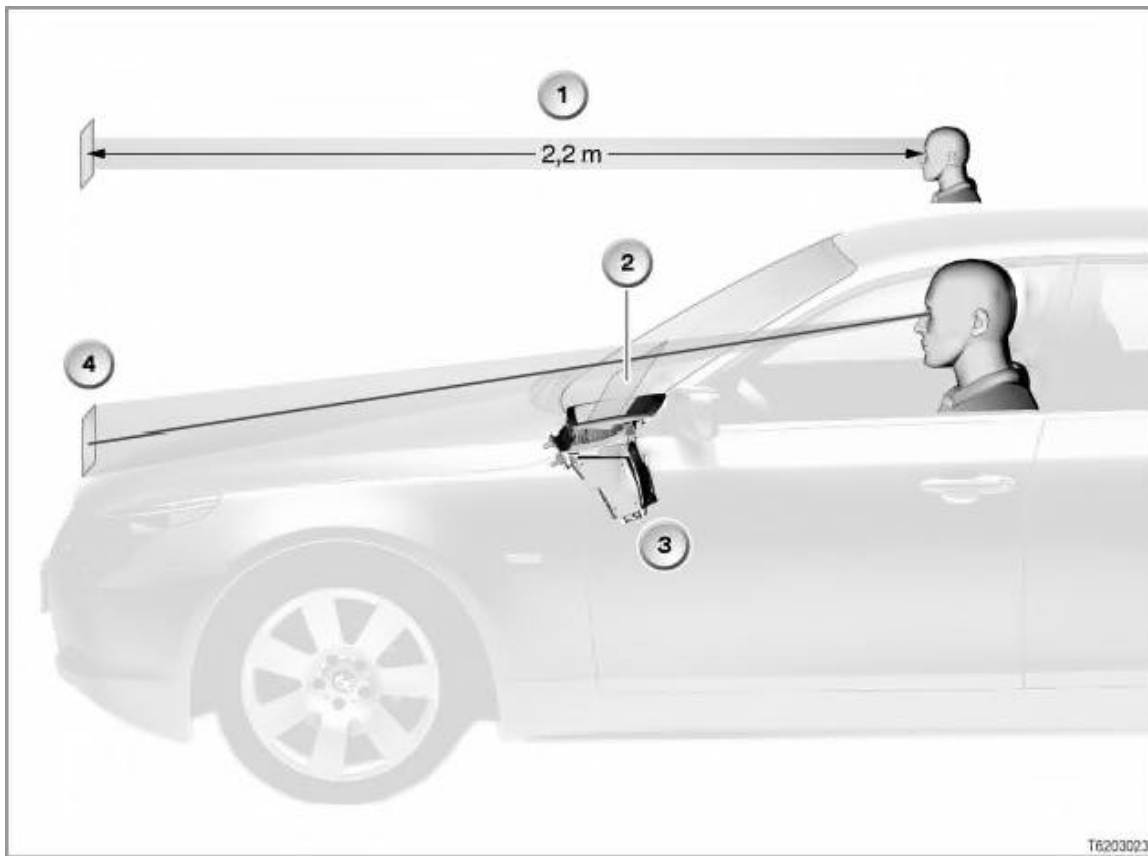

Key	Explanation	Key	Explanation
1	Distance from observer's viewpoint to virtual image	2	Projected image on windscreen
3	Head-up display	4	Virtual image

The virtual image appears to float in the air at the end of the bonnet, approx. 2.2 metres away from the observer. The size of the virtual image is approx. 20 x 10 cm (width x height).