Table of Contents

E90 Voltage Supply & Bus Systems

Subject	Page
Vehicle Electrical System	4
Introduction	4
Battery Connections	5
Rear Power Distribution	6
Battery Safety Terminal	7
Intelligent Battery Sensor (IBS)	8
IBS Measuring /Evaluation Function	10
Servicing the IBS	11
IBS Diagnosis	11
Voltage Measurement	11
Current Measurement	11
Terminal 15 Wake-up Signal Faults	12
IBS Wake-up	12
Vehicle Ground Points	13
Junction Box	16
Distribution Box	16
Junction Box Electronic Control Module (JBE)	19
Bus Systems	22
K-Bus	26
K-Bus (protocol)	26
LIN-Bus	26
BSD	26
Terminating Resistors	26
MOST Bus	27
Light Direction	28
Fiber Optics Connector	29
Identification of Fiber Optics Conductors	29
Diagnosis Information	30
Data Flow Interruption	30
Overtemperature Shut-Down	30
Power Management	33
Power Consumption During Operation	34
Idle Speed Boost	34

Subject	Page
Electric Load Reduction - Engine Running34
Electric Load Cut-Off with Engine Off35
Terminal 30g Relay (Time-Dependent Deactivation)36
Terminal 30g_f Relay (Fault-Dependent Deactivation)37
Terminal 30 (KL30)39
Terminal 15 (KL15)40
System Diagnosis Information41
Closed Circuit Current42
Transport Mode43

Voltage Supply & Bus Systems

Model: E90

Production: From Start of Production

OBJECTIVES

After completion of this module you will be able to:

- Understand the power distribution function
- Explain the Power Management function
- Diagnose current draw situations
- Identify importance of Junction Box
- Understand the vehicles bus structure

Vehicle Electrical System

Introduction

The voltage supply system on the E90 uses a Junction Box (JB) with a control module as a primary power distribution point and bus system gateway. To ensure balanced energy management in the vehicle an energy management function similar to that used in the E60 is utilized and is incorporated into the operating software of the DME.

The power supply system in the E90 consists of the following:

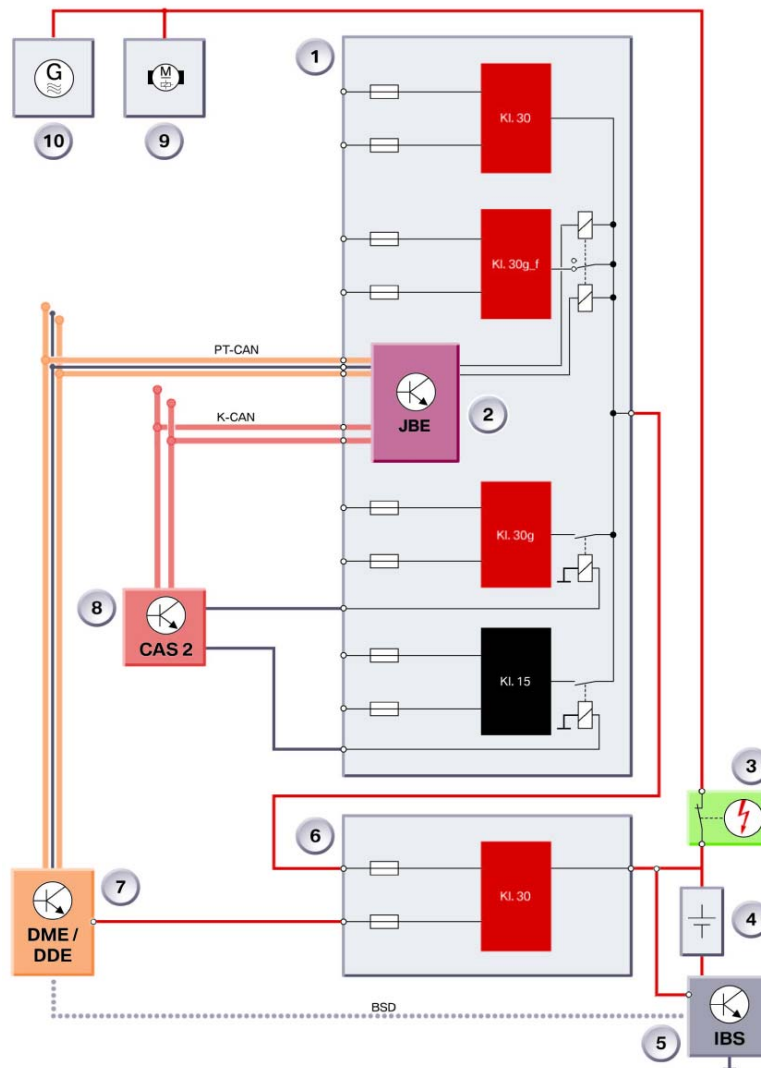

Index	Explanation	Index	Explanation
1	Junction Box & Terminal 30 Relays	6	Rear Power Distribution Box
2	Junction Box Electronics Control Module	7	DME
3	Safety Battery Terminal	8	CAS
4	Battery, Cables & Grounds	9	Starter
5	Intelligent Battery Sensor (IBS)	10	Alternator

Battery Connections

Located on the right side of the luggage compartment is the battery, from here power is supplied to the starter, alternator, engine electronics and to the junction box by way of three main supply cables.



1. One main cable is routed on the interior of the vehicle along the right side, to the junction box located behind the glovebox.
2. Two additional main cables run from the B+ terminal underneath the vehicle to the engine compartment:

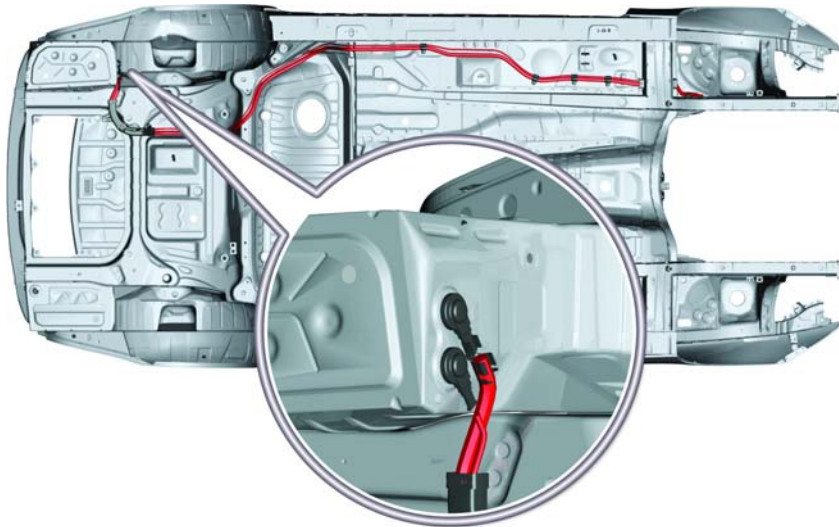

Within the battery box are two transfer points (as shown) for the two cables that run to the engine compartment.

The main power cables going to the engine compartment are installed/routed (as indicated) in a protected area underneath the body of the vehicle.

- One cable goes to the jump start terminal in the engine compartment and then connects to the starter and alternator.
- The second cable is used to supply power to the engine electronics (DME and Valvetronics).

Rear Power Distribution

Attached directly to the top of the battery is the rear power distribution box which contains the fusible links (non replaceable) used to distribute power to the Junction Box and Engine Electronics, plus supply power to the Intelligent Battery Sensor (IBS).

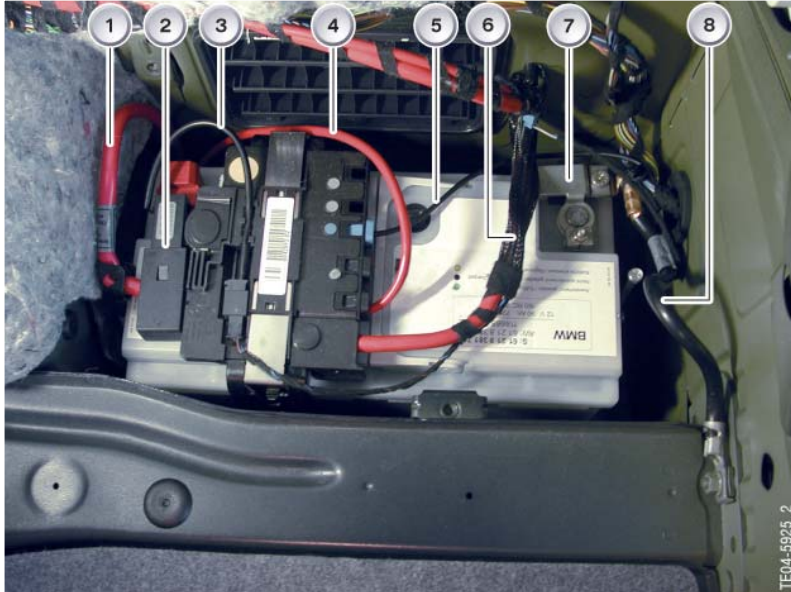

Index	Explanation
1	B+ to Starter & Alternator
2	Battery Safety Terminal (BST)
3	Connection from MRS to BST
4	B+ to Engine Electronics
5	B+ for IBS Electronics
6	B+ to Junction Box
7	Intelligent Battery Sensor (IBS)
8	Battery Ground

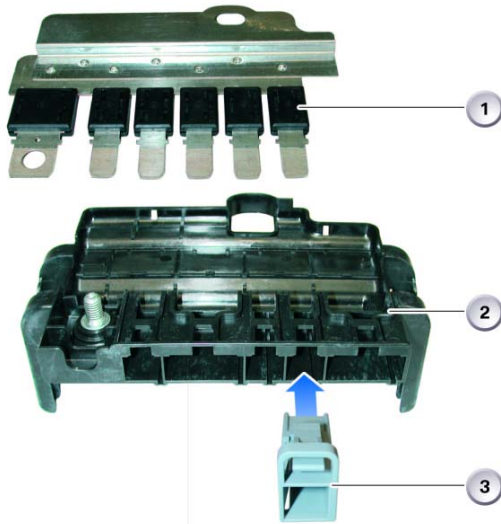

Index	Explanation
1	Fuses
2	Rear Power Dist. Box Housing
3	Connectors - High Current

Note: The rear power distribution box is only replaceable as a complete unit. The fuses can not be replaced.

Battery Cables	Cross Section	Material
Line to Starter and Alternator	80 mm ²	Aluminum
Line to the Junction Box	40 mm ²	Copper
Line to the Engine Electronics	10 mm ²	Copper

Battery Safety Terminal

The Battery Safety Terminal (BST) is used to reduce the risk of a short circuit to the B+ terminal of the battery in the event of an accident, as a result of a short circuit on the cable running from the B+ terminal of the battery to the Starter & Alternator (an unfused/unprotected circuit) .

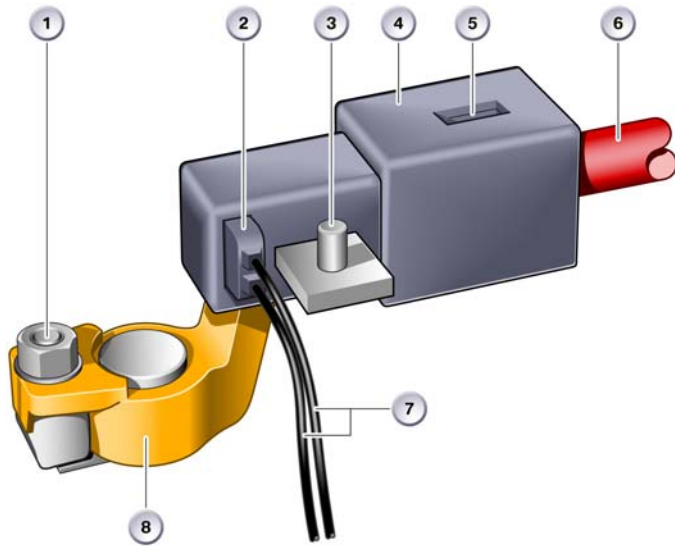

Index	Explanation
1	B+ to Starter & Alternator
2	BST Igniter Connection
3	B+ To Rear Power Distribution
4	BST Plastic Housing
5	BST Retaining Spring Clip
6	B+ to Starter & Alternator
7	BST Igniter Signal from MRS
8	B+ Positive Battery Terminal

Depending on the severity of an accident incurred, the MRS control module will provide a signal to the BST which will disconnect the B+ cable going to the Starter & Alternator. In the event that the BST is activated, power will continue to be supplied to the rear power distribution box (a fused/protected power distributor) to allow activation of all other vehicle systems (such as hazard lights, power locks, power windows, Engine Electronics etc.).

Note: Refer to “ST403 Passive Safety Systems” for more detailed information on BST operation.

Intelligent Battery Sensor (IBS)

The Intelligent Battery Sensor (IBS) as a mechanical/electronic device which is connected directly to the negative battery terminal.

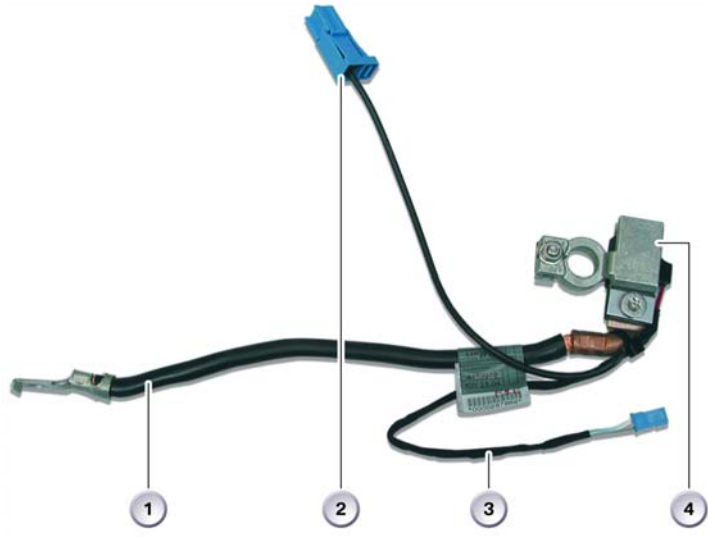

Index	Explanation
1	Battery Ground Lead
2	B+ Connection for IBS
3	Bit Serial Data Interface (BSD)
4	Intelligent Battery Sensor (IBS)

The IBS contains a micro processor that is used to monitor/measure various battery conditions such as:

- Terminal voltage via measurement from B+ to Gnd
- Charge/discharge current via integrated shunt resistor
- Temperature of battery acid via integrated temp sensor

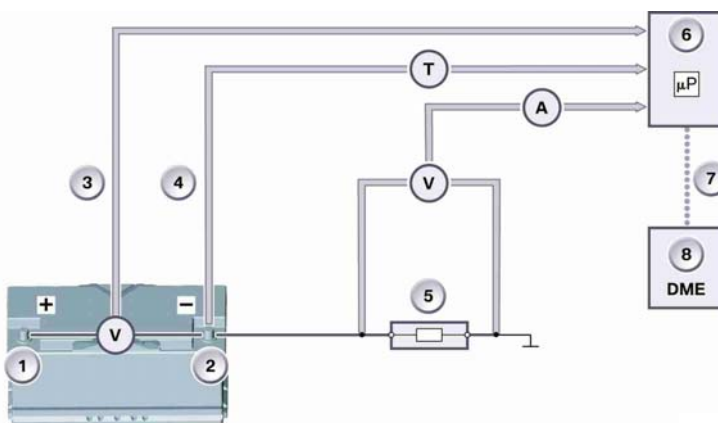

Index	Explanation
1	B+
2	B-
3	Battery Voltage Measurement
4	Battery Temp Measurement
5	Current Measurement
6	Microprocessor
7	BSD
8	DME/ECM

The IBS is able to withstand thermal loads up to 105°C, the chemical effects of the battery acid.

The components of the IBS are shown below:

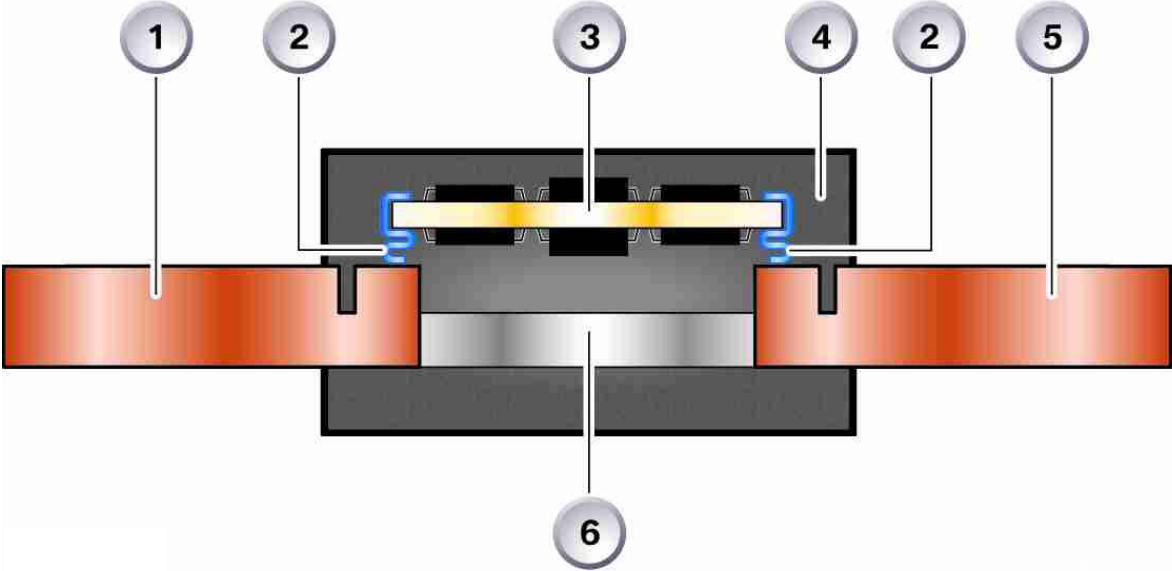

Index	Explanation	Index	Explanation
1	Copper	4	Injection Molding/Housing
2	Gullwings/Tabs	5	Copper
3	PC Board with Evaluation Electronics	6	*Manganin

***Manganin - Is a copper alloy resistor with a low resistance value, that is able to maintain an extremely constant temperature regardless of current flow. This material is used as a shunt resistor to measure current flow by the evaluation electronics component of the IBS.**

■ IBS Measuring /Evaluation Function

The measuring/evaluation function of the IBS electronics, continuously measures the following values under all vehicle operating conditions:

- Voltage (6 V to 16.5 V)
- Current (200 A to +200 A)
- Closed Circuit Current (0 A to 10 A)
- Starting Current (0 A to 1000 A)
- Temperature (-40°C to 105°C)

When the vehicle is stationary, the IBS is programmed to wake up every 14 sec. and makes the required measurements within approx. 50 ms in order to save power.

The measured values from the IBS are provided to the DME by way of the Binary Serial Data Interface (BSD) to calculate the State of Charge and State of Health for the battery.

- State of Charge (SoC) is a calculated condition showing the current charge of the battery. SoC is used during key “OFF” periods to insure the battery maintains a sufficient charge to start the engine at least one more time.
- State of Health (SoH) tracks the history of the battery in the vehicle. Charge/discharge cycles and times are monitored. SoH helps the DME determine the proper charging rates and anticipated battery life. Internal resistance of the battery is calculated by the IBS from the current and voltage dip during engine start. The values are forwarded to the DME to calculate the SoH of the battery.

Software contained in the microprocessor of the IBS utilizes the measured values to calculate the State of Charge (SoC) of the battery during vehicle sleep mode and compares this information with that received from the DME/ECM pertaining to the battery SoC/SoH, during the period of time between engine “OFF” and deactivation of the DME main relay.

The current SoC/battery data is stored in the IBS every 2 hours over a 6 hour time frame, providing 3 - 2 hour snapshots of battery SoC information. The stored information/snapshot data is overwritten every 6 hours. Whenever KL15 is activated the IBS updates the DME with the current closed circuit histogram/battery status information, byway of the BSD. Upon obtaining updated information the DME evaluates the new data and if a closed-circuit current draw is identified a fault will be stored in the fault memory of the DME.

■ Servicing the IBS

The IBS is very sensitive to mechanical stress and strain. It is serviced as a complete unit with the ground cable. The ground cable also serves as a heat dissipater for the IBS.

Particular attention should be paid to the following points in service:

- Do not make any additional connections at the negative terminal of the battery
- Do not modify the ground cable
- Do not make any connections between the IBS and the sensor screw
- Do not use force when disconnecting the ground terminal from the battery
- Do not pull at the ground cable
- Do not use the IBS as a pivot point to lever off the ground terminal
- Do not use the connections of the IBS as a lever
- Use only a torque wrench as described in the repair manual
- Do not release or tighten the sensor screw

■ IBS Diagnosis

A fault code is stored in the DME when the IBS is defective. The DME adopts a substitute value and assumes IBS emergency mode. IBS emergency mode boosts the idle speed in order to sufficiently charge the battery.

Direct diagnosis of the IBS is not possible, it can only be diagnosed through the DME. The self diagnosis function checks the voltage, current, temperature, terminal 15 wake up signal as well as system errors in the IBS.

Note: The software in the DME and that of the IBS must match. To ensure this requirement it may be necessary to replace the IBS in connection with a software update.

■ Voltage Measurement

If the IBS is shorted to ground, a DME fault code will display “Voltage Fault DME ON”. The IBS will be unable to wake up the DME.

If the IBS is shorted to B+, a DME fault code will display “Voltage fault, DME not ON” and no charging current. The vehicle will NOT enter sleep mode.

■ Current Measurement

Current measurement is a very dynamic process, indicated by the measuring range of mA to kA.

The fault code “Current Fault” is entered in fault memory when an implausible value is determined during the plausibility check of the various measuring ranges of the IBS.

Terminal 15 Wake-up Signal Faults

The IBS recognizes wake-up line faults. The IBS can detect a wake-up line error under the following conditions:

- DME "ON"
- Terminal 15 "ON" (voltage high at IBS)
- Terminal 15 running via BSD

If Terminal 15 at the IBS and Terminal 15 via the BSD are not equal, a fault is indicated in the BSD line or an IBS Fault.

IBS Wake-up

The IBS constantly monitors the SoC, even when the vehicle is asleep, a wake-up signal is sent to the DME via the BSD if the SoC falls below the preset threshold. Upon obtaining the wake-up from the IBS, the DME obtains information on the current SoC of the battery from the IBS and requests that auxiliary electrical loads be switched off.

The IBS may only wake-up the vehicle once during a key off cycle, once awakened the vehicle will again return to the sleep mode.

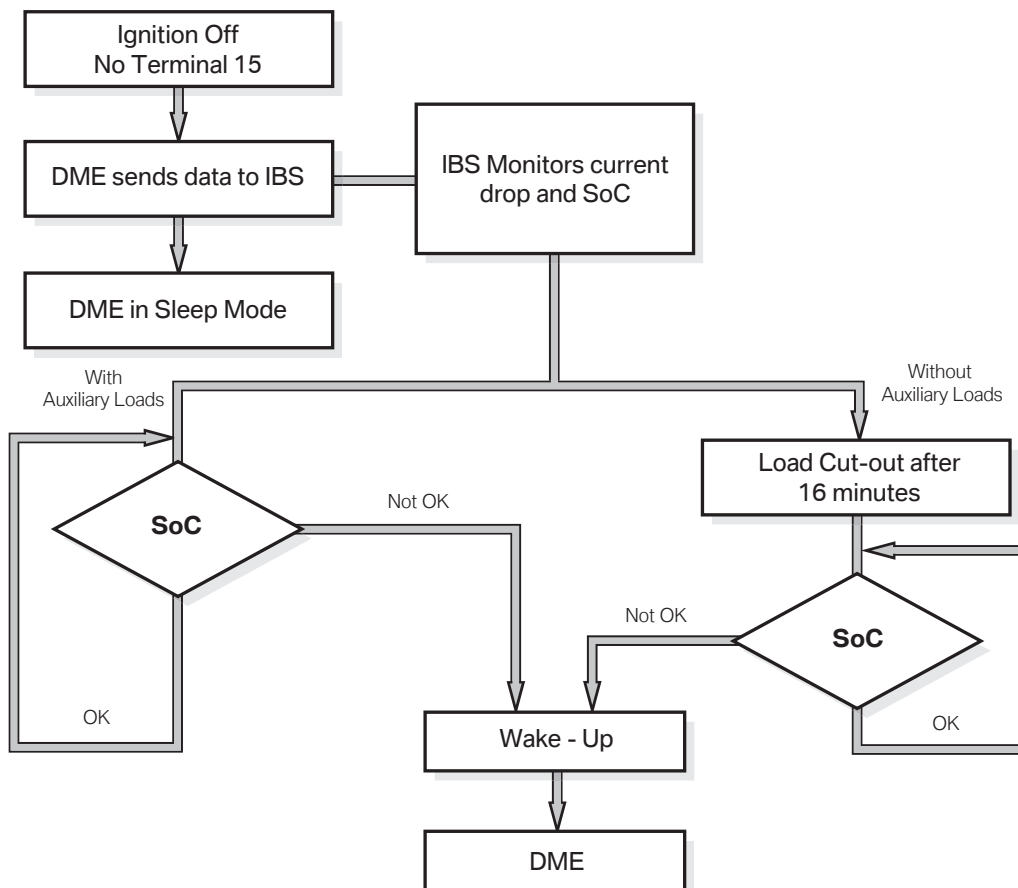

Vehicle Ground Points





Classroom Exercise - Review Questions

1. What components make up the rear power distribution?

2. What information is recorded by the IBS?

3. Information from the IBS is transmitted to where? Via what path?

4. Why does the IBS send a wake-up signal? What module wakes up?

5. What function does the IBS provide?

NOTES

PAGE

Junction Box

On the 3 series (E90) the Junction Box (JB) plays a central role in the distribution of power to the various components installed in the vehicle. Based on the equipment level installed in a vehicle the JB may be “configured” differently. For us vehicles only one variant will be available.

Contained in the Junction Box is a:

- Distribution box/fuse carrier
- Electronic control module



Distribution Box

Depending on the equipment level installed in the vehicle, the configuration of the PC board installed in the distribution box will vary. Different relays and/or resistors can be soldered to the board depending on the systems installed on the vehicle.

Integrated into the Junction Box is a PC board which contains soldered on relays for:

- Wiper stage 2
- Horn
- Terminal 30g_f
- Terminal 15

Note: The PC board is not serviceable

Within the distribution box itself fuses and relays are plugged directly into the PC board as well as directly into the wiring harness.

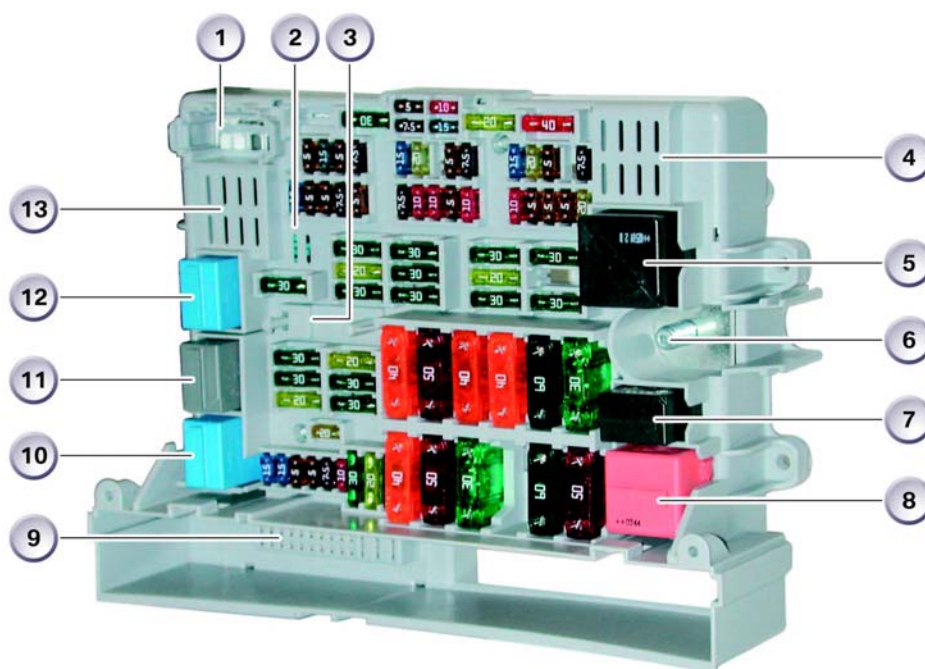

Index	Explanation	Index	Explanation
1	Wiring Harness Connector	8	Relay Secondary Air Pump
2	Horn Relay (PC Board)	9	Internal Interface, Junction Box Control Module
3	Terminal 30_g_f Relay (PC Board)	10	Relay for Rear Window Wiper
4	Terminal 15 Relay (PC Board)	11	Relay for Rear Window Defogger
5	Terminal 30g Relay	12	Relay for Wiper Stage 1
6	Power Supply	13	Relay for Wiper Stage 2 (PC Board)
7	Relay for Windshield Washer		

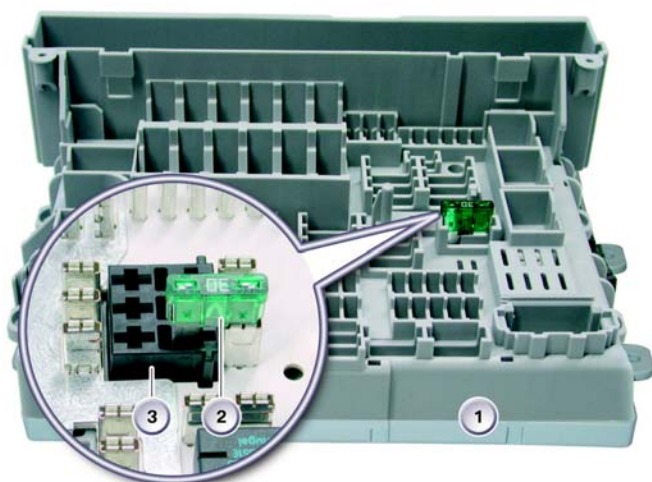

Index	Explanation
1	Junction Box Housing
2	Fuse
3	Wiring Harness Connector

The upper left corner of the junction box provides an interface connection directly to the vehicle wiring harness for the purpose of relay activation and supplying power to various loads.

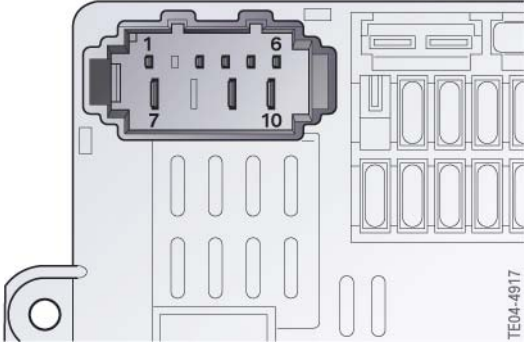

Pin	Explanation	Pin	Explanation
1	Secondary Air Pump Activation (Gnd)	6	Activation Term. 30g (Gnd)
2	-----	7	Ground
3	Terminal 87, DME Secondary Air Pump	8	-----
4	Activation of Electric Fuel Pump, (Gnd)	9	Working current, wiper stage 1
5	Activation Term. 15 (Pos)	10	Working current, wiper stage 2

Junction Box Electronic Control Module (JBE)

Not only does the Junction Box serve as a power distribution center it also provides additional functions as a result of having an Electronic Control Module. The electronic control module is the Gateway Module for the vehicles bus systems, plus processes various signals pertaining to:

- Power Windows
- Climate Control
- Heated Washer Jets
- Wiper Washer System
- Seat Heating
- Relay KL30g_f (Bistable)
- Central Locking
- Mirror Heating
- Instrument Cluster Functions

The Junction Box Electronic control module (JBE) also controls the operation of a number of different relays that are either internal or external to the module.

Relays that are controlled by JBE:

Internal Relays

- Power Window Drive - Rear
- Central Locking Drive (except trunk)

External Relays

- Heated Rear Window/Defrost
- Headlight Washer
- Bistable Term. KL30g_f - deactivation of off load power consumers
- Wiper Stage 1 & 2

The JBE module use four connectors to establish connection to the instrument cluster, vehicle wiring harnesses and to the distribution box itself.

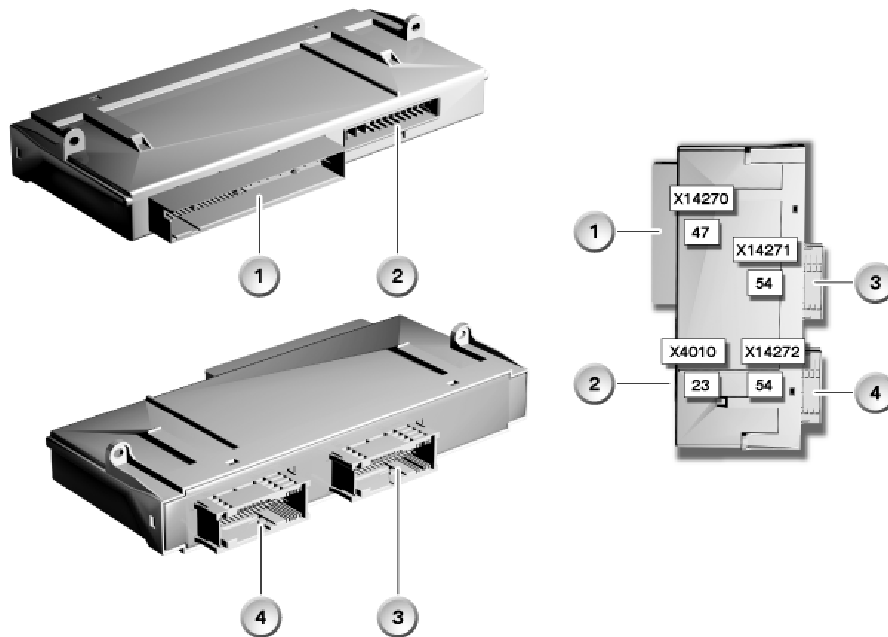

Index	Explanation	Index	Explanation
1	Connector X14270 (47 Pin) - Wiring Harness	3	Connector X14271 (54 Pin) Wiring Harness
2	Connector X4010 (23 Pin) - Power Dist Box	4	Connector X14272 (54 Pin) Instrumentation

The Distribution Box interface/connection point (X4010) to the Electronic Control Module is located in the lower left corner of the Junction Box

Interface/Connection Point (X4010):

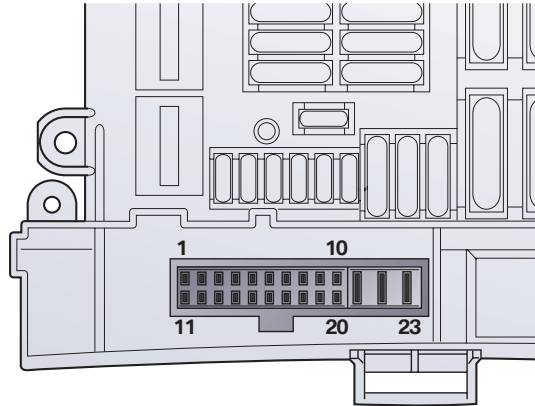

Pin	Explanation	Pin	Explanation
1	Diagnosis, Rear Window Defogger	13	Term. 30g_f, switch-on (Gnd)
2	Diagnosis, Rear Window Wiper	14	Activation, Wiper Stage 1 (Gnd)
3	Term. 30_E (Connection is not fuse-protected)	15	Diagnosis, Wiper Stage 1
4	Activation of Rear Window Wiper (Gnd)	16	Activation, Wiper Stage 2 (Gnd)
5	Voltage Supply, Central Locking, Term. 30/F56	17	Activation, Horn (Gnd)
6	Voltage Supply, Central Locking, Term. 30/F57	18	Diagnosis, Wiper Stage 2
7	Voltage Supply, Kombi/OBD socket, Term. 30/F58	19	Activation, Windshield Washer System
8	Voltage Supply, Steering Column Switch Cluster, Term. 30/F59	20	Diagnosis, Windshield Washer System
9	Voltage Supply, IHKA, Term. 30/F60	21	Voltage Supply, Left Rear Power Window F64
10	Voltage Supply, Central Information Display, Terminal 30/F60	22	Voltage Supply, Junction Box Control module F63
11	Term. 30g_f, Switch-off (Gnd)	23	Voltage Supply, Right Rear Power Window F62
12	Activation of Rear Window Defogger (Gnd)		



Classroom Exercise - Review Questions Junction Box

1. What function does the Junction Box serve?

2. What function does the Junction Box Electronics control module serve?

3. What relays are soldered to the circuit board?

4. What systems do the relays on the JBE circuit board impact?

Bus Systems

The bus structure in the new BMW 3 Series (E90) builds on the technology being used in the current models. In the E90 the Junction Box Electronic Control Module (JBE) serves as the Gateway Module for the bus system, meaning that the JBE is the connection point for the K-CAN, PT-CAN and D-Bus. The Junction box only serves a pass through function for the F-CAN, data is not transferred by the JB to other systems for this bus. With the E90 an additional module, the FRM, is connected to the PT-CAN to receive the brake light signal from the LDM.

As a result of the increase in the inter connecting of control modules some sensors are no longer connected to the main control module for that system, but rather to the control module closest to the sensor or actuator and then the information is transferred to the main controller via the main bus system. By utilizing the closest module as a data transfer point cable length and the number of connectors is reduced.

Within the vehicle two groups of bus systems are used:

- Main bus system (K-CAN, PT-CAN, MOST, F-CAN)
- Sub-Bus system (LIN-Bus, BSD, K-Bus, K-Bus (protocol))

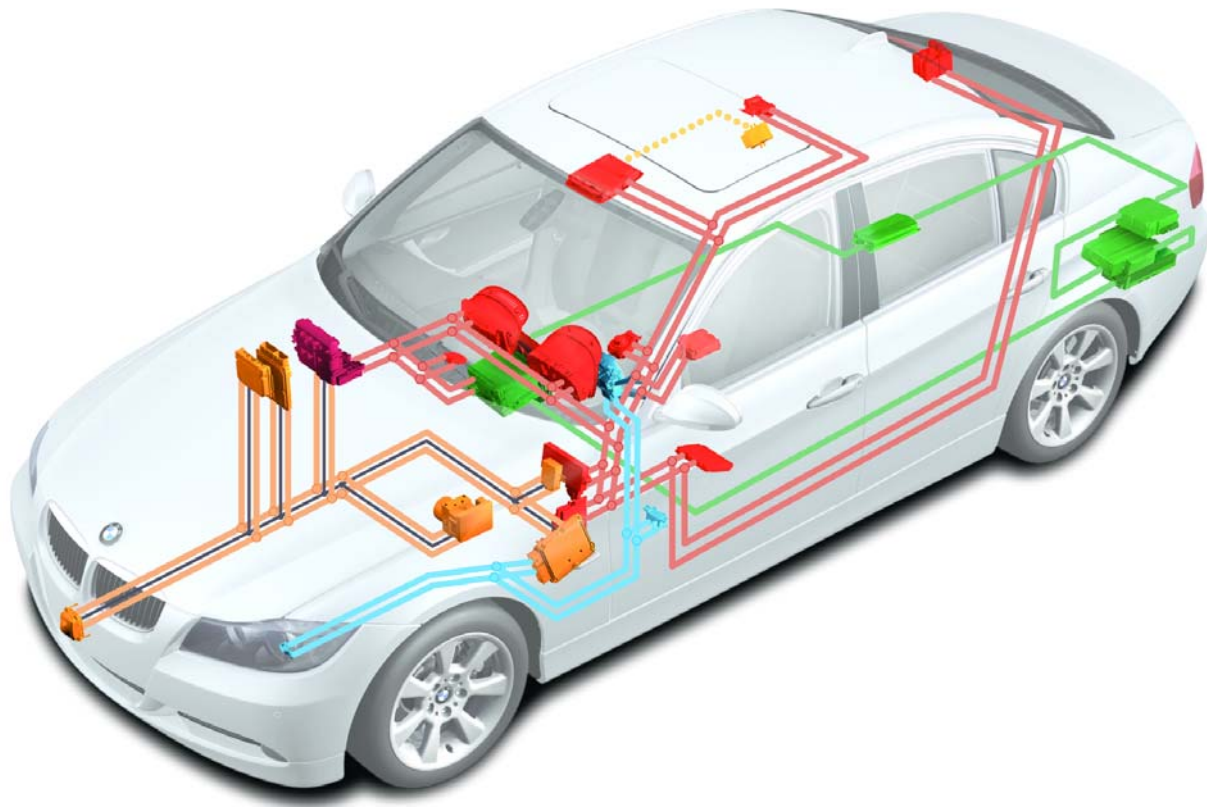

Main bus systems are responsible for the data exchange between the control modules throughout the vehicle system.

Example: *The status of the door contacts is read in via the Footwell Module (FRM) when the doors are locked on the BMW 3 Series. The information is transmitted via the K-CAN to the Junction Box Control Module which in turn activates the central locking drive units.*

Sub-Bus systems are used to exchange relatively small quantities of data within one defined system.

Example: *The data of the rain and driving lights sensor (RLS) is read by the Roof Functions Center (FZD) and forwarded via the K-CAN to the Junction Box Control Module (JB) and Footwell Module (FRM). The connection provided between the RLS and the FZD is a sub-bus known as LIN-Bus.*

Group	Bus System	Data Rate	Structure
Main	D-Bus (Diagnostic Bus)	10.5/115 Kbit/s	Linear, Single-Wire
Main	K-CAN (Body Bus)	100 Kbit/s	Linear, Two-Wire
Main	PT-CAN (Powertrain-CAN)	500 Kbit/s	Linear, Two-Wire
Main	F-CAN (Chassis CAN)	500 Kbit/s	Linear, Two-Wire
Main	MOST	22.5 Mbit/s	Ring, Fiber Optic
Sub	K-Bus (Body Bus)	9.6 Kbit/s	Linear, Single-Wire
Sub	K-Bus (Protocol Body Bus)	9.6 Kbit/s	Linear, Single-Wire
Sub	LIN-Bus (Local Interconnect Network Bus)	9.6/19.2 Kbit/s	Linear, Single-Wire
Sub	BSD (Bit Serial Data Interface)	9.6 Kbit/s	Linear, Single-Wire

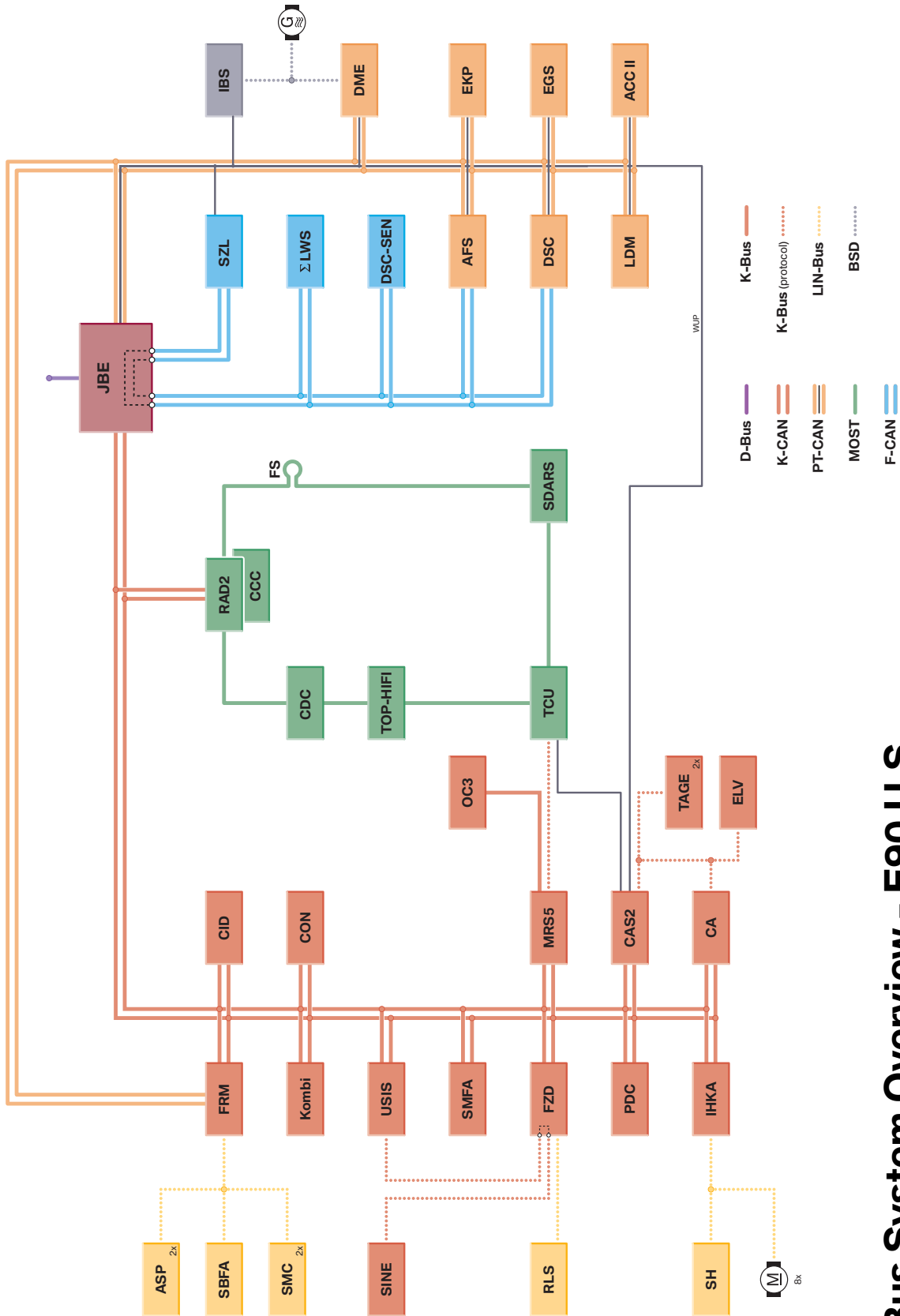

Bus System Overview - E90 U.S.

Legend for Bus System Overview - E90 U.S.

Index	Explanation	Index	Explanation
ACC II	Active Cruise Control 2	K-Bus	Body Bus (protocol)
ASBPF	Front Passenger's Side Outside Mirror	K-CAN	Body CAN
ASPFA	Driver's Outside Mirror	KOMBI	Instrument Cluster
CA	Comfort Access	LDM	Longitudinal Dynamics Management
CAS2	Car Access System 2	LIN-Bus	Local Interconnect Network Bus
CCC	Car Communication Computer	MOST	Media Oriented System Transport
CDC	CD Changer	MRS5	Multiple Restraint System 5
CID	Central Information Display	PDC	Park Distance Control
CON	Controller	PT-CAN	Powertrain CAN
D-Bus	Diagnosis Bus	RAD2	Radio 2 (BMW Professional)
DME	Digital motor Electronics	RLS	Rain/Lights Sensor
DSC	Dynamic Stability Control Module	SBFA	Switch Block, Driver's Door
DSC-SEN	DSC Sensor	SH	Independent Heating (Seat)
EGS	Electronic Transmission Control Module	SINE	Emergency Current Siren with Integrated Tilt Alarm Sensor
EKP	Control Module for Electric Fuel Pump	SMCBF	Stepper Motor Controller, Front Passenger
ELV	Electric Steering Lock	SMCFA	Stepper Motor Controller, Driver
F-CAN	Chassis CAN	SMFA	Seat Module, Driver's Side
FRM	Footwell Module	SZL/LWS	Steering Column Switch Cluster/Steering Angle Sensor
FS	MOST Direct Access	TAGE	Electronic Outer Door Handle Module
FZD	Roof Function Center	TCU	Telematics Control Module
IBS	Intelligent Battery Sensor	TOP-HIFI	Top HiFi Amplifier
IHKA	Automatic Climate Control	USIS	Ultrasonic Passenger-Compartment Sensor
JBE	Junction Box Electronics Control Module	WUP	Wake-up Line

K-Bus

The K-Bus serves the purpose of linking the OC3 mat (Seat Occupancy Recognition) to the MRS 5 Control Module.

K-Bus (protocol)

The term "K-Bus (protocol)" is used for a series of sub-bus systems for various purposes. The K-Bus protocol used here is a common component used in previous models.

In the E90 this sub-bus is used in connection with the following systems:

- Anti-theft Alarm System (DWA-Bus/K-Bus)
- Connection between MRS5 and TCU
- Electronic Outer Door Handle Module (TAGE) - (CAS-Bus/K-Bus)
- Electromagnetic Steering Wheel Lock (ELV) - (CAS-Bus/K-Bus)

LIN-Bus

The LIN-Bus was used for the first time on the E46 for controlling the outside mirrors. On the new BMW 3 Series the LIN-Bus is used for the following connections:

- Connection from the FRM to the driver's side switch cluster (19.2 Kbit/s)
- Connection from the RFZ to the RLS (19.2 Kbit/s)
- Driving actuators IHKA (9.6 Kbit/s).

BSD

The bit-serial data interface BSD is also used on the BMW 3 Series for the purpose of connecting the alternator and the Intelligent Battery Sensor (IBS) to the Engine Control Module ECM/DME).

Terminating Resistors

Terminating resistors are used to ensure exact data transmission in the bus systems and are located in the control module of the various bus systems.

Terminating resistors for:

- K-CAN are located in each control module connected to the bus
- F-CAN are located in only two module on the bus (SZL and DSC)
- PT-CAN are located in only two modules on the bus (EKP and DSC)

MOST Bus

The new 3 series (E90) uses a MOST-Bus structure, similar to that used on E60/61/63/64/65/ & E66, as a means of connecting the Information and Communication Systems (IKT).

MOST is a data bus technology developed & standardized for automotive applications and stands for Multimedia Oriented System Transport. Devices connected on the MOST bus use light pulses to communicate/transmit data from one device to the other. The communication on a MOST-Bus structure is only in one direction around the ring. The advantage of a MOST-Bus structure over a CAN or LIN-Bus is that it can not only transmit control and sensor data but can transmit digital audio, video signals and transport graphics as well.

The gateway/master controller on the MOST-Bus is either RAD2 or the CCC depending on vehicle options installed. The master controller is responsible for data exchange between the MOST-Bus and the other bus systems as well as retaining the registration file for the control modules installed on the MOST-Bus.

The registration file stores information regarding the modules installed as well as their sequence on the MOST-Bus. With the fibre optics connectors, it is possible to connect control units in the rear area of the BMW 3 Series after a repair in a different order than they were installed from the factory. The BMW diagnosis system can determine the installed control units and their order by accessing the information in the registration file.

During the start-up procedure, all control module on the MOST-Bus send their identifier to the master controller. In this way, the master controller can detect what control modules are connected to the MOST-Bus. A corresponding fault can be set in diagnosis if the login of one or several control modules is not received.

Light Direction

Each control module on the MOST-Bus is able to send data, however it can only be sent in one direction.

The physical light direction is from the master controller (Rad2 or CCC) to the fibre optics connector (located in rear of vehicle) and from here to the control modules in the luggage compartment (CD Changer, Top HiFi Amplifier, TCU, SDARS etc.). From the last control module, the light returns via the MOST-direct access port to the master controller.

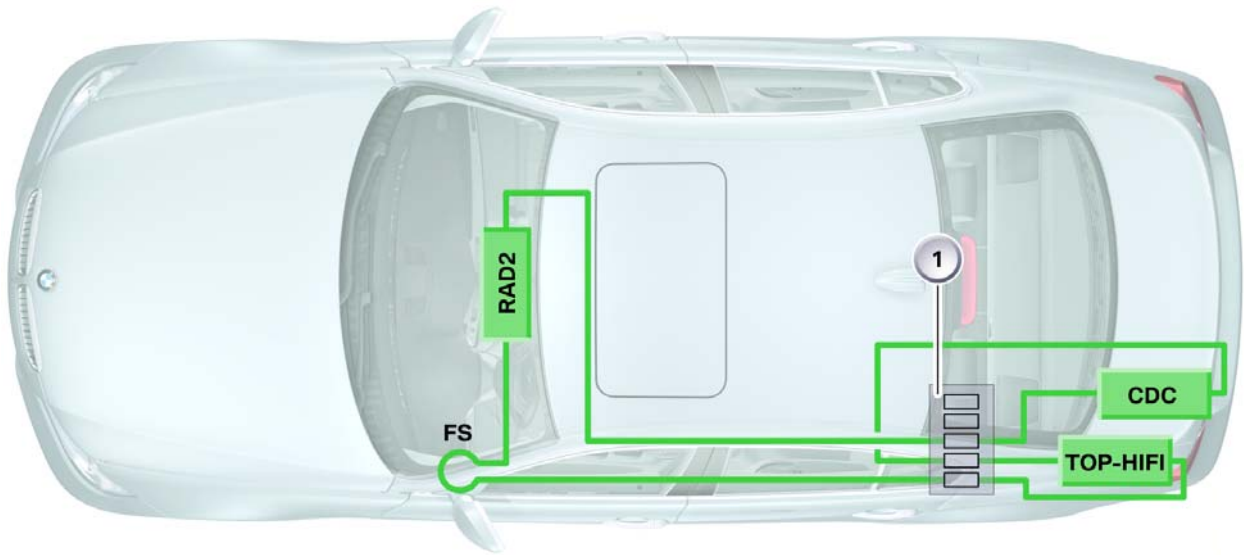

Index	Explanation	Index	Explanation
RAD2	Radio 2	1	Fiber Optics connector
TOP-HIFI	Top HiFi Amplifier	FS	MOST Direct Access (port)
CDC	CD Changer		

Fiber Optics Connector

The use of a fiber optics connector provides the advantage of being able to easily retrofit control modules in the area of the luggage compartment. The fibre optics connector is located behind the left-rear lateral seat back trim panel, next to the rear seat backrest.

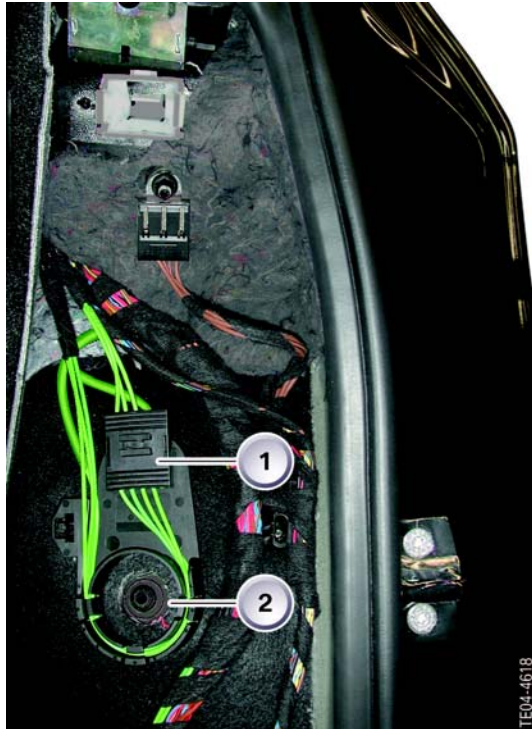

A cable duct is provided in addition to the fiber optics conductor to avoid excessively small radii (bends) in the fiber optic conductors. The master controller is always connected in the luggage compartment, alongside various options.

One or two fiber optic connectors are installed depending to the equipment configuration. One fiber optics connector is responsible for the factory-installed control modules. The other fiber optics connector is used for the installation of additional options/accessories.

The ends of the fiber optics conductors for options are always grouped together on the same row in the fiber optics connector to avoid damage to the ends of the fiber optics conductors.

As soon as the retrofit is installed, the fiber optics connectors are reconnected according to instructions and integrated in the MOST-Bus.

Index	Explanation
1	Fiber Optics Connector
2	Installation Aid for Fiber Optic Conductors

■ Identification of Fiber Optics Conductors

The fiber optics conductors are identified at their ends. The identification indicates the control unit from which the fibre optics conductor comes or goes.

Diagnosis Information

■ Data Flow Interruption

Several factors can cause an interruption in the data flow in the MOST-Bus:

- Power supply of transmitting control module defective
- Internal fault in transmitting control module
- Transmitter in transmitting control module defective
- Power supply of receiving control module defective
- Internal fault in receiving control module
- Receiver in receiving control module defective
- Break in the fiber optics conductor between transmitting and receiving module

With the ring break diagnosis and the optical test, it is possible to determine whether and where there is a break or interruption within the MOST-Bus.

Initially for this purpose, the power supply to the control modules in the MOST-Bus is disconnected. When the power supply is switched on again, all control modules send light to the next control module in the direction of light. The control module that receives no light at its input stores the node position 0 in its fault code memory. This means the ring break is between the control module with the node position 0 and the control module located before it.

The master controller can also be accessed as a check in the case of fault. The master controller is always connected to the K-CAN and can therefore also be addressed for fault diagnosis purposes.

■ Overtemperature Shut-Down

If the internal control module temperature exceeds a certain value (approx. 80°C) the control module is switched off for 10 minutes in order to protect the internal components. After this time has elapsed, the control module is switched on again and is fully operational. The entire MOST-Bus is shut down if the affected control module is the master controller (RAD2 or CCC), for all other control modules on the MOST-Bus, only the specific module is switched off if it overheats.

NOTE: Modules located in the area of the luggage compartment such as TCU or Top HiFi amplifier or SDARS can generate very high temperatures.

In the event of an overtemperature shutdown corresponding fault entries are made in the fault code memory of the respective control module which can be evaluated with the BMW diagnosis system.

NOTES

PAGE



Classroom Exercise - Review Questions Bus Systems

1. What module serves as the main gateway?

2. What module(s) serve as the controller/gateway for the MOST-Bus?

3. Identify the various bus structures and what role they have.

4. What are terminating resistors?

5. Where are the terminating resistors located?

Power Management

A power management function somewhat similar to that used in the E60 is also used in the E90 to ensure balanced power/energy distribution in the vehicle. The power management functions are incorporated into the software of the Engine Control Module (ECM/DME).

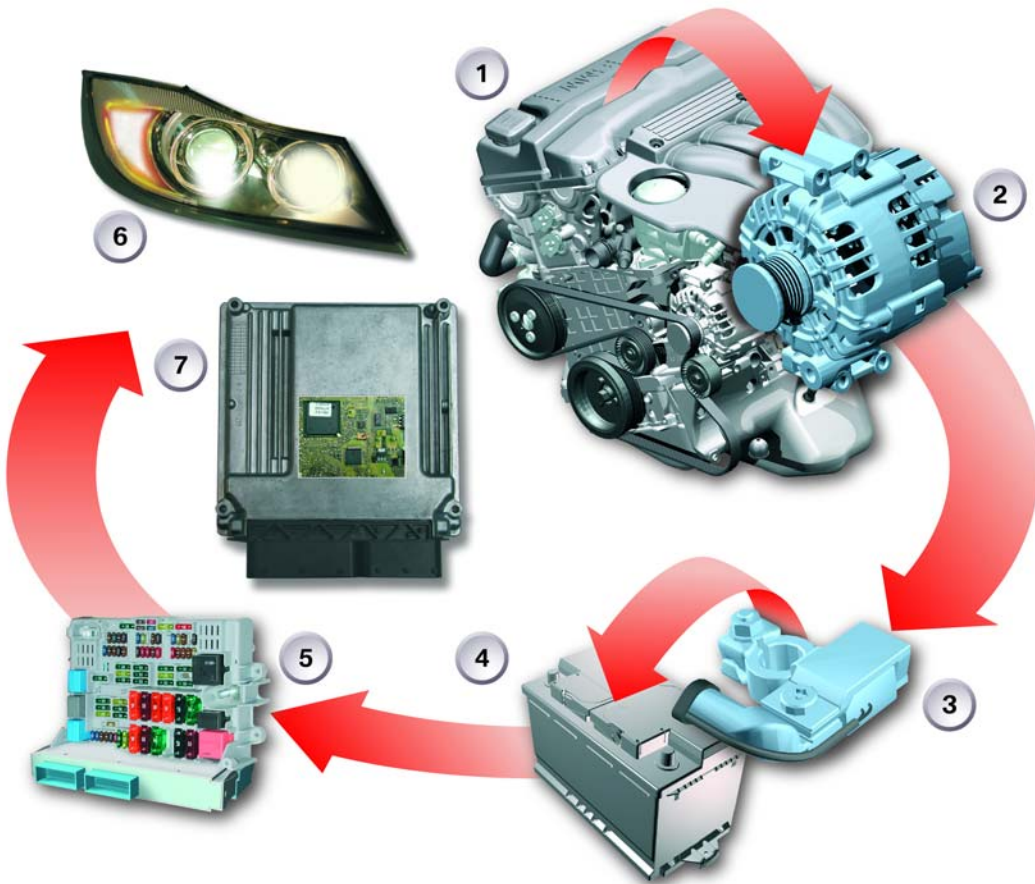

Index	Explanation	Index	Explanation
1	Engine	5	Junction Box
2	Alternator	6	Electrical Loads
3	Intelligent Battery sensor (IBS)	7	Engine Control Module
4	Battery		

Since the IBS is able to provide exact information on the condition of the battery such as actual battery voltage, current and temperature to the DME, this allows for greater flexibility in regulating loads and also provides additional diagnostic functions with regard to energy consumption as well.

Power Consumption During Operation

During vehicle operation, the mechanical energy of the engine is converted by the alternator into electrical energy and made available to the various electric loads. The electric loads receive power primarily via the terminal 30g and 30g_f relays located in the junction box. Certain electric loads are supplied directly by terminal 30 or by terminal R. For example, the anti-theft alarm system must still remain active when the vehicle is parked.

The calculations necessary for controlling the energy balance take place within the power management portion of the DME operating program. The power management program is able to:

- Regulate the idle speed and charging voltage while the engine is running
- Regulate power consumption of electric loads with relatively high power demands or switch off loads as required.
- Switch-off certain electric loads when the engine is stationary either as a time controlled function via the CAS 2 and the terminal 30g relay or in response to electrical faults via the engine control, junction box and the terminal 30g_f relay.
- Generate system faults to perform vehicle or battery diagnosis

Idle Speed Boost

Although the alternator may be operating at maximum speed, the idle speed can be increased by up to 200 RPM as soon as current is drawn from the battery.

Electric Load Reduction - Engine Running

In addition to increasing the idle speed and the specified charging voltage, the output of various electric loads can be reduced or loads can be switched off in order to reduce the power consumption in critical situations. The electric loads are shut down only under the following two conditions:

- Battery charge status in critical range
- Alternator fully utilized

The following measures are implemented if the above conditions occur:

Function	Operation	Control Module
1. Rear Window Defroster	Clocking	IHKA
2. Seat Heating	Stage 2	SM/JB
3. Seat Heating	50%	SM/JB
4. Heater Blower	75%	IHKA
5. Heater Blower	50%	IHKA
6. Mirror Heating	Off	FRM
7. Rear Window Defroster	Off	IHKA
8. Seat Heating	Off	SM/JB
9. Heater Blower	25%	IHKA

Electric Load Cut-Off with Engine Off

Certain electric loads may be active although the engine is off and the closed-circuit current monitoring feature of the power management function is in operation.

The electric loads in the vehicle are divided into the following groups:

- Legally required electric loads (i.e. side lights, hazard warning system)
- Convenience for the customer (i.e radio, telephone)

These electric loads are excluded from the closed-circuit monitoring system in order to avoid misinterpretation by the power management function, however these electric loads must log in with the power management function. In turn, the power management function recognizes the activity and accepts the higher power consumption until the systems are deactivated and these control modules log off with the power management function.

The power management function within in the DME can send a request to switch off active electric loads in stationary mode depending on the battery charge status and the start capability limit. As a result of the request, the stationary loads must deactivate their functions irrespective of the terminal status and must reach their closed-circuit current within 5 minutes. Legally required electric loads are excluded from this function.

The E90 uses four relays that are installed in the Junction Box, for the purpose of switching off the power supply to the majority of the control modules when the vehicle is in a stationary status. The four relays are:

- Terminal 30g - Circuit activation by the CAS
- Terminal 30g_f - Circuit activation by the Junction Box control module (JBE) which monitors the following activities:
 - Invalid wake-up procedures within the bus systems
 - Events that prevent sleep mode (control units that keep the bus systems constantly active)

Note: Since the DME constantly reads and evaluates the battery values the terminal 30g_f relay can also be switched off via a request from the DME if the start capability limit of the battery is reached.

- Terminal 30 - Circuit Activation by the CAS
- Terminal 15 - Circuit Activation by the CAS

Terminal 30g Relay (Time-Dependent Deactivation)

The terminal 30g relay is controlled by the CAS, which switches off the connected control modules after 30 minutes if the engine was running for an extended period. The switch of time is extended to 60 minutes if a telephone system is installed in the vehicle.

The terminal 30g relay is controlled by the car access system and supplies power to the systems indicated below.

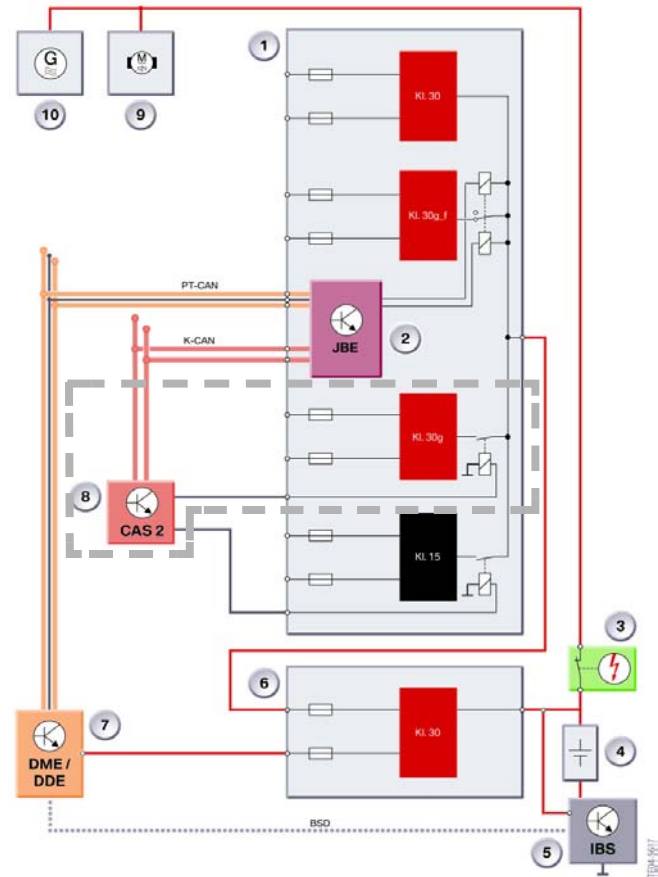

Workshop Exercise:

Highlight modules that use Terminal 30g

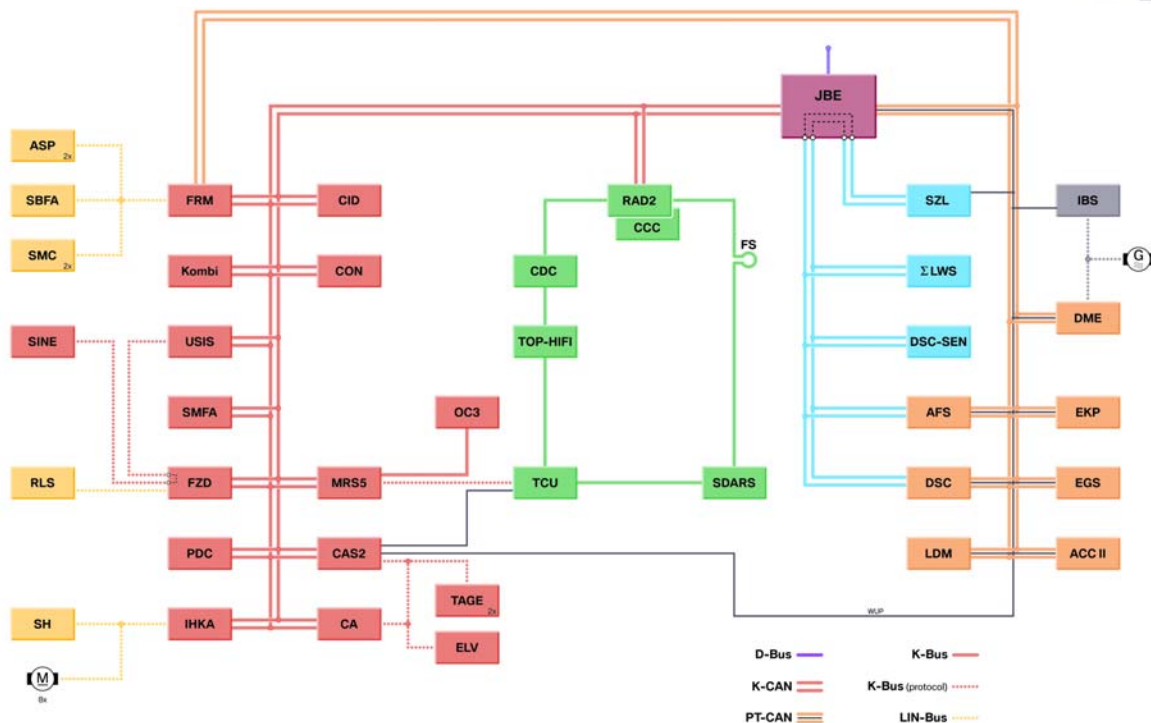

Control modules connected to Terminal 30g

*Basic radio not available in U.S. market

Terminal 30g_f Relay (Fault-Dependent Deactivation)

The Junction box control module controls the 30g_f terminal, which is primarily a terminal 30 circuit that is only switched off if a fault is detected.

A bistable relay is used to control terminal 30g_f by means of two coils, one to open the circuit and one to close it, each coil is controlled by the Junction Box control module. Each coil is supplied directly by KL.30, the JB control module grounds the respective coil in order to open or close the relay. The relay is normally in the “On” state and supplies KL.30 to two fuses (17 & 40). The switch status/position of the relay is retained even when no power is applied.

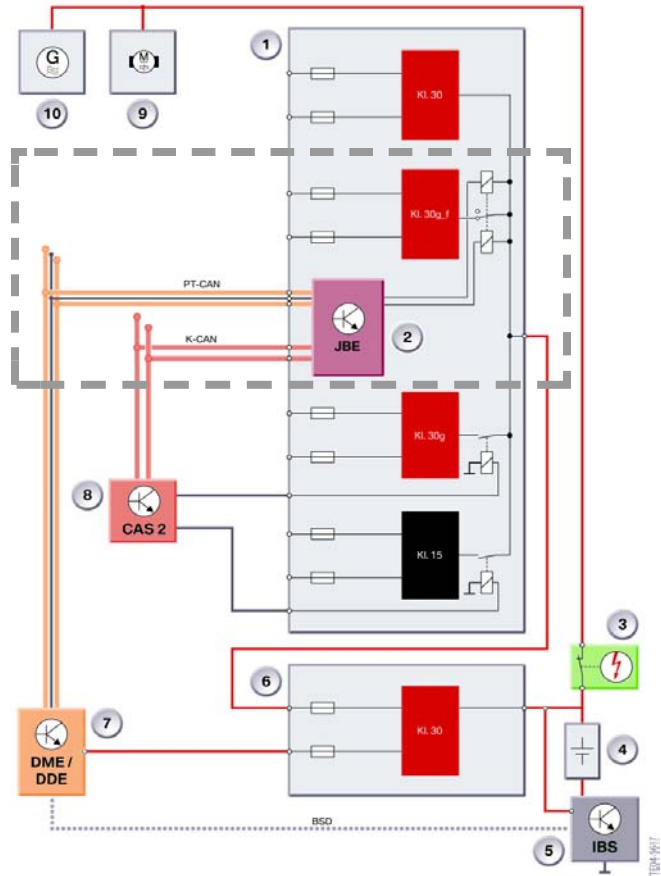

Workshop Exercise:

Highlight modules that use Terminal 30g_f

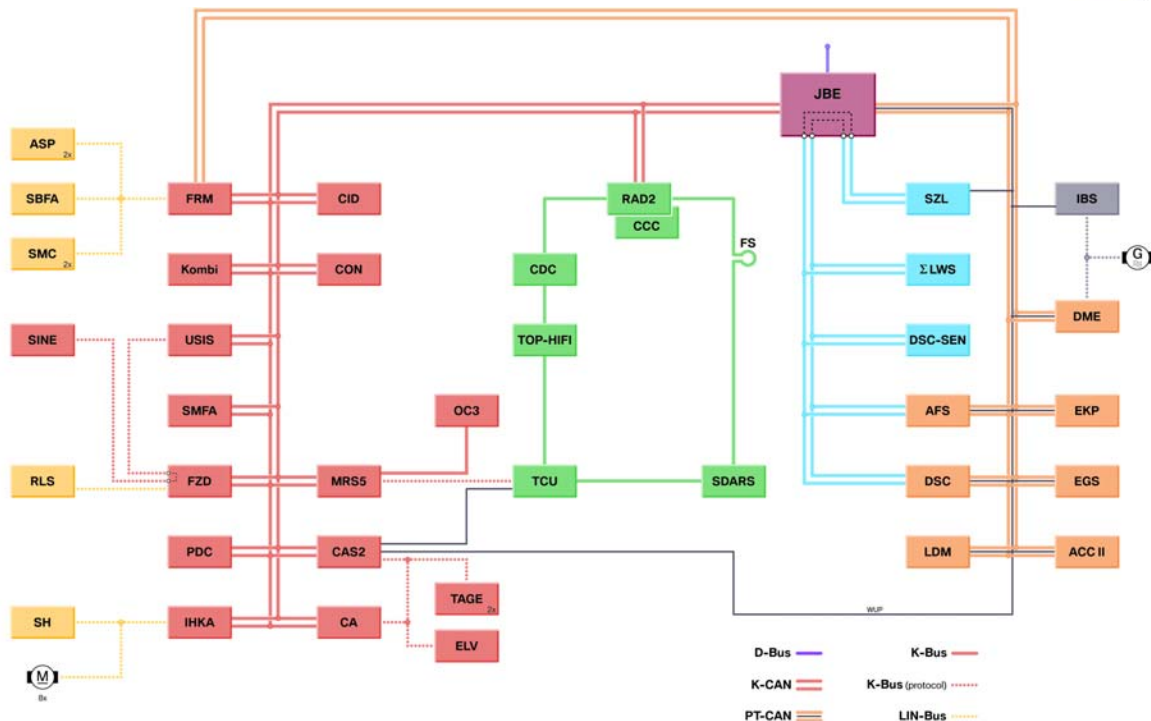

Control modules connected to Terminal 30g_f

Terminal 30g_f is switched ON with:

- Vehicle unlocked
- Terminal change from R “Off” to R “On” or terminal 15
- Change in contact status for the trunk, hood or any door

Note: The relay only needs to be switched on if it was previously turned off, otherwise the relay is in the “On” position.

Terminal 30g_f is switched OFF when:

- With terminal R off, the DME detects, via the IBS, that the starting capability limit has been reached (battery capacity is just enough to start the vehicle).
- After 30/60 minutes of terminal R off, JB detects that control modules are preventing the vehicle from entering the sleep mode.
- With terminal R off, the JB counts more than 30 wake-ups at terminal R.

Once the terminal 30g_f relay has been switched off, one of the switch-on conditions is necessary in order to switch it on again. If the fault that caused the relay to switch off is due to a closed-circuit current fault, a fault code is stored in the memory of the junction Box.

Note: No indication of which module is responsible for the closed-circuit current fault is provided.

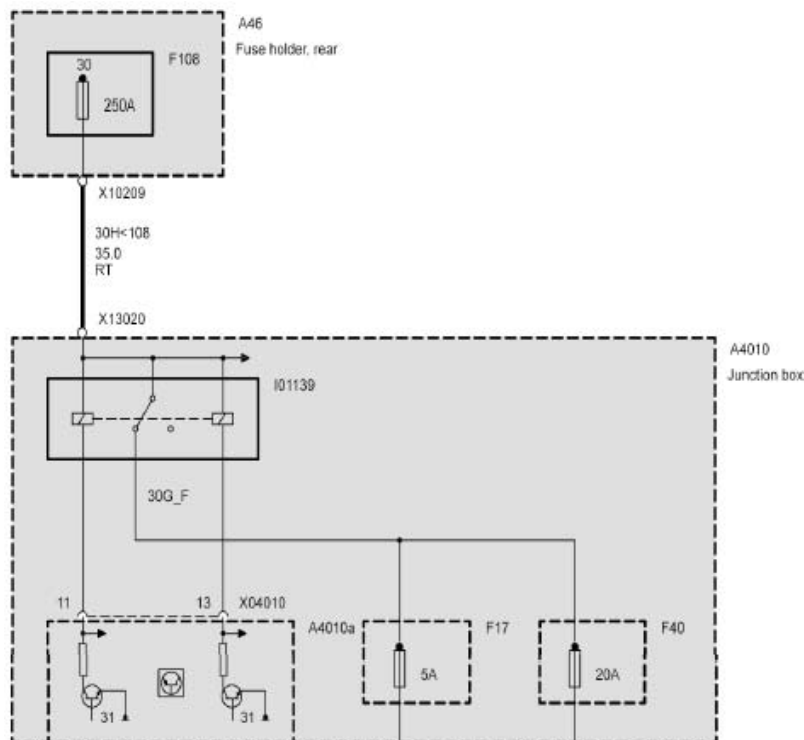

Terminal 30 (KL30)

A number of control modules are connected to terminal 30 via the junction box.

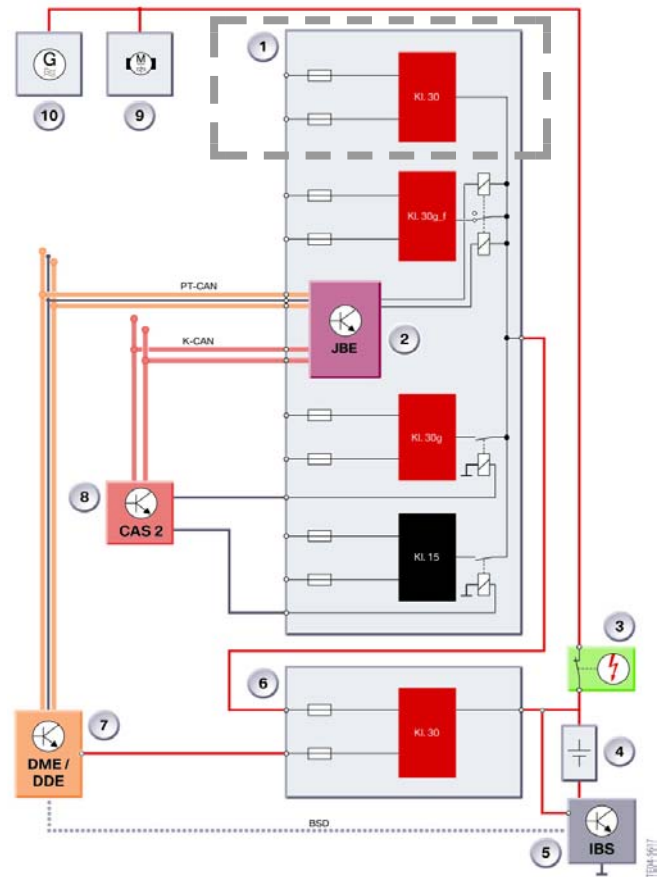

Workshop Exercise:
Highlight modules that use Terminal 30 (KL30)

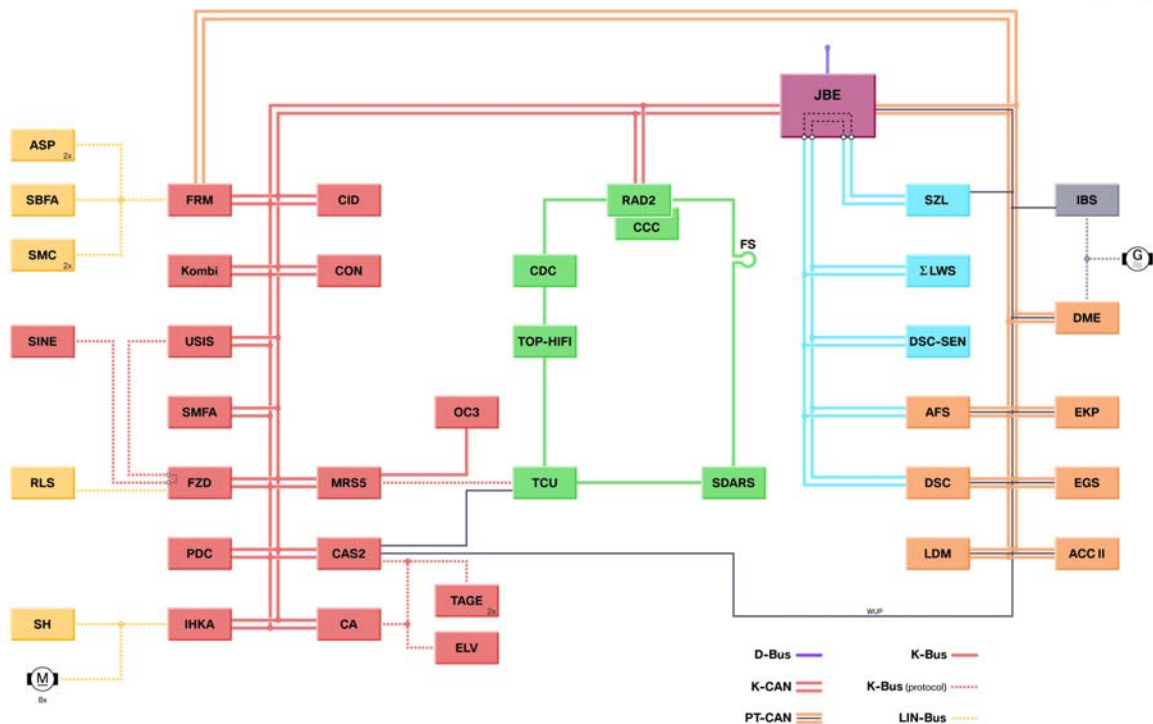

Control Modules Connected To Terminal 30

Terminal 15 (KL15)

The only module on the BUS effected by Terminal 15 relay is the PDC Control Module.

The terminal 15 relay in the Junction Box is deactivated by the CAS.

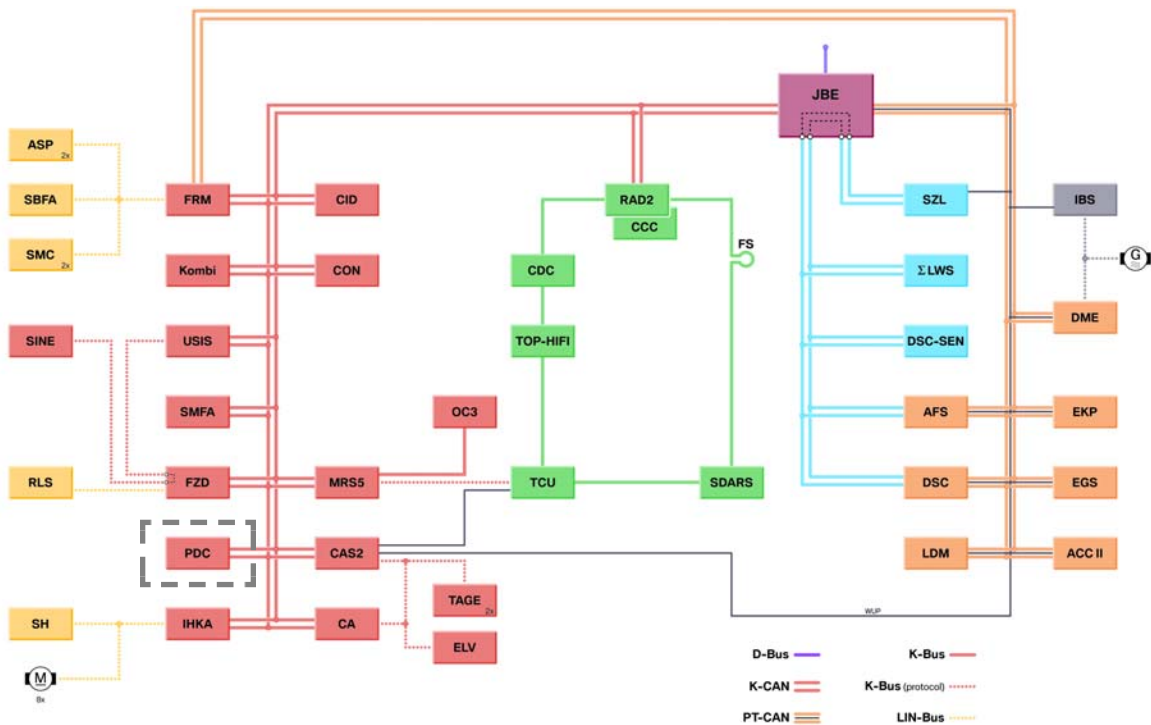
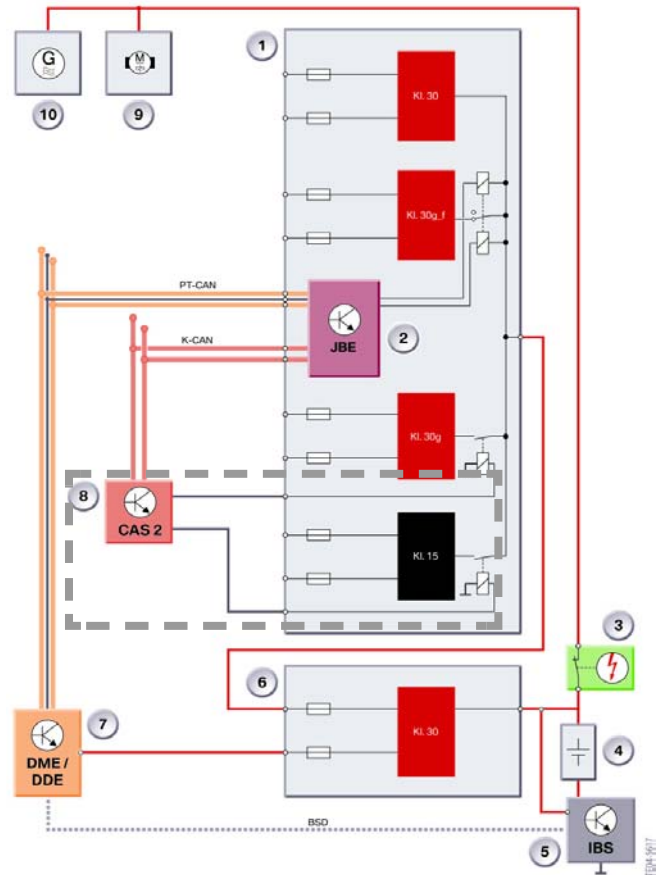

System Diagnosis Information

The control modules for the DME/ECM and Junction Box (JB) provide various forms of information for the purpose of establishing effective system & Battery diagnosis:

DME/ECM stores various data that can be used for energy diagnosis, such as:

- With an IBS installed the last 32 cycles of closed circuit current monitoring data are stored
- Last registered battery replacement
- Accumulated mileage over past five days

The Junction Box Electronics stores information pertaining :

- Max number of unexpected wake-ups at with Term R within last 5 weeks
- Last 5 control modules that prevented the vehicle from going to sleep, plus mileage reading for each event
- Driving profile for the past 5 weeks

Since a Terminal 30g_f relay is installed, information pertaining to the cause/reason for shutting off of terminal 30g_f such as:

- With terminal R off, the DME detects, via the IBS, that the starting capability limit has been reached (battery capacity is just enough to start the vehicle).
- After 30/60 minutes of terminal R off, JB detects that control modules are preventing the vehicle from entering the sleep mode.
- With terminal R off, the JB counts more than 30 wake-ups at terminal R.

Once the terminal 30g_f relay has been switched off, one of the switch-on conditions is necessary in order to switch it on again. If the fault that caused the relay to switch off is due to a closed-circuit current fault, a fault code is stored in the memory of the Junction Box.

The BMW diagnosis system can access and evaluate this information and facilitate an assessment of the history values and indicates the most probable cause of the problem.

■ Closed Circuit Current

The closed-circuit current on the E90 is:

- Approx. 22 mA on fully equipped US vehicles.

A check control message is displayed if a closed-circuit current value of 80 mA was encountered while the vehicle was stationary.

The following diagrams show a typical closed-circuit current progression for the E90 in connection with the various operating modes of the vehicles electrical system, with vehicle secured and not secured. The actual current values may change depending on the vehicles equipment level.

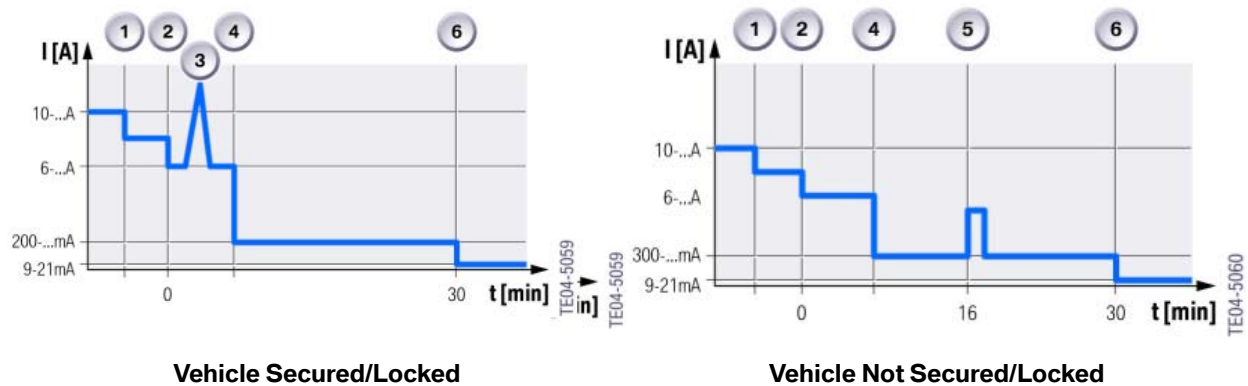

Index	Explanation
1	Terminal 15 OFF
2	Terminal R OFF
3	Vehicle Secured/Locked
4	Start of Bus Rest Phase
5	Electric Load Shut-Down (Terminal 30) after 16 Minutes if Vehicle is Not Locked
6	Terminal 30g OFF (30 Minutes without TCU or 60 Minutes with TCU)

The electric load shutdown terminal 30 (VA) for interior, footwell, reading and vanity mirror lights is switched off immediately when the vehicle is secured/locked. If the vehicle is not locked after the engine was running, for an extended time, terminal 30 (VA) is switched off after 16 minutes. The function is activated by the footwell module.

Transport Mode

The following functions are switched off and on in the E90 when vehicle is placed into transport mode.

Index	Function	Module	Transport Mode (O-On/X-Off)
1	Mirror heater (driver's door)	FRM	X
2	Mirror heater (passenger's door)	FRM	X
3	Follow-me-home" lighting "	FRM	X
4	Side light	FRM	X
5	Parking light	FRM	X
6	Interior light	FRM	O
7	Limiting VA/IB time from 16 min to 1 min (interior light, reading light, luggage compartment light etc.)	FRM	O
8	Rear window roller blind	JB	X
9	Seat heating (driver/front passenger)	JB	X
10	Mirror heating	JB	X
11	Disconnection of bistable relay after coded time	JB	O
12	Radio remote control (including boot lid release) can be used only with bus active	CAS	O
13	Limiting 30g time from 30 min to 5 min	CAS	O
14	Reducing terminal R active time from 16 min to 2 min, irrespective of operating status of door contact	CAS	O
15	Slide/tilt sunroof	FZD	X
16	Limiting VA/IB time from 16 min to 1 min (interior light, reading light, luggage compartment light etc.) FRM is master in this case	FZD	X
17	DWA	DWA	X
18	Rear window defogger	IHR/IHKA	X
19	Blower (limited to max. 90 %)	IHR/IHKA	O
20	Compressor	IHR/IHKA	X
21	Auxiliary heater (PTC)	IHR/IHKA	X
22	Independent heating (if planning status)	IHR/IHKA	X
23	Defrost (100 % blower output possible)	IHR/IHKA	O
24	Auxiliary water pump	IHR/IHKA	X
25	Radio control	RAD1	X
26	Car communication computer operation +"master function" (passive)for deactivation of: radio function, Top HiFi amplifier, audio CD changer, antenna amplifier	CCC	X

Transport Mode Cont.

Index	Function	Module	Transport Mode (O-On/X-Off)
27	Radio control master function for deactivation of: Top HiFi amplifier, telephone	RAD2	X
28	Central information display, function keys	CID	X
29	Controller	CON	X
30	Telematics function	TCU	X
21	Telephone control, prevent wake-up of MOST-Bus	TCU	X
32	Seat heating (driver/front passenger)	SM	X
33	Comfort access, deactivation of TAGE	CA-SG	X



Workshop Exercise - Power Management

Identify/Highlight specific control modules related to the following requests.

Identify the control modules located on the terminal 30g circuit. (refer to page 36)

Identify the control modules located on the terminal 30g_f circuit. (refer to page 37)

Identify the control modules located on the terminal 30 (KL30) circuit. (refer to page 39)



Classroom Exercise - Review Questions

1. Under what conditions is the circuit for term.30g_f switched off?

2. Describe the operation of relay 30g_f. What controls it?

3. When is terminal 30g switched off?

4. For U.S. vehicle what should the current draw be in sleep mode? (approx.)

5. What type of information is stored for battery diagnosis? How is the information accessed?
