



This Service Information bulletin supersedes SI B54 02 08 **dated January 2008**.

NEW designates changes to this revision

SUBJECT

Water Leak from Sunroof

MODEL

E60 (5 Series)

SITUATION

After periods of heavy rainfall, water or residual moisture may be found in one or more of the following areas:

- Rear area of the headliner
- C-pillar trim panels
- Rear seat floor or under the rear seat
- Various areas of the vehicle's trunk.

CAUSE

1. Clogged or disconnected sunroof drains
2. Poorly sealed sunroof cassette
3. Excessive volume of water entering the sunroof cassette.

CORRECTION

1. Clean out or properly secure the sunroof drains.
2. Perform a sealing modification to the sunroof cassette.
3. Reduce the amount of water entering the cassette.

PROCEDURE

The following procedures should be carried out in the following order, and should be stopped once the leak has been identified and corrected:

Cause 1 (Clogged or disconnected sunroof drains)

1. Visually inspect the sunroof drains to ensure that they are not blocked by debris and remove as necessary.
2. Inspect for clogs within the drain tubes.
 - a. Blow compressed air through the sunroof drains to ensure that they are not clogged.
 - b. **NOTE:** Use caution when applying compressed air to the drains so the drain tubes do not become separated from the cassette.
 - c. Pour water into each of the drains to ensure that each drain can evacuate water at a similar rate.

Cause 2 (Poorly sealed sunroof cassette)

1. Remove the headliner per repair instruction RA 51 44 011 and water test the sunroof to reproduce the customer complaint.
 - a. While water testing, inspect the rear corner drain pockets of the cassette for any signs of water seeping through between the cassette frame and these drain pockets.

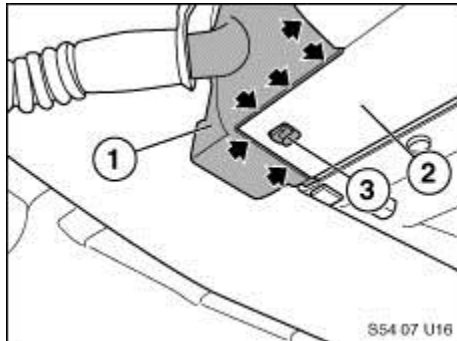

b. If any water seepage is observed, apply sealant to the seam where the drain pocket (1) meets the cassette (2). The retaining tab (3) must also be sealed. Wurth Euroseal Gel or a comparable silicone sealant may be used for this procedure.

c. Seal the opposite side of the cassette in a similar fashion as a preventative measure.

2. Inspect the connection of the drain tube to the cassette for any water seepage.
 - o If any water seepage is observed, seal the drain tube to the cassette using Wurth Euroseal Gel or a comparable silicone sealant.

Cause 3 (Excessive amount of water entering the cassette)

1. Replace the perimeter seal per Repair Instruction RA 54 12 117.
2. Carefully adjust the sunroof glass per Repair Instruction RA 54 12 003.
3. Water-test the vehicle again to ensure that no further leaks are present.

PARTS INFORMATION

Part Number	Description	Quantity
54 13 7 117 551	Perimeter Seal	1 – if necessary

Wurth Euroseal Gel (article # 18920104) may be used for this sealing operation.

WARRANTY INFORMATION

NEW Provided that the water ingress is caused by a defect in material or workmanship, this repair can be claimed under the terms of the BMW New Vehicle Limited Warranty.

Defect Code **54 12 10 48 00**

Cause 1

Main Work*

Labor Operation: 54 99 000 Work time to unclog the sunroof drains

Labor Allowance: Refer to KSD

Cause 2**Main Work***

Labor Operation: 51 44 011 R&I Headliner

Labor Allowance: Refer to KSD

Labor Operation: 54 99 000 **Work time to perform sealing operation**

Labor Allowance: Refer to KSD

Cause 3**Main Work***

Labor Operation: 54 12 117 Replacing seal for glass sunroof lid

Labor Allowance: Refer to KSD

Labor Operation: 54 12 503 Adjusting glass sunroof lid

Labor Allowance: Refer to KSD

*Main Work: Use this labor operation number when this is the only repair being performed, or if this is the main repair when performed along with other repairs at the same time. If this is not the main repair, refer to KSD for the associated (+) labor operation code.