

---

# Table of Contents

## Lane Departure Warning

Subject	Page
Introduction .....	5
Display and Control Concept .....	6
Head-up Display (HUD) .....	8
Systems Overview .....	9
Functions .....	12
One Function, One Control Unit .....	12
Lane Detection .....	13
Roadway Markings .....	14
Road Situations .....	15
Environmental Conditions .....	18
Physical Limitations .....	20
Availability of the Lane Departure Warning .....	22
Warning Output .....	22
Warning Point .....	22
Warning Duration .....	23
Suppression of the Warning .....	23
System Components .....	24
Lane Departure Warning Control Unit .....	26
Installation Location .....	27
Overvoltage/Undervoltage Behavior .....	27
Wake-up .....	27
Sleep Mode .....	27
Lane Departure Warning Camera .....	28
Colored or Black Roadway Marking .....	28
Camera Size .....	30
Camera Objective .....	30
Vibration Motor .....	30
Windscreen .....	31
Button .....	31
Other Control Units .....	31
Steering Column Switch Cluster .....	31
Car Access System .....	31
Instrument Cluster/Head-up Display .....	31

---

Subject	Page
Body Gateway Module .....	.31
Other Components .....	.32
Mirror Caps, Cable Finisher, Headlining .....	.32
Mirror Base With High Beam Assistant .....	.32
Service Information .....	.33
Calibration .....	.33
Diagnosis .....	.35
Check Control Message .....	.35

---

BLANK  
PAGE

---

# Lane Departure Warning

Model: E60, E61

Production: From 3/2007 Production

Model: E63, E64

Production: From 9/2007 Production

# OBJECTIVES

After completion of this module you will be able to:

- Explain the operation of the Lane Departure Warning System
- Identify the Components used in the Lane Departure Warning System
- Understand the operation of the camera

# Introduction

The lane departure warning is available to order from 03/07 as option 5AD for the E60 and E61. The feature will be introduced in 09/07 on the E63 and E64.

Fatigue or inattentiveness on the road can cause a driver to unintentionally leave a lane. This could result in the vehicle driving into a lane with oncoming traffic or ditches at the side of the road.

BMW's lane departure warning is a driver assistance system designed to inform the driver in good time of unintentional course deviations by means of vibrations in the steering wheel intended to prompt the driver to make corrective steering movements.

The lane departure warning is a driver assistance system. The area in front of the vehicle is captured by a camera. This makes it possible for the roadway markings to the right and left of the current lane to be detected.

If the vehicle approaches a roadway marking in the absence of a turn indication, the driver is informed of the course deviation by steering wheel vibrations before the vehicle crosses the line.

The camera is fitted near the rear-view mirror behind the windscreen and its camera images to the control unit on a data line.

The control unit contains the software that determines the position of the vehicle in the lane from the camera images.

The lane departure warning is designed for operation on highways, major roads and well maintained country roads. A warning is issued if the system (current driving conditions within a specific time frame being equal) detects that the vehicle is crossing the roadside border line. The warning can be felt as a vibrating of the steering wheel.

The lane departure warning is switched on and off using a button on the steering wheel. When the ignition is switched on, the lane departure warning system always reverts to the state that was active when the vehicle was last switched off (last function mode).

The display indicating whether the lane departure warning is switched on or off is output by the instrument cluster or, optionally, by the head-up display. When the lane departure warning is switched on, there is an additional display indicating whether the system is primed or not.

Note: The system is only primed if it is switched on and has detected one or two roadside border lines with the vehicle travelling at a speed faster than 70 km/h.

## Display and Control Concept

The lane departure warning is switched on and off using the button shown below on the multi-function steering wheel. The lane departure warning is switched on and off with each press of the button.





When the ignition is switched on, the lane departure warning system always reverts to the state that was active when the vehicle was last switched off (last function mode).

Lane departure warning button E60/E61



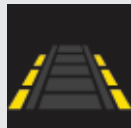

Index	Explanation	Index	Explanation
1	Lane departure warning button	2	Vibration motor

The system function display in the instrument cluster can take the form of the states listed in the following table.

<b>Displays in the instrument cluster</b>	
<b>Lane departure warning ON</b>	<b>Left-hand, right-hand lane or both lanes detected and <math>v &gt; 70</math> km/h</b>
	
<b>Display in the instrument cluster with ACC deactivated</b>	
	 Note: If the vehicle has Active Cruise Control ACC, the lane departure warning display is combined with the ACC symbol.
<b>Display in the instrument cluster with ACC activated</b>	
	 Note: When the ACC display is shown depends on the driving situation.

The display of the states listed above is the same for the head-up display.

<b>Displays in the head-up display</b>	
<b>Lane departure warning ON</b>	
	Shown here without the ACC symbol.
<b>Left-hand, right-hand lane detected or both lanes detected and <math>v &gt; 70</math> km/h</b>	
	Shown here with the ACC symbol.

Note: There is an option to switch the lane departure warning display in the head-up display on or off on the Central Information Display using the controller.

The lane departure warning can be switched on as of terminal 15 ON. The system is available from a speed of 70 km/h. The lane departure warning will also be primed if lanes are detected. If the lane departure warning is switched on at speeds of under 70 km/h, a message will appear in the instrument cluster for 3 seconds indicating availability above a speed of 70 km/h.



Message indicating the availability of the lane departure warning.

## Head-up Display (HUD)

It is possible to activate or deactivate the lane departure warning display in the Head-up Display using the controller.

The activation option is located in the Head-up Display menu > Head-up Display display options. Select "ACC/lane departure warning" and confirm with the controller.



HUD menu > Head-up Display display options E60



# Systems Overview

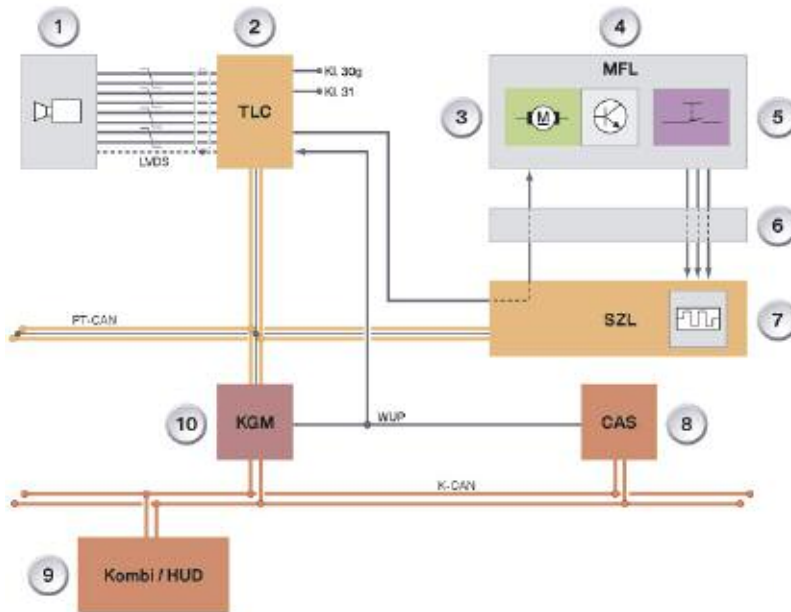

Index	Explanation	Index	Explanation
1	Lane departure warning camera	8	Car Access System
2	Lane departure warning control unit	9	Instrument cluster/head-up display
3	Vibration motor	10	Body gateway module
4	Multi-function steering wheel	K-CAN	Body CAN
5	Lane departure warning button	PT-CAN	Powertrain CAN
6	Volute spring cassette	W-UP	Wake-up
7	Steering column switch cluster		

Lane departure warning system overview The lane departure warning system receives a number of input signals. The image data of camera (1) is evaluated in lane departure warning control unit (2) together with the other vehicle data that the control unit receives on the PT-CAN. The lane departure warning is realized from the combination of this data.

Instrument cluster (9) and head-up display (9) output the displays of the lane departure warning.

Electric motor (3) in multi-function steering wheel (4) produces the vibration of the steering wheel by means of an imbalance mass.

Body gateway module (10) transfers the PT-CAN messages from the lane departure warning control unit to the K-CAN and vice versa.

System Schematic Circuit Diagram

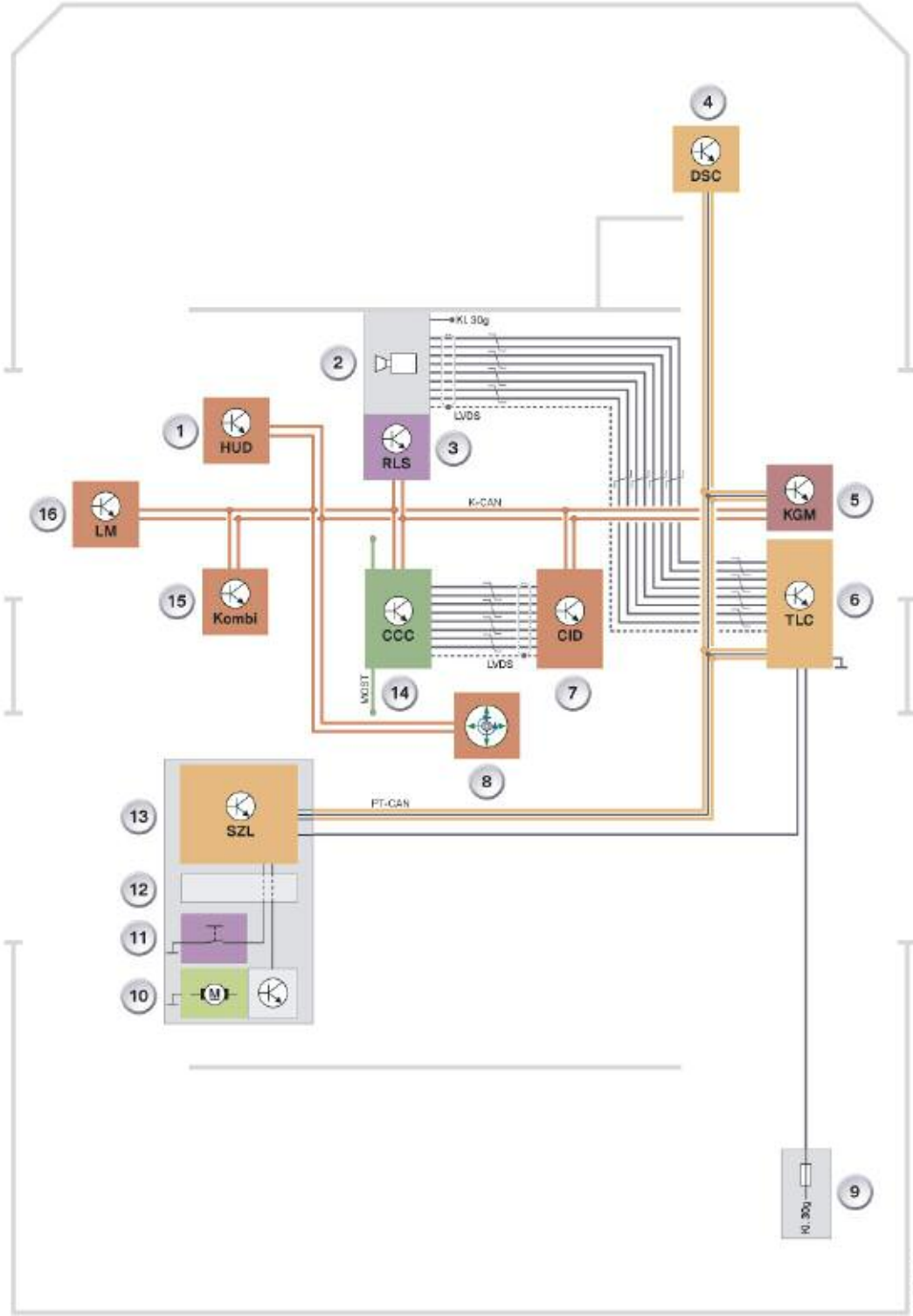

Index	Explanation	Index	Explanation
1	Head-up display HUD	12	Volute spring cassette
2	Lane departure warning camera	13	Steering column switch cluster SZL
3	Rain/light sensor RLS	14	Car Communication Computer CCC
4	Dynamic Stability Control (DSC)	15	Instrument cluster Kombi
5	Body gateway module	16	Light module LM
6	Lane departure warning control unit	K-CAN	Body CAN
7	Central Information Display CID	PT-CAN	Powertrain CAN
8	Controller	MOST	Media Oriented System Transport
9	Fuse in the rear distribution box	LVDS	Low Voltage Differential Signalling
10	Vibration motor	KL 30g	Terminal 30 switched
11	Lane departure warning button		

Camera (2) sends image data to lane departure warning control unit (6) on the LVDS data line.

The control unit receives vehicle data on the PT-CAN. The vehicle data includes the status of the turn signal steering column switch or the button for the lane departure warning, for example.

Instrument cluster (15) is able to display whether or not the lane departure warning system is switched on. The primed status or availability of the lane departure warning system is also displayed in the instrument cluster. Using controller (8), it is possible to select an option to have the information displayed in head-up display (1). The relevant menu appears in Central Information Display (7).

# Functions

## One Function, One Control Unit

The lane departure warning system receives a number of input signals.

Details of the input and output signals evaluated by the lane departure warning system are listed below.

### Input and output signals

Input signal	Sensor control unit	Explanation
Steering wheel angle	Dynamic Stability Control steering column switch cluster steering angle sensor	Lane detection assistance
Brake pressure	Dynamic stability control	Brake pressure threshold as warning cancellation criterion
Road speed	Dynamic stability control	Lane detection assistance
Road speed	Instrument cluster	Control of the primed status display
Terminal status	Car Access System	Control of the operating states of the lane departure warning control unit
Vehicle identification number	Car Access System	Detection as to whether the control unit fitted and the camera match the vehicle
Engine status	Digital Motor Electronics/ Digital Diesel Electronics	Activation of the processor for image processing after the engine start
Lane departure warning button	Steering column switch cluster	System switch on/off
Direction indicator	Steering column switch cluster	Suppression of warnings in case of intentional lane departure
Wiper status	Steering column switch cluster	Support of lane detection by detection of when the windscreen wiper sweeps through the camera image
Battery voltage	Instrument cluster	Fault code memory
Kilometre reading	Instrument cluster	Fault code memory
Output signal	Sensor control unit	Explanation
Lane departure warning	Instrument cluster Head-up display	Display of status and primed status in the instrument cluster and head-up display
Check control message	Lane departure warning control unit	Request of the Check Control message

---

## Lane Detection

The camera is fitted to the windscreen near the rear-view mirror. The camera captures the roadway up to approximately 40m to the front of the vehicle and up to approximately 5 m to the right and left.

Using image processing technology, the lane departure warning control unit looks for possible lane markings in the images captured by the camera.

The software in the control unit also checks which lane markings are delimiting the current lane in which the vehicle is driving.

From the detected lane markings, the lane departure warning is then calculated for the vehicle.

## Roadway Markings

The roadway markings in the image may differ greatly depending on the type of road, environmental conditions or country. The system is able to detect various types of roadway marking in a number of situations.

Type of Roadway Marking



Explanation

Broken Lines



Unbroken Lines



Double Lines



Bott's Dots



"Car Pool" Lanes

## Road Situations

The lane departure warning is able to handle various road situations.

### Type of Roadway Marking



### Explanation

Roads with only a Center Line (edge of road on left-hand side not detected)



Roads without Center Line



Highway Exit



Highway Access



Turn-off

Type of Roadway Marking



Explanation

Hatched Zones



Short Breaks in the Marking



---

NOTES

PAGE

Environmental Conditions

The lane departure warning functions under different environmental conditions.

Type of Roadway Marking

Explanation



Rain/wet Asphalt



Night



Low-Level Sun



Snow



Fog

Type of Roadway Marking



Explanation

Light Colored Asphalt



Dark Asphalt



Tar Seams on the Road



Oncoming Vehicles

## Physical Limitations

Systems functionality may be restricted under various road and environmental conditions due to physical limitations.

### Type of Roadway Marking



### Explanation

Construction Sites



On roads with worn, poorly visible or inadequately painted lane markings.



On roads with colored or black lane markings



On roads on which the lane markings are covered by water, dirt, snow or ice.



On roads with sharp bends.

Type of Roadway Marking



Explanation

On roads with no distinct lane markings



On roadways that are too narrow



If the vehicle comes too close to a vehicle in front that the camera is unable to see the lane markings within the detection range.



If the view of the camera is blocked by dirt, snow, ice or other obstructions on the windscreen.



In very poor weather conditions (rain, fog, snow, etc.)



If intense light shines into the camera from the front or fades out the lane markings.

## Availability of the Lane Departure Warning

The system is available when:

- No system fault is present.
- The lane departure warning system is calibrated correctly.
- The vehicle speed is above the activation threshold (see following table).
- At least one roadway marking has been detected by the system with sufficient certainty.
- The vehicle is not in a construction site area with several possible roadway markings.
- The vehicle is on a road with an average lane width of more than 2.5 m.

The speed threshold above which the lane departure warning can be available has been adapted to country-specific conditions. In the US the activation threshold is 45 mph and deactivation threshold is 42 mph.

## Warning Output

The lane departure warning function only outputs a warning to the driver if the system is switched on and available.

### Warning Point

The system outputs the warning to the driver if the driver approaches a detected roadway marking. To do so, the system calculates the anticipated time ( $t$ ) before the roadway marking is crossed. The warning is output in time before the vehicle crosses the marking.

Since warning situations may arise more frequently on narrow roads, the warning is output later by tendency on these kinds of road.

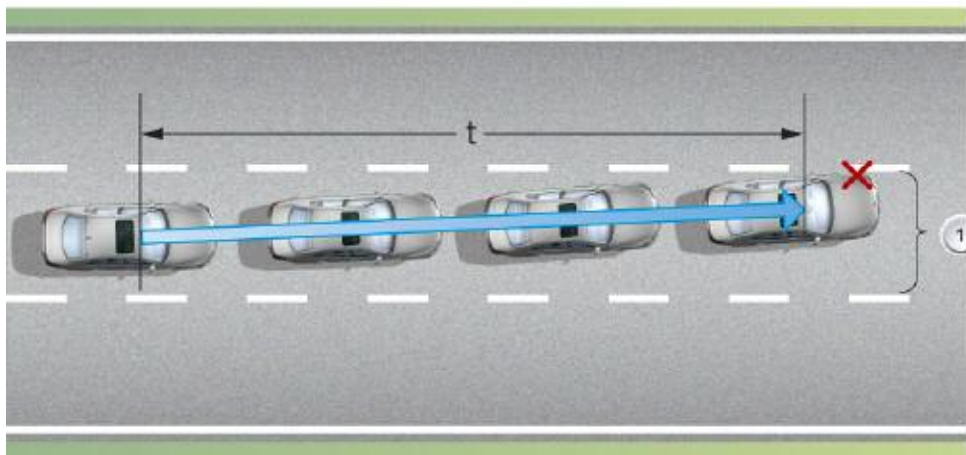

Warning output of the lane departure warning E60

Index	Explanation	Index	Explanation
1	Current Lane	$t$	Calculated time before point X

---

### ■ Warning Duration

The warning ends when:

- The driver steers back into the lane.
- A lane change is completed.
- The vehicle drives on the line for longer than 2.5 s.
- The turn signal is operated.
- The brake pedal is depressed with force (brake-pressure-dependent).

Note: A warning is output only once on approach to a roadway marking. The warning lasts no more than 2.5 s. If the vehicle remains on the line, no new warning will be issued. A new warning can only be issued if the vehicle has been steered back into the lane or the vehicle has completed a change of lane.

### ■ Suppression of the Warning

A warning is suppressed despite the display of primed status if the following conditions exist on one side:

- Turn signal operated before the vehicle is driven towards the warning trigger.
- One-touch turn signal indicated on the side from which a warning would be triggered.

There is no warning suppression if the hazard warning flashers are switched on.

# System Components

The most important components for the lane departure warning are:

- Lane departure warning control unit
- Lane departure warning camera
- Vibration motor in the multi-function steering wheel
- Windscreen
- Button
- Low Voltage Differential Signalling line
- Other control units
  - Steering column switch cluster SZL
  - Car Access System
  - Instrument cluster/head-up display
  - Body gateway module
- Other components
  - Mirror caps
  - Cable finisher
  - Headlining
  - Mirror base with high beam assistant



Component Overview (example of E61)

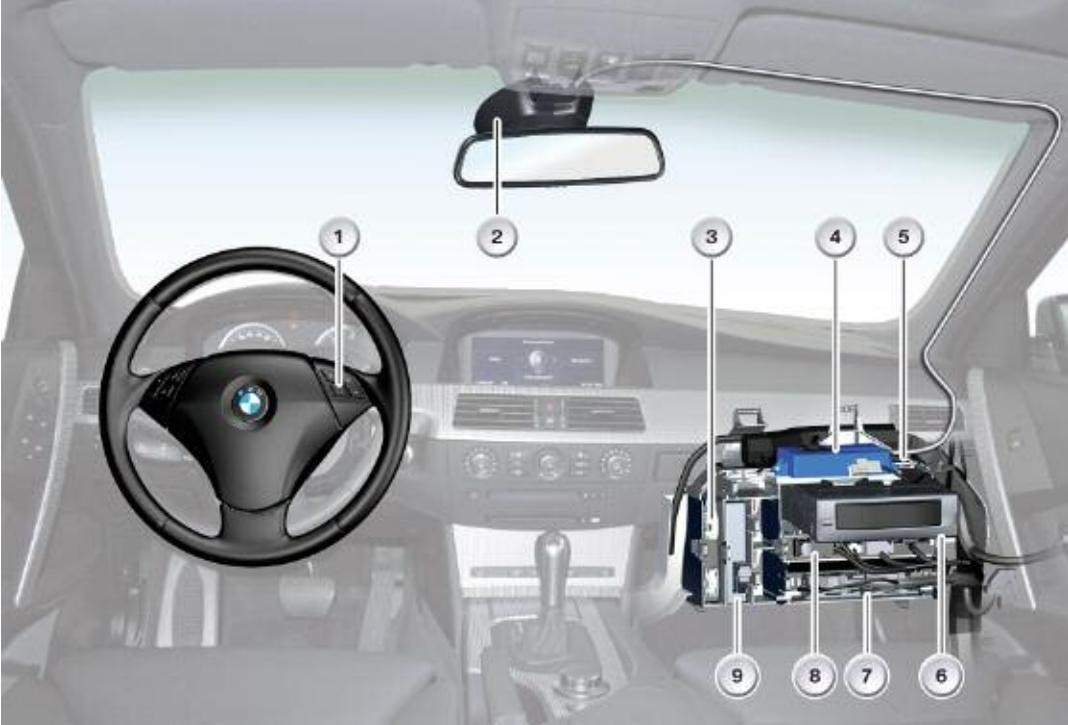

Index	Explanation
1	Lane departure warning button
2	Lane departure warning camera
3	Panorama glass sunroof control unit
4	Lane departure warning control unit
5	Control unit holder
6	CD changer
7	Body basic module
8	Body gateway module
9	Comfort Access

---

## Lane Departure Warning Control Unit

The control unit is accommodated in a 2/3 shell-type housing. For EMC reasons, the housing is made entirely of aluminum. It has two connectors:

- 12-pin connection to the vehicle electrical system
- 10-pin connection to the LVDS line.

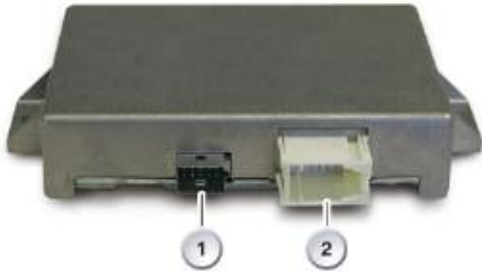

Index	Explanation
1	LVDS Connection
2	Vehicle Electrical System Connection

The control unit has two processors. One processor is for communicating with the vehicle electrical system on the PT-CAN. The second processor is used to calculate the lane departure warning.

The communication processor is activated as soon as terminal 30g is ON. Messages can now be sent and processed on the PT-CAN. The control unit itself is still in sleep mode.

From terminal 15 ON, the control unit reports to the vehicle electrical system on a cyclical basis. The control unit only becomes operational once the Engine running signal is present. This is because it is only at this point that the high-performance computer, whose responsibilities include image processing, is activated.

The high-performance computer evaluates the image data of the camera together with the other vehicle data that the control unit receives on the PT-CAN. The lane departure warning is realized from the combination of this data.

During operation of the wipe/wash system, the sweep of the wiper blades also takes them through the field of view of the lane departure warning's camera. For this reason, the control unit for the lane departure warning receives information about whether the wipe/wash system is switched on or off.

---

### Installation Location

The control unit is secured by a bracket to the support tube above the glove compartment.

### Overvoltage/Undervoltage Behavior

The voltage range in which the control unit operates is 9.0 V to 16.0 V.

### Wake-up

The control unit for the lane departure warning is woken by the wake-up signal of the control units on the PT-CAN.

### Sleep Mode

In sleep mode, the control unit is switched off.

## Lane Departure Warning Camera

The camera is fitted behind the windscreen at the base of the rear-view mirror. The camera for the lane departure warning captures the surrounding area, and therefore the lane markings, to the front of the vehicle.

The camera's scope of detection ranges from approximately 4 m to 40 m ahead of the vehicle. The camera has a horizontal aperture angle of approximately  $50^\circ$ , and a vertical aperture angle of approximately  $30^\circ$ .

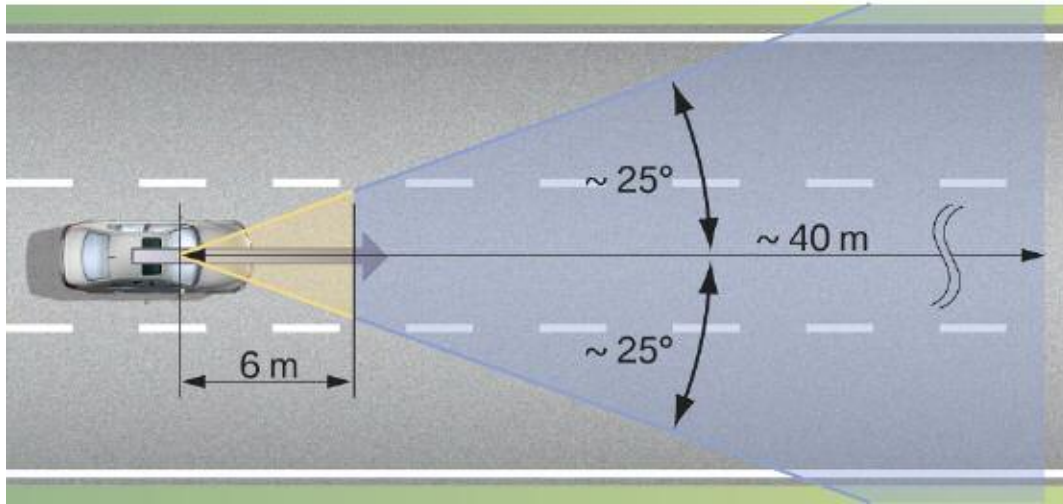

Detection range of the lane departure warning camera using the E60 as an example

The camera is a digital black/white CMOS camera. This means that the captured surroundings are output as a grayscale image.

### Colored or Black Roadway Marking

Roadway markings Colored yellow, blue, red or black are also represented in grayscale. The grayscale image may stand out poorly, or not at all, from the grey road surface.

In unfavorable situations, this could mean that these lanes cannot be detected.

Note: If no lane is detected, the lane departure warning does not display primed status.

Lane detection with the eye



Lane detection with the camera



### Camera Size

The graphic below illustrates the size of the camera by comparison with the vehicle's remote control.



Index	Explanation
1	Camera
2	Lens Shade
3	LVDS Connector

### Camera Objective

The camera objective has several glass lenses. They are coated to diminish or even fully eliminate scattered light and thereby increase the image quality of the camera.

### Vibration Motor

The vibration motor and its electronics are fully integrated inside the steering wheel. The vibration motor is fitted in the six o'clock spoke of the steering wheel.

To generate the vibration, there is a small imbalance mass on the shaft of the vibration motor. The vibration motor is controlled directly by the control unit. The electronics in the steering wheel are used to convert the control voltage supplied by the control unit into the voltage value required by the motor and to provide its stabilization. The control voltage corresponds to the on-board voltage.

The motor with imbalance mass issues a warning if the vehicle threatens to leave the current lane by causing the steering wheel to vibrate.



Index	Explanation
1	Vibration Motor
2	Imbalance mass
3	LVDS Connector

---

## Windscreen

The lane departure warning requires a windscreen matched to the system. The windscreen has a wider, black print that conceals the camera and a camera holder bonded on.

## Button

The SZL records the requests input at the button and sends them to the lane departure warning control unit on the PT-CAN.

## Other Control Units

### Steering Column Switch Cluster

The vibration motor in the steering wheel is connected directly to the lane departure warning control unit by the SZL and the slip ring.

All steering wheels equipped with steering wheel heating LHZ require an SZL with steering wheel heating. These SZLs are compatible with the lane departure warning.

For steering wheels without LHZ, there is a special variant of the steering column switch cluster for the lane departure warning.

### Car Access System

The CAS control unit controls the wake-up line and thus also the waking of the control unit for the lane departure warning.

### Instrument Cluster/Head-up Display

The instrument cluster and the head-up display display the activation status when the lane departure warning is switched on.



Note: The message indicating availability of the lane departure warning is only displayed in the instrument cluster.

A corresponding Check Control message is displayed in the event of a fault anywhere in the lane departure warning system.

### Body Gateway Module

The body gateway module transfers messages from the lane departure warning control unit (PT-CAN) to the K-CAN. The same applies in the opposite direction.

## Other Components

### Mirror Caps, Cable Finisher, Headlining

The lane departure warning system has wider mirror caps to conceal the camera, a cable finisher and a larger headlining cutout.

### Mirror Base With High Beam Assistant

When fitted in combination with the high beam assistant (FLA), the system has a special mirror base for package reasons.

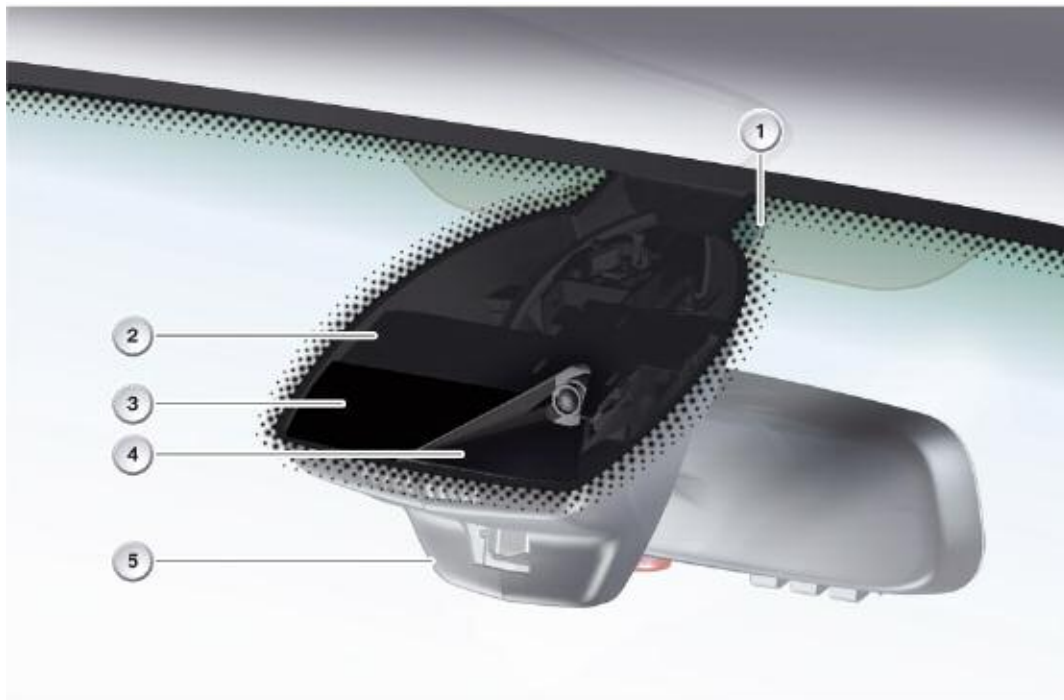

Index	Explanation
1	Headlining cutout with cable end
2	Rain/light sensor
3	Condensation sensor
4	Lane departure warning camera
5	Mirror caps/high beam assistant



## Service Information

### Calibration

If the system is to be able to calculate the distance to a given roadway marking, it must know the exact installation position of the camera on the one hand, and the camera's exact focal direction on the other.

Due to installation tolerances and tolerances inside the camera, the position of the camera's viewing angle may vary by several degrees.

The exact installation position of the camera and its installation angle are determined during calibration of the system and stored in the system.

In production, there is a dedicated calibration bench for this process that determines the measured variables by means of sample boards, which are arranged in a defined position relative to the vehicle.

Any replacement of the camera or windscreen requires a calibration of the system because the position of the camera and thus of the system sensor may have changed.

No calibration is required if the control unit is replaced. In this case, the calibration data stored in the camera is transferred to the control unit and stored there.

Each time the system is started, a check takes place to determine whether the system is calibrated and whether the system components are matched to each other and the vehicle. In this regard, the Vehicle Identification Number VIN stored in the control unit is compared with that of the vehicle's.

With this plausibility check, it can be determined whether the control unit is coded correctly and whether it belongs to the vehicle.

The VIN stored in the camera is then compared with the VIN stored in the control unit. If discrepancies are detected, the system detects that a camera requiring new calibration has been fitted and it outputs a corresponding fault code. For more details, please refer to the BMW diagnostic system or the repair instructions.

**Note:** A windscreen replacement cannot be detected by the system. In this case, the aftersales service organization is responsible for ensuring that the system is newly calibrated.

---

To have the system calibrated in the aftersales service organization, a diagnostics job is started. This diagnostics job investigates whether the camera is functional and has free line of sight. This is determined from the detection of movements in front of the camera. Free line of sight can be determined by having someone walk by in front of the camera, for example.

Calibration starts automatically on successful completion of this test step (good camera image). Calibration takes place during a calibration run, which can be carried out by the customer. In the event that the camera test failed, the calibration process is terminated and must be restarted after the possible interfering factors have been remedied.

A specially developed algorithm is used for calibrating the system during the calibration run. This algorithm scans the image for all straight edges and, from their orientation, determines the viewing angle of the camera.

The calibration algorithm works from a speed of 30 km/h. For evaluation purposes, it essentially uses images captured during straight-ahead travel. As soon as enough information has been recorded, the viewing angle is calculated and stored in the control unit.

This process generally takes a few minutes. In conditions of poor visibility, e.g. night, rain or winding roads, the calibration process may take up to 20 minutes.

The calibration run does not have to be completed during the first drive following the start of the diagnostics job. It is reset with each power cycle and restarted again until it has been successfully completed.

The system can be switched on and off during the calibration process. When the lane departure warning has been calibrated, the primed status display is shown when the lane departure warning is on. The conditions for this are:

- speed of over 70 km/h
- lane markings detected.

Following a replacement, e.g. of the control unit, the camera or the windscreen, it is necessary to recalibrate the lane departure warning.

The customer is notified by a Check Control message if the calibration process cannot be completed successfully after a net time of 7 minutes of straight-ahead travel at over 60 km/h.

The system then makes an automatic attempt to carry out calibration again. If this attempt under the conditions described above is unsuccessful, the system makes another attempt at calibration. A new Check Control message is only ever output after a power cycle following the first unsuccessful calibration attempt.

---

This process repeats itself until calibration has been successfully completed. If the calibration run does not complete successfully, the vehicle must be brought into the after-sales service organization. In the after-sales service organization, the calibration process can be terminated manually using a diagnostics job.

After the calibration process has been terminated, it must then be restarted once more.

## Diagnosis

The control unit for the lane departure warning is compatible with diagnostics. The fault code memory can be read using the BMW diagnostic system.

For test purposes, there is an option for controlling the vibration motor or the camera, for example. You will find more detailed information in the BMW diagnostic system.

## Check Control Message

Check control message	Description	Information in central information display
	Lane departure warning malfunction!	Lane departure warning malfunction! Please visit the nearest BMW Service.

The Check Control messages are output by the lane departure warning or the instrument cluster. If the control unit for the lane departure warning is faulty, it sends a request to have a Check Control message displayed.

If the signal from the lane departure warning drops out, the instrument cluster generates a Check Control message.

If a Check Control message is output, system availability is simply no longer displayed but the activation indication continues to be displayed in the instrument cluster or the head-up display, provided the system is activated.