

6-speed automatic transmission mechatronics module: E53, E60, E61, E63, E64, E65, E66, E83, E85, E87, E90, E91, E92

Installation location

The mechatronics module is a combination of hydraulic unit and electronics module. The mechatronics module is installed in the transmission oil pan.

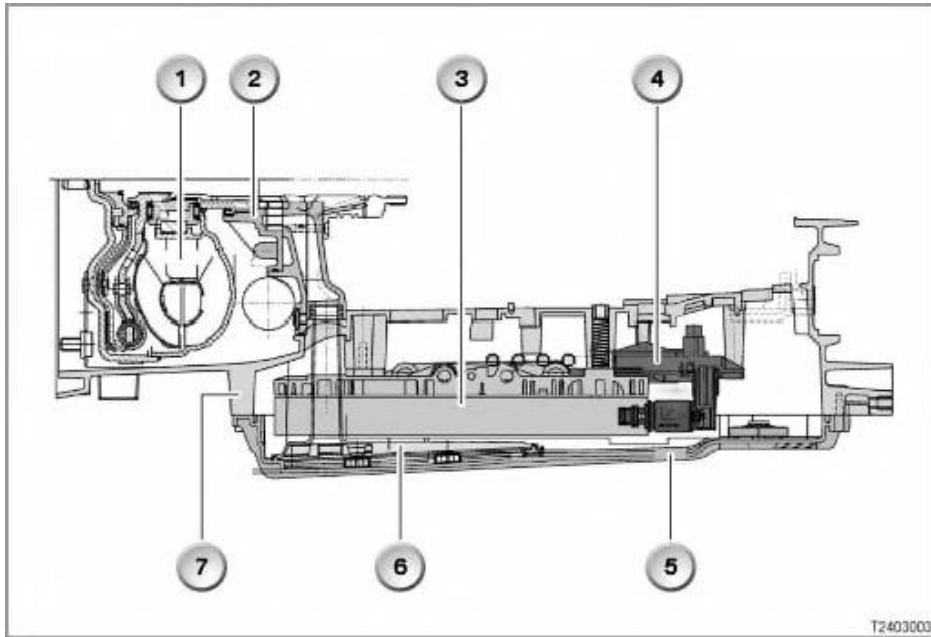

Item	Description	Item	Description
1	Torque converter	2	Oil pump
3	Hydraulic control unit	4	Electronics module
5	Transmission oil pan	6	Oil strainer with inlet pipe (integrated in transmission oil pan)
7	Transmission case		

Construction