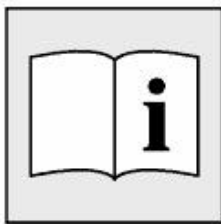
**Special tools required:**

- 34 1 080
- 34 6 320

*Necessary preliminary tasks:*

- Remove wheels.

Observe safety instructions on raising the vehicle.

If necessary, when replacing linings, reset CBS display in accordance with factory specification.

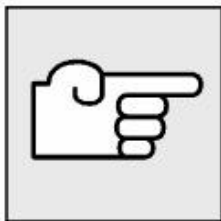
**Note:**

After completing work:

- Fully depress brake pedal several times so that brake linings contact brake disks.
- When installing new brake linings at front and rear axles, brake fluid level must be brought up to "MAX" marking.
- Hold ignition key for at least 30 seconds in position "1" without starting engine.

This clears a fault entry in the RAM

This prevents the brake wear indicator lamp from lighting up again.

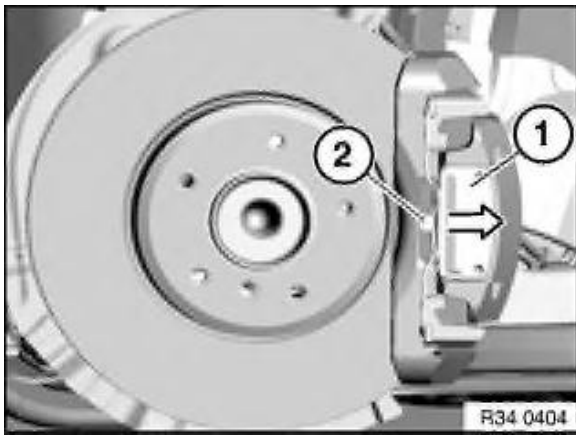

Lever out retaining spring (1) in direction of arrow towards rear.

Installation:

Attach retaining spring (1) first at top and bottom and then allow retaining lug (2) to engage in recess of brake caliper housing.

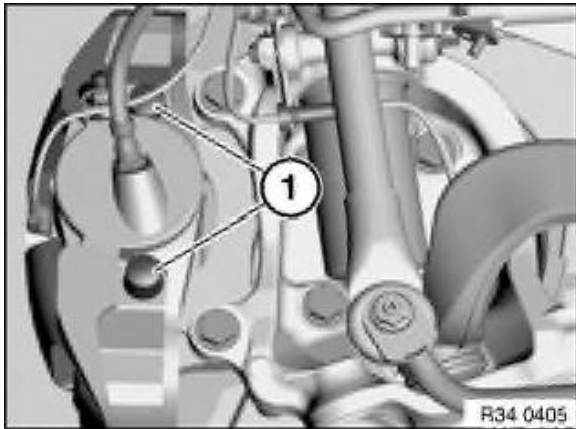

Remove plastic plugs (1).

Lift brake hose out of bracket.

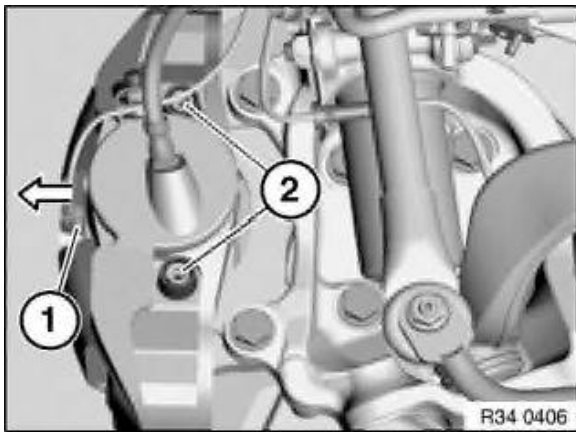

Left:

Pull brake lining wear sensor (1) towards rear out of lining.

If necessary, replace brake lining wear sensor.

Release guide screws (2) with special tool 34 1 080 .

Withdraw brake caliper backwards.

Installation:

Only clean guide screws; do not grease.

Check threads.

Replace all guide screws which are not in perfect condition.

Tightening torque 34 11 3AZ .

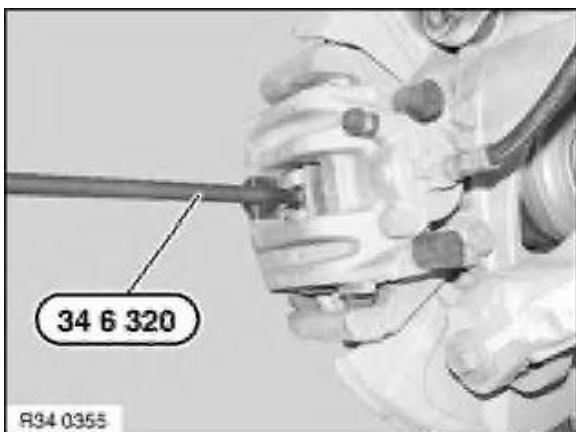

Press back brake linings and piston with special tool 34 6 320 .

Important!

When forcing piston back:

- Pay attention to brake fluid level in expansion tank; brake fluid that spills over will damage paintwork.

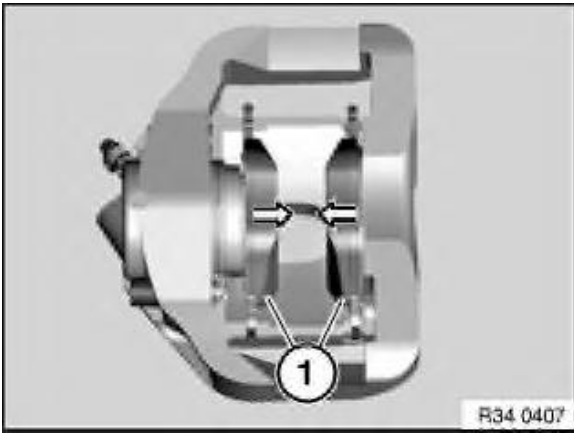

Press brake linings inwards and remove.

The two brake linings are seated with a spring in the piston or in the brake caliper housing and must not be mixed up.

Important!

Mark any worn brake linings.

In the event of one-sided brake lining wear, do not change brake linings round.

New brake linings may only be installed if the brake disk thickness is greater than or equal to the minimum brake disk thickness (MIN TH).

Observe minimum brake disk thickness of brake linings.

Clean brake linings.

Do not apply grease to brake pad backplate.

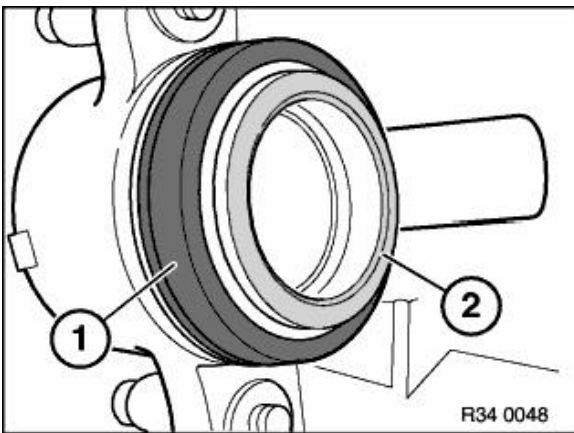

Check dust sleeve (1) for damage and replace if necessary.

Clean mounting face (2) of brake piston and apply a thin coating of anti-squeak compound.

Refer to BMW Service Operating Fluids.

Important!

Dust sleeve must not come into contact with anti-squeak compound as this may cause the dust sleeve to swell.

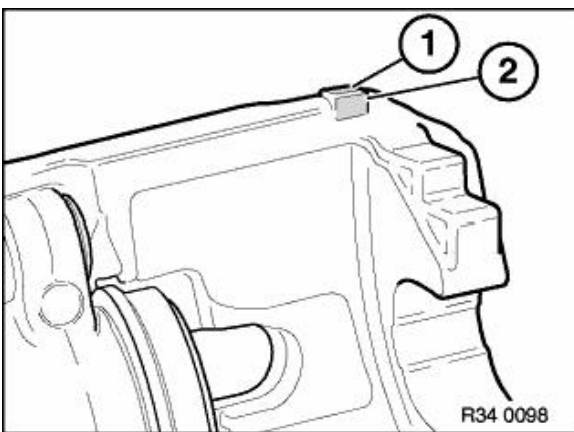

Clean mounting faces (1) and (2) of brake lining hammer heads/brake caliper housing and coat with anti-squeak compound.

Refer to BMW Service Operating Fluids.

Note:

Grease contact surfaces on brake caliper at top and bottom.

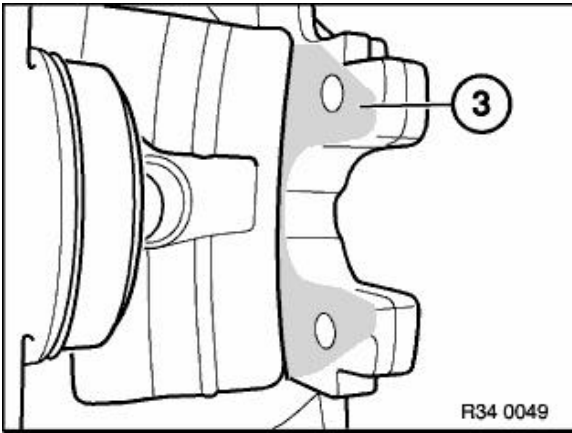

Clean mounting face (3) of brake caliper and apply a thin coating of anti-squeak compound.

Refer to BMW Service Operating Fluids.

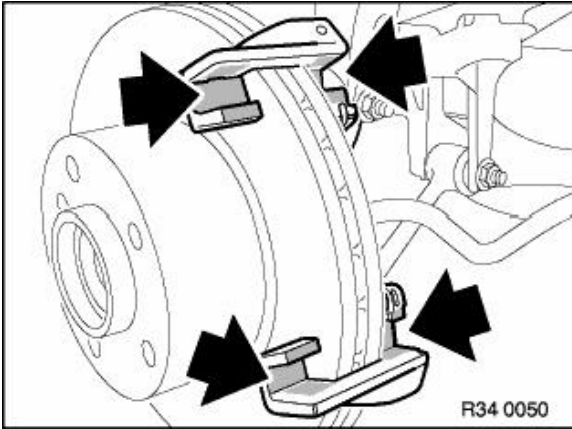

Clean brake caliper holder at hammerhead guides and apply a thin coating of anti-squeak compound.

Refer to BMW Service Operating Fluids.

34 1 080 Bit insert

Minimum set: Mechanical tools

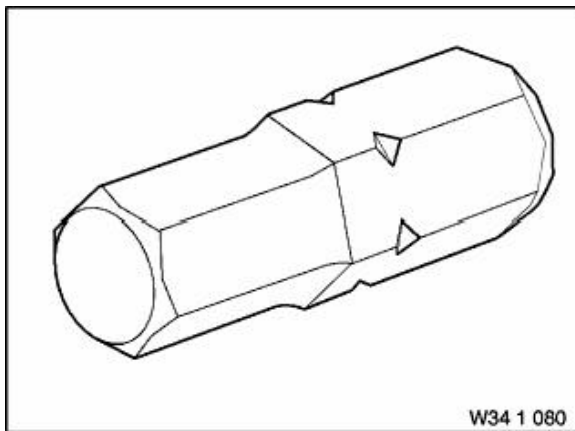

In conjunction with: Tool holder for 5/16" bit

Note: For loosening and tightening brake caliper bolts

Series: E31, E36, E38, E38/3, E39, E52, E53, E60, E61, E63, E64, E65, E66, E67

Storage location: B46

SI number: 1 15 99(483)

Order number: 34 1 080
Bit insert

34 6 320 Lever

Minimum set: Mechanical tools



Note: For compressing brake piston on front axle
Series: E38, E52, E60, E61, E63, E64, E65, E66, E67
SI number: 1 14 01(766)
Order number: 34 6 320
Lever

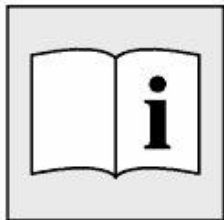

Necessary preliminary tasks:

- Remove wheel



Important!

If a brake lining sensor that has already been ground has to be replaced even though the minimum brake lining thickness has not yet been reached, you must observe the following: The new sliding contact must be filed down with a file to the same length as the ground sliding contact.

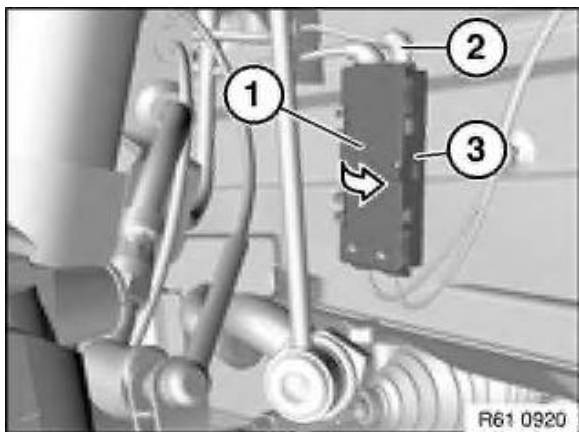

Open cover (1) on plug housing (3).

Unclip lead of brake lining sensor (2) from plug housing (3).

Disconnect associated plug connection of lead from brake lining sensor (2).

Feed lead from brake lining sensor (2) out of fixtures.

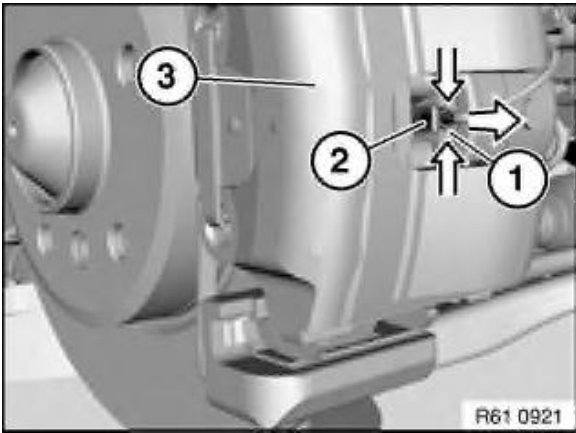

Press clip (1) together and detach brake lining sensor (2) in direction of arrow from brake caliper (3).

Installation:

Make sure clip (1) and brake lining sensor (2) are correctly seated in brake caliper (3).

34 11 Front Brake

	Type	Thread	Tightening specification	Measure
1AZ Brake disk to wheel hub (contact faces between brake disk and wheel hub cleaned and grease-free)	All			16 Nm
2AZ Brake caliper to steering knuckle (screws lightly oiled, contact surfaces between brake caliper and steering knuckle cleaned and grease-free)	E34, E36, E32, E31, E38, E39, E46, E52, E53, E30 / 325ix, E65, E66, E67, E83, E85, E60, E63, E64			110 Nm
2AZ with aluminum brake caliper	E31			115 Nm
	E12, E21, E23, E24 to 5.82			95 Nm
	E28, E30, E24, from 5.82			123 Nm
3AZ Guide bolt	All	wrench size 7 mm		30 - 5 Nm
4AZ Bolts to guidepin (always replace)	E30			35 Nm
5AZ Protective plate to steering knuckle	E85, E83	M6		9 Nm
	E67, E60, E63, E64, E65, E66	M6		12 Nm

34 11 Front Brake E60

Different thicknesses on brake linings	max. mm	0.01
Surface roughness of braking surfaces (precision-turned)	Ra μ	0.5 ... 3.5
Brake disc diameter Models: 520i 525i	mm	310
Brake disc diameter Models: 530i 530d	mm	324
Brake disc diameter Models: 545i 645Ci	mm	348
Wear warning from residual lining thickness	mm	3.0
Brake disk minimum thickness (MIN TH) stamped on brake disk body Models: 520i 525i	mm	22.4
Brake disk minimum thickness (MIN TH) stamped on brake disk body Models: 530i 530d	mm	28.4
Brake disk minimum thickness (MIN TH) stamped on brake disk body Models:545i 645Ci	mm	28.4
Max. machining limit per friction ring side (M models must not be machined!)	mm	0.8

6.0 Anti-squeak paste

Stops disc brakes from squeaking.

For usage, see repair instructions, Group 34

E12/E21/E23/E24/E28/E30/E31*/E32/E36/Z1/Z3/E53/E52/E65 front and rear axle

*) E31 front axle with Brembo fixed aluminium caliper no lubrication

<u>Trade name</u>	<u>BMW part number</u>	<u>Container size</u>
Plastilube	81 22 9 407 103	4 ccm pad, 100 pcs.

E38*/E39/E46 front and rear axle

*E38 front axle with Brembo aluminium fixed caliper no lubrication

<u>Trade name</u>	<u>BMW part number</u>	<u>Container size</u>
Never Seez Compound	83 23 9 407 830	100 g tube

Note:

Lubrication instructions in the repair instructions and on the information sheet supplied with the set of brake pads must be observed.