

E60 - US car phone system overview

This system overview includes the following overviews for the US version:

- Input/output for US car phone
- System circuit diagram for US car phone

- Input/output for US car phone

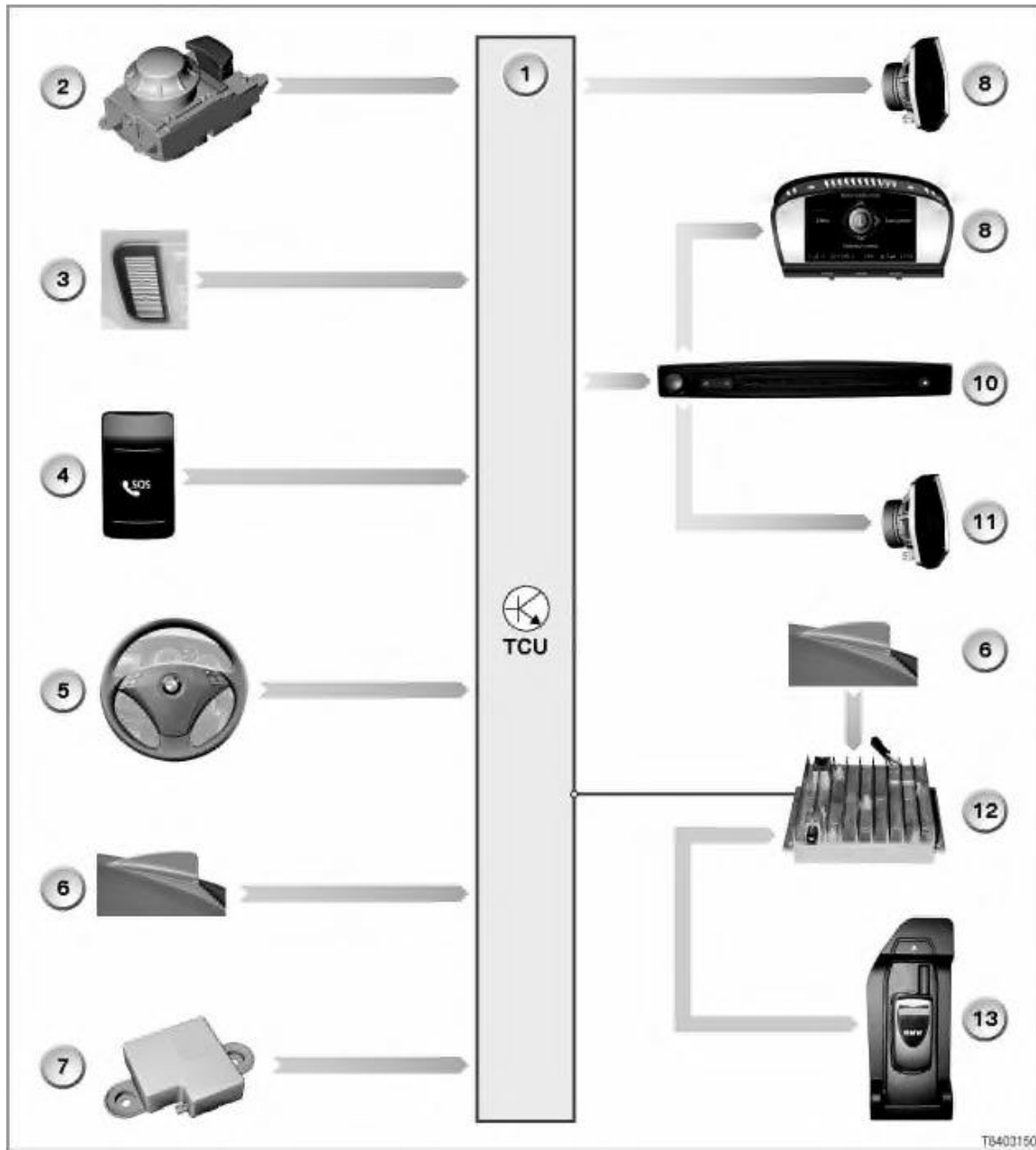

Key	Explanation	Key	Explanation
1	Telematic Control Unit (TCU)	2	Controller
3	Hands-free microphone	4	Emergency call button
5	Multi-function steering wheel (MFL)	6	SDARS aerial or telephone and GPS aerial
7	Emergency aerial	8	Emergency loudspeaker

9	Central Information Display (CID)	10	Multi-audio system controller (M-ASK)
11	Loudspeaker for audio mode	12	Compensator (special customer wish)
13	Eject box with Motorola Phoenix V60i mobile phone		

- System circuit diagram for US car phone

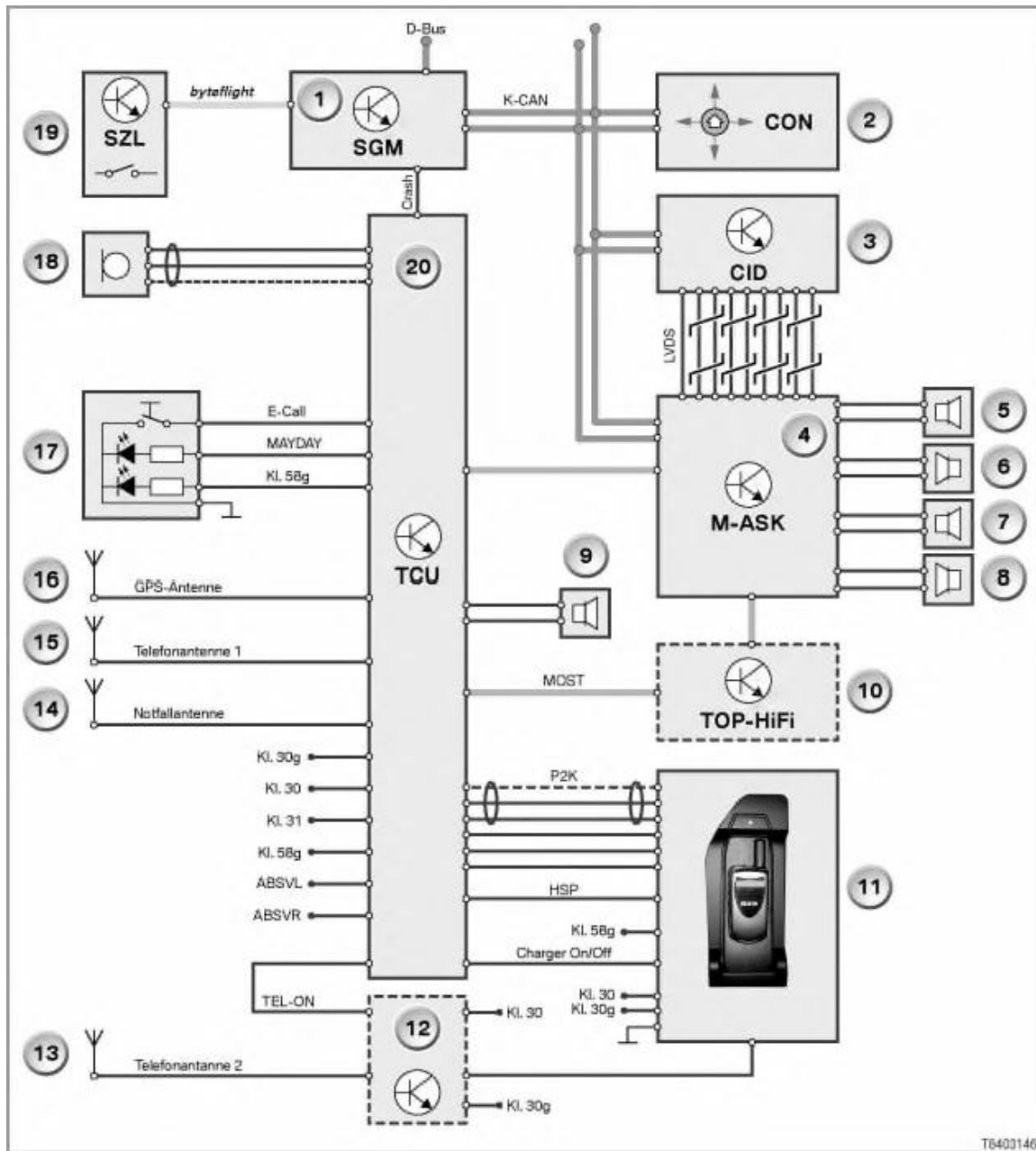

Key	Explanation	Key	Explanation
1	Safety and gateway module (SGM)	2	Controller
3	Central Information Display (CID)	4	Multi-audio system controller (M-ASK)
5	Front left loudspeaker (only if no Top-HiFi amplifier is fitted)	6	Rear left loudspeaker (only if no Top-HiFi amplifier is fitted)
7	Front right loudspeaker (only if no Top-HiFi amplifier is fitted)	8	Rear right loudspeaker (only if no Top-HiFi amplifier is fitted)

9	Emergency loudspeaker	10	Top-HiFi amplifier (option 677 "HiFi System Professional with Logic 7 signal processing")
11	Eject box with Motorola Phoenix V60 mobile phone	12	Compensator (special customer wish)
13	Telephone aerial 2	14	Emergency aerial
15	Telephone aerial 1	16	GPS aerial
17	Emergency call button	18	Hands-free microphone
19	Steering column switch cluster SZL	20	Telematic Control Unit (TCU)
ABSVL	Wheel speed sensor, front left	ABSVR	Wheel speed sensor, front right
AMPS	American Mobile Phone Standard	bytfight	Fibre-optic cable for especially fast data transmission
Charger On/Off	Signal to switch battery charger in eject box on/off during run-on period	CDMA	Code Division Multiplex Algorithm
Crash	Signal for automatic emergency call	D-Bus	Diagnosis bus
E-Call	Signal for manual emergency call	HSP	Signal "Motorola Phoenix V60 mobile phone locked in eject box"
Kl. 30	Terminal 30, power supply	Kl. 30g	Terminal 30g, aux battery
Kl. 31	Terminal 31, earth	Kl. 58g	Instrument lighting
K-CAN	Body CAN	LVDS	Low Voltage Differential Signalling
MAY-DAY	Voice recognition after crash message (LED flashes)	MOST	Media Oriented System Transport
P2K	Data connection or low-frequency signals	TEL_ON	Switch-on signal for compensator