



Installation Instructions

Page 1 of 2

July 2009

Audio, Sirius Antenna Connector

Ver 1.0

Accessory
Development

SUBJECT

Antenna Connector Kit - P/N 65 12 0 037 903

MODEL

3 Series (E90/91):	Vehicle Production SOP– 02/06
5 Series (E60/61):	Vehicle Production SOP– 02/06
6 Series (E63/64):	Vehicle Production SOP– 02/06
7 Series (E65/66):	Vehicle Production SOP– 08/06

These instructions supplement vehicle specific Sirius installation instructions.

The instructions below are developed for BMW vehicles and are not to be compared to any other existing instructions for vehicles other than BMW. No methods other than those specified in this document are to be used for installation in BMW vehicles. Left and right are determined from the driver's seat.

Carefully read all instructions and supplements before proceeding with the installation. Reference should be made to TIS for instructions dealing with a stock part of the vehicle but not stated in detail in these instructions.

The instructions were complete and up to date at time of publication; however, changes to the vehicle or installation may have occurred. Please report any problems or changes noted with the installation to BMW Technical Hotline, along with VIN, date of manufacture and as much detail as possible.

★ ★ DO IT RIGHT THE FIRST TIME, ON TIME, EVERY TIME ★ ★

PARTS INFORMATION**Contents of Antenna Connector Kit – P/N 65 12 0 037 903**

Description	Qty	BMW Part Number
Fakra Connector-new style	1	NA
Fakra Connector-old style	1	N/A

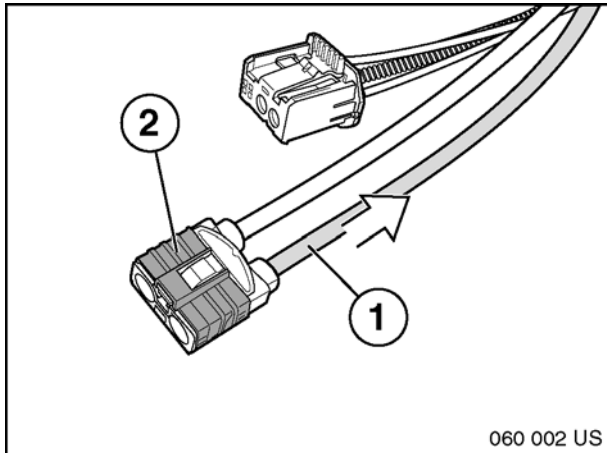
INSTALLATION

1. Locate satellite radio (SDARS) antenna connector cable (1) marked as Pin 1 on gray connector (2).
2. Release locking tab (2) on connector and remove satellite cable (1) from connector by pulling away from the connector as indicated.

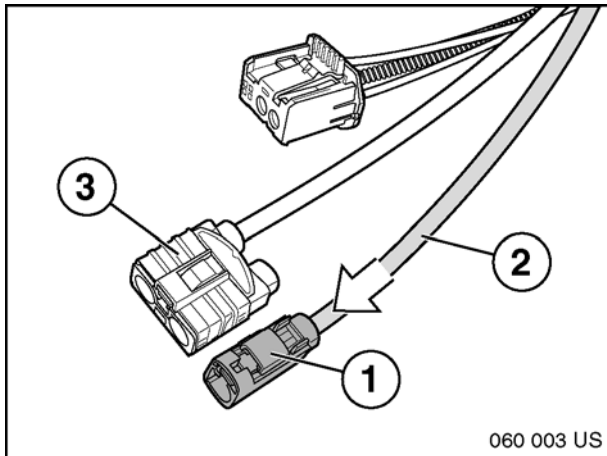

3. Insert satellite cable connector (2) into appropriate Fakra housing (1) from Antenna Connector Kit. A click should be heard once the antenna is fully seated. Press down on locking tab (1) to secure the connection.

Note: Style of Fakra housing needed will be determined by vehicle production date.

4. Tie back original 2 pol connector with terrestrial cable (3) as it will not be used.

Connector Installation Complete.

Proceed with, vehicle specific installation instructions available on ASAP.